

Priority Manufacturing Prospector PE1200

*INFORMATION
&
OPERATING
INSTRUCTIONS*

**READ AND UNDERSTAND THESE INSTRUCTIONS
BEFORE OPERATING THE MACHINE**

Manufactured Expressly for

Jon-Don

400 Medinah Road
Roselle, IL 60172
800-556-6366 • JONDON.COM

Contents:

Machine Specifications	2	Care & Maintenance	4
Record Important Information	2	Views of Machine	5
Safety Information & Cautions	3	Set Up & Operating Instructions	6
Your New Machine	4	Warranty	7
System Features	4	Troubleshooting	8
Chemicals	4	Parts List	9
Tools & Accessories	4	Exploded View	10

Machine Specifications:

	Prospector PE1200 120V
Pump	400-1200 psi, adjustable, piston pump
Vacuum	Dual 3-stage, 180" lift, 107 cfm
Auto Dump/Auto Fill	20GPM Auto dump Discharge through ¾ hose
Power	15 -19 Amp
Tank Capacity	15 gal, solution and recovery
Vacuum Shut-off	Ball Float
Dimensions	36-3/4" H 23-1/2" W 32" L
Weight	133 lbs
Warranty	See Below

Machine and Purchase Specifications:

RECORD AND RETAIN THIS IMPORTANT INFORMATION

Prospector 1200

Serial Number: _____

Purchase Date: _____

Write purchase location and phone number:

And don't forget to register your purchase to activate your warranty

CRITICAL SAFETY INFORMATION & CAUTIONS

The acceptable use of this machine is for commercial/professional cleaning, for example, in hotels, schools, hospitals, and offices, rather than for personal housekeeping.

NOTE: Read all instructions before using this machine. Improper use or misuse of the machine can result in personal injury or property damage.



To reduce the risk of personal injury or property damage, follow these procedures:

- Connect to a properly grounded outlet only.
- Do not operate the machine in an explosive environment.
- Do NOT use Solvents.
- Never add water over 120°F/ 49°C to the solution tank.
- Do not pick up anything that is burning or smoking, such as cigarette, matches or hot ashes, or any health endangering dusts. Do not use to pick up flammable or combustible liquids such as gasoline or use in areas where they may be present.
- To avoid electric shock, do not expose to rain or snow and keep from extremes in temperature. Store in a heated location. Use the machine indoors. Do not use outdoors.
- Do not use this machine to dry vacuum before wet cleaning.
- Do not use with damaged cord or plug. If the machine is not working as it should, has been dropped, damaged, left outdoors or flooded with water, return it to a service center.
- Do not leave the machine unattended when it is plugged in. Unplug the unit from the outlet when not in use and before servicing.
- Use only as described in this manual. Use only the manufacturers recommended attachments.
- Do not handle the plug, the cord, or the machine with wet hands.
- Extension cords must be 12/3 and no longer than 50 feet. Replace the cord or plug immediately if the ground prong becomes damaged.
- Do not put any object into opening. Do not use with any opening blocked; keep free of dust, lint, hair, and anything that may reduce air flow.
- Keep loose clothing, hair, fingers and all parts of body away from openings and moving parts.
- Liquid ejected at the spray nozzle could be dangerous as a result of its temperature, pressure, or chemical content.

READ AND SAVE THESE INSTRUCTIONS

YOUR NEW MACHINE:

When you receive your new machine, examine the packaging for signs of shipping damage. Carefully unpack the machine and inspect it. If you see evidence of damage to the container or the contents, contact the freight carrier immediately.

Additionally, ensure all parts and accessories are present; if you notice anything missing, contact your distributor without delay.

SYSTEM FEATURES:

VACUUM: The vacuum motors provides an excellent ratio of water lift to air movement (see specs, page2). Surface should dry quickly if not over-wetting while cleaning.

PUMP: The pump is a piston style, positive displacement pump. The AC motor runs continuously when turned on, the use of the pressure regulator enables the operator to set the pressure to the desired PSI, between 400 and 1200

DUMP PUMP: The dump pump is a 20 GPM sump style pump. When you want to use the auto dump feature, just connect a garden hose to the auto pump outlet and turn on the dump pump (see switch plate descriptions).

AUTO FILL: connect a hose from a utility or janitors sink and turn on the water. When the solution tank is full, an internal valve will prevent the tank from over-filling.

CHEMICALS:

The use of clear water in the machine is recommended, within the application of properly diluted cleaner as a pre-spray on the area to be cleaned; however, you may mix water and cleaning chemicals in a bucket -- according to directions on the chemical label -- and then pour into the solution tank. If you chose to use chemicals in the machine, always use a cleaner with a pH as close to neutral as possible to avoid premature wear of the pump, seals, and/or other components.

Damage caused by the use of strong chemicals is not covered by the warranty.

The use of powder chemicals is discouraged; unless they are mixed very thoroughly and rinsed out completely at the end of the job, powdered cleaners could cause a build-up in the pump, lines, heater and/or quick disconnect. Any problem caused by a chemical build-up is not covered by warranty.

If foaming occurs as you clean, use a defoamer, either in the recovery tank or on the area being cleaned, to prevent overflow which can cause water damage to machine components.

TOOLS & ACCESSORIES:

Use only manufacturer's recommended tools and accessories. If the spray valve on your cleaning tool begins to leak or if the spray tips get worn and are no longer providing a nice even spray pattern, order replacements from your distributor.

CARE AND MAINTENANCE:

For continual peak operation, clean the internal plumbing by rinsing with clear water at the end of each job. About once a month, rinse the machine with a commercial flushing compound to break-up any mineral or chemical accumulation that may have formed from the use of hard water or chemicals.

The vacuum motors and the pump do not require any scheduled maintenance; however, the vacuum motor may require replacement brushes after 750-1000 hours.

To help maintain a professional image; clean the exterior of the machine with an all purpose detergent, and protect it with automobile interior polish. Lubricate the wheels, castors, and quick disconnects with an all purpose, silicone spray.

VIEWS OF THE MACHINE:

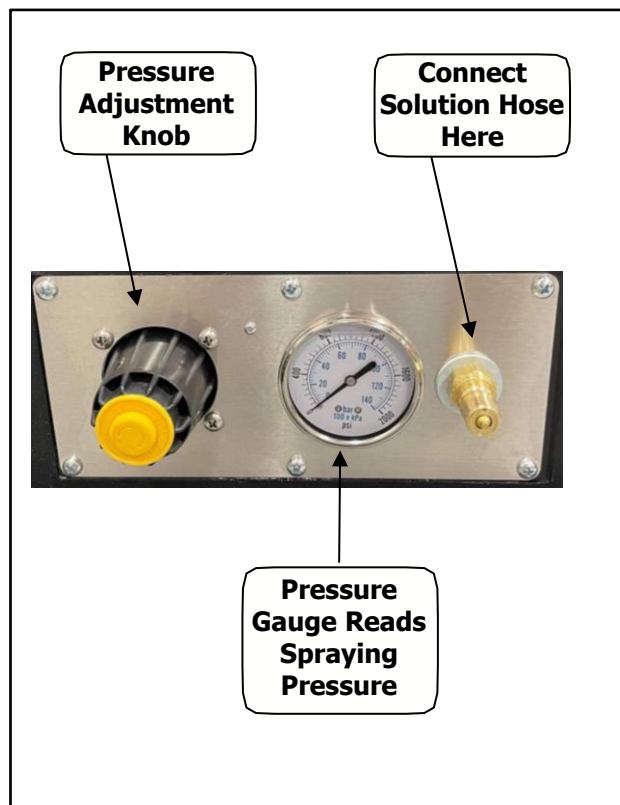

SET-UP AND OPERATION:

1. Before each use, inspect the machine, hoses, and cleaning tool for cleanliness and completeness, Ensure the spray nozzles on the cleaning tool are tight and that the ball float in the recovery tank is clean and operational.
 2. Close the clear, screw-on lid on the recovery tank, and screw the cap onto the drain hose.
 3. Turn off all the switches.
 4. Plug the power cords into properly grounded outlets. Do not connect both cords to the same outlet. Green indicator light will illuminate when on separate power circuits.
 5. Fill the holding tank with clear water. NOTE: If you choose to take advantage of the Auto Dump and/or Auto Fill features on this machine, follow steps 5A through 5E, otherwise got to Step 6.
 - 5A. Auto Dump – simply connect garden hose on the Auto Dump garden hose to the auto dump connector located on the upper right corner of the recovery tank.

5B. Attach a garden hose to the Auto Dump fitting. Place the open end of the garden hose into a drain or toilet.

5C. Turn on the Auto Dump Pump switch when you begin cleaning, and the auto dump pump will turn on when the recovery tank is nearly full and pump out the recovered water. The pump will automatically turn off when the tank has emptied.

5D. Auto Fill - Connect the water source to the stainless steel auto fill hose on the front of the holding tank on the front of the machine.

5E. Turn on the water at the source. The solution tank will fill with water and when it reaches capacity, a valve will shut off the water flow. Once the water in the solution tank has fallen, as you clean, the auto fill valve will allow the water to begin flowing into the tank again.
 6. Connect the solution hose and the vacuum hose to the machine and to the cleaning tool.
 7. Turn on the pump and spray through the tool for a few seconds to fill the lines with water.
 8. Pre-spray the area to be cleaned with the detergent of your choice.
- NOTE: If you choose to add a detergent to the solution tank, be sure to mix well, and always follow the use & dilution instructions on the chemical label. Use a chemical with a pH between 5 and 10 to reduce the likelihood of premature wear to the pump and other seals.
9. Spray through your cleaning tool as you adjust the pressure regulator knob, on the front of the machine, to achieve the desired spraying pressure.
 10. Turn on the vacuum motors.
 11. Begin cleaning, following industry accepted practices.
- NOTE: Use defoamer any time foaming occurs in the recovery tank to prevent damage to the motor or other components.
- NOTE: Foam will not lift the ball float.
12. When finished with the job, remove any unused solution from the solution tank, and run a few gallons of clean water through the system. Drain the recovery tank by opening the drain hose over a drain or a bucket. Release any residual pressure from the cleaning tool before disconnecting the hoses from the cleaning tool.

TROUBLESHOOTING



**ALWAYS UNPLUG THE MACHINE BEFORE
DISCONNECTING OR CONNECTING ANY WIRES OR
COMPONENTS**

SYMPTOM	POSSIBLE CAUSE
Low pressure	Plugged or dirty inlet filter; Pump is leaking Pump valve(s) damaged; Pressure regulator valve is worn and leaking water back into the holding tank even while spraying from the tool;
No spray	Solution tank is empty; Quick couplings on solution line are not completely connected to machine or tool; Spray tip(s) plugged; Pump motor is not running Plugged/dirty pump inlet filter; Plugged or damaged solution hose or quick disconnect
Pump not running	No power to pump -- no power to cord On/off switch is bad; Pump motor is getting power but won't run – check motor brushes;
Low suction	Recovery tank lid not sealed; Dirty vacuum inlet screen; Vac hose loose or cracked; Vacuum gasket is damaged or compressed
No suction	Recovery tank is full; Vacuum is not running – bad switch or bad vacuum

Always use original equipment replacement parts.

Contact your distributor for additional information or to arrange for service.

Priority Manufacturing Prospector PE1200

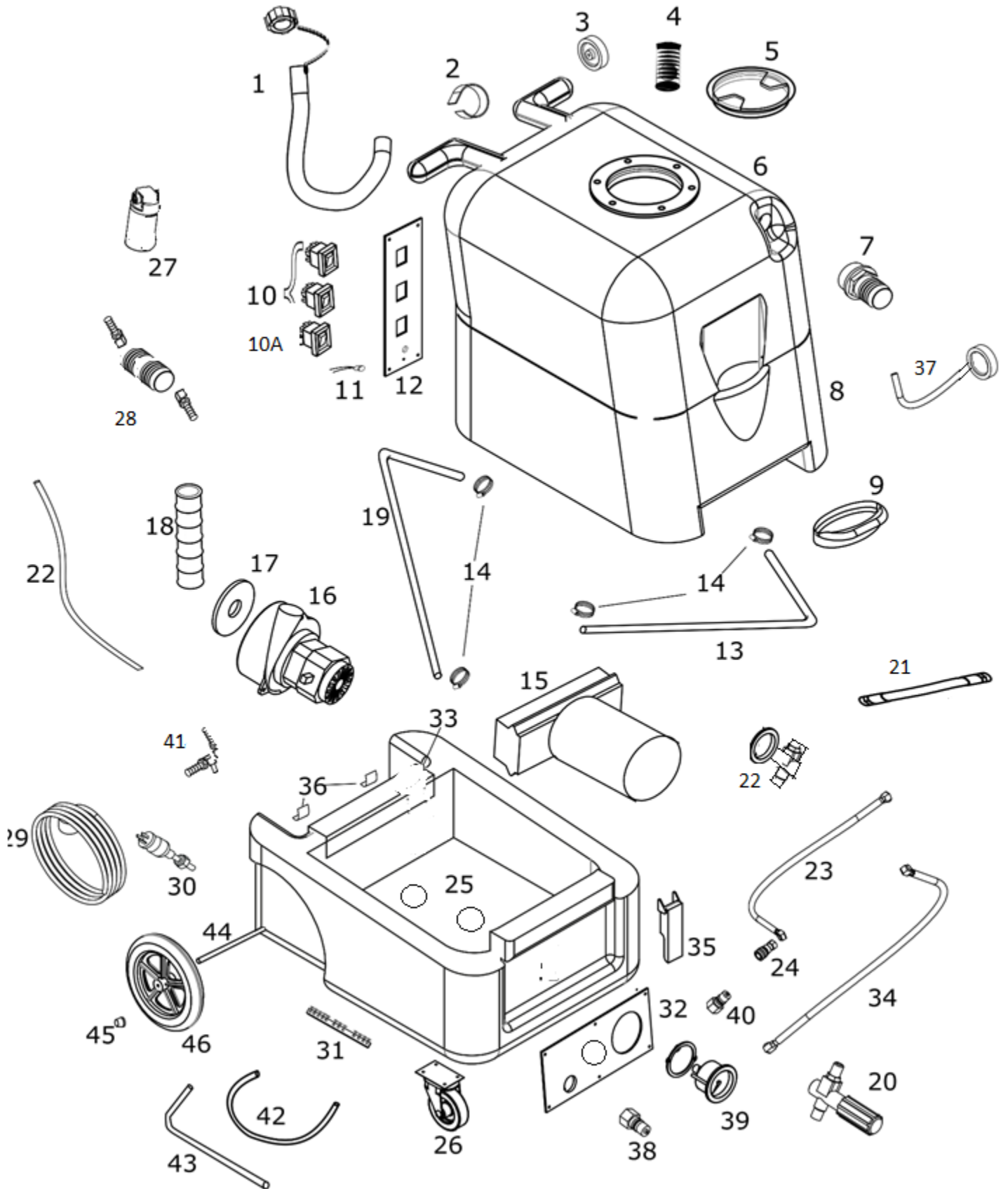

Prospector PE1200 WARRANTY

This limited warranty begins on the date of the customers purchase and is valid and available to the original purchaser only.

10-YEAR LIMITED HOUSING WARRANTY

Manufacture warrants that all rotationally molded housing and tanks will be free from manufacturing defects, defects in workmanship, and defects in material for Ten (10) years from the date of original purchase, for the original purchaser only. This warranty does not apply and is void if there is evidence of improper use, altered, abuse or neglect. **Replacement cost does not include the cost of parts, shipping or labor.**

2-YEAR MAJOR COMPONENTS WARRANTY

Manufacturer warrants that, pumps, heaters and vacuum motors, are covered under a two (2) year limited warranty from the date of original purchase. This warranty does not apply and is void if the pump, vacuum motor, or heater has worn motor brushes, water damage, freezing, chemical build-up, chemical damage, or evidence of abuse, neglect or tampering. **This warranty covers the cost of the replacement parts, shipping of the new part and labor.** Manufacturer will ship parts via normal ground delivery prior to the return of the defective parts at normal charge to the Distributor. Extra charges for expedited or air shipments will be bill to the Distributor. Manufacturer will credit the Distributor for the replacement parts, if the defective parts are returned within 30 days and are determined to be covered under warranty. **This warranty does NOT cover the cost of shipping the damaged parts back to Manufacturer for evaluation.** If a component is replaced, Manufacturer will offer a new 90-day limited warranty on the new component.

90-DAY WEAR PARTS LIMITED WARRANTY

Manufacturer will replace all wear parts for 90 days from the date of original purchase of new equipment. Wear parts are items which wear out as a result of usage or the passage of time and are consumed despite attempts to maintain them, such as gaskets, wheels, brass, cords, wires, electrical terminals, hoses, switches, thermostats, plastisol parts, filters, bearings, brushes, solenoids, O-rings, bulbs, castors, or other parts deemed wear items is manufactures sole discretion. **This warranty covers the cost of replacement parts, Labor and shipping**

Proof of purchase required