

REPAIR PARTS LIST

SANITAIRE

COMMERCIAL UPRIGHT

MODEL SC886-E

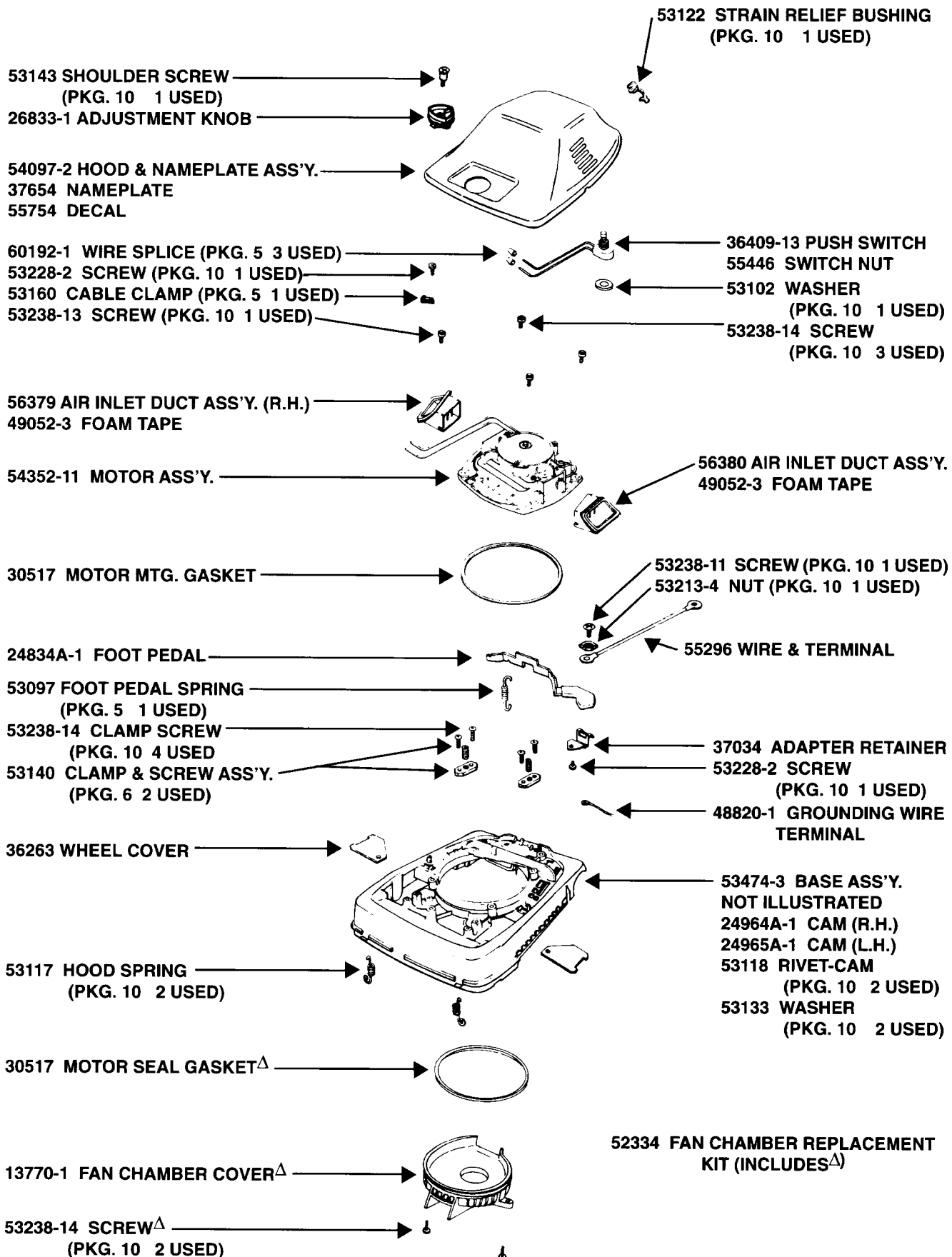

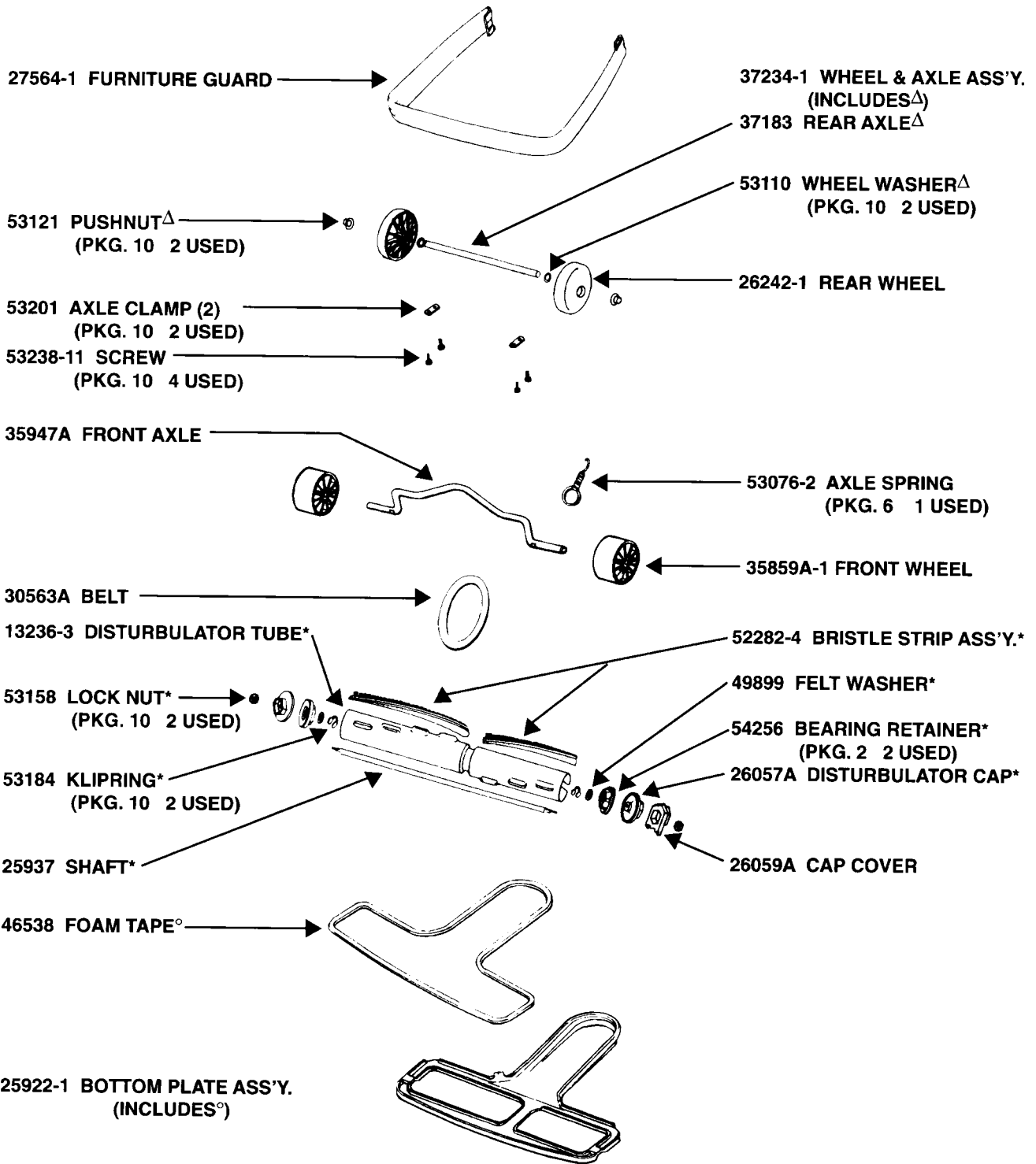

NOTE
 PT. NO. 53270
 DISTURBULATOR ASS'Y.
 INCLUDES*

54352-11 MOTOR ASSEMBLY

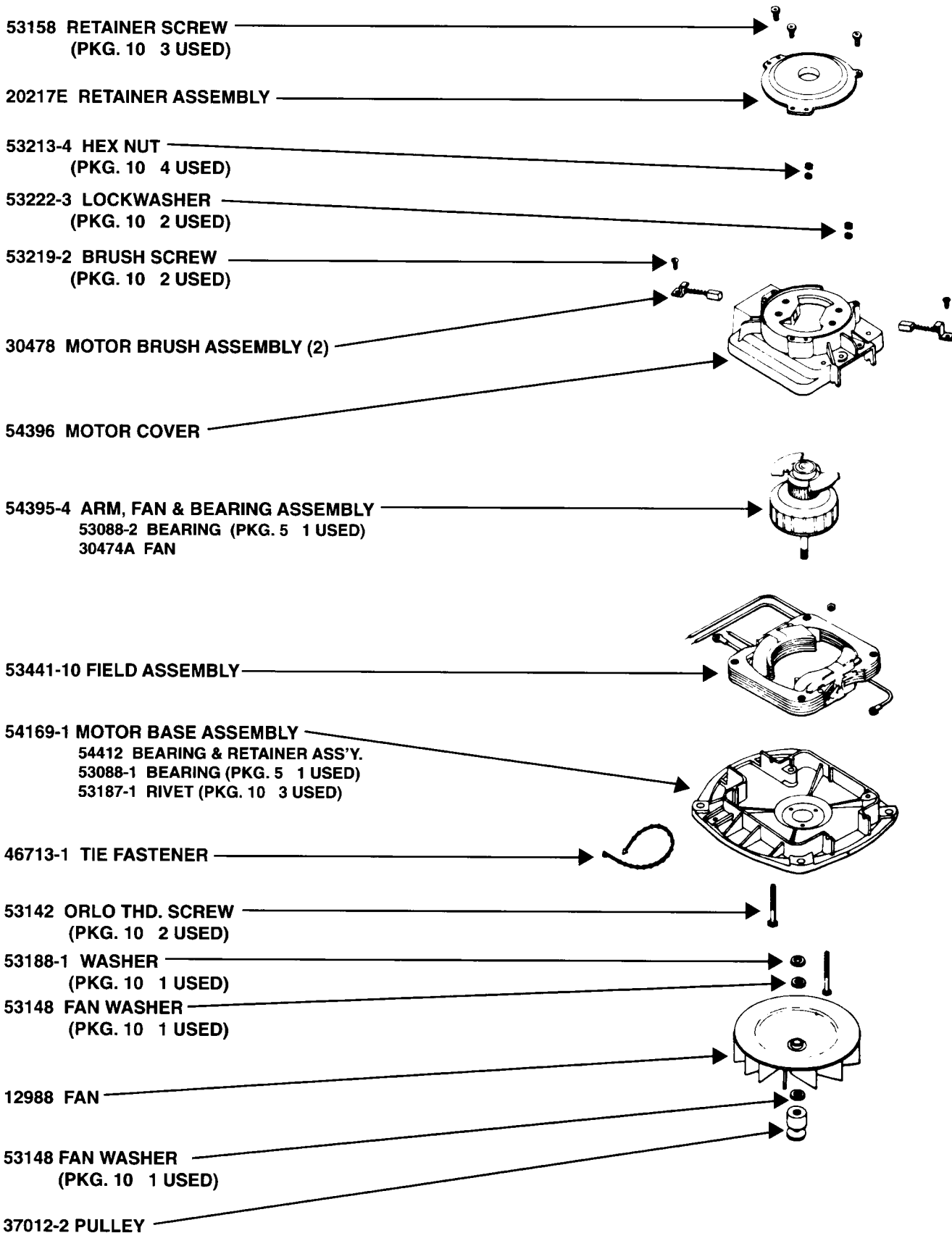

35293-8 HANDLE GRIP^Δ



53574-1 CORD RETAINER SET



38495 SPRING



25329-20 UPPER HANDLE ASS'Y.
(INCLUDES^Δ)

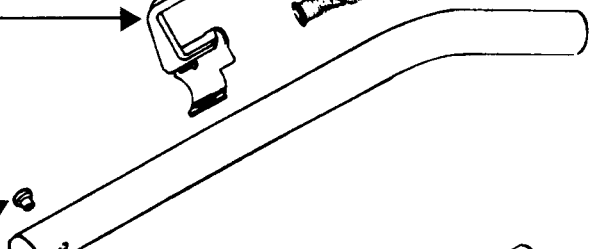

53198-1 SCREW & NUT ASS'Y.
(PKG. 6 1 USED)



12637-8 LOWER HANDLE TUBE

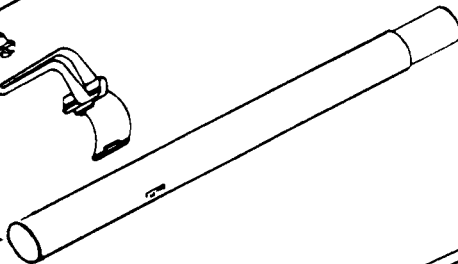

52370-12 SUPPLY CORD

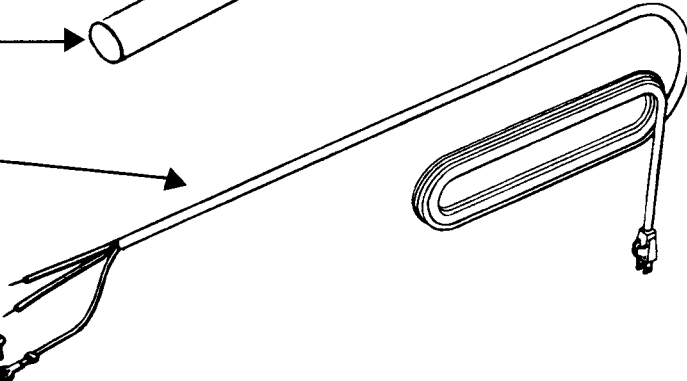

53228-2 SCREW
(PKG. 10 1 USED)



53198-1 SCREW & NUT
ASS'Y.
(PKG. 6 1 USED)

38183-1 HANDLE SOCKET ASS'Y.

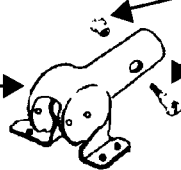

53238-13 SCREW (2)
(PKG. 10 2 USED)



53213-5 NUT
(PKG. 10 2 USED)



36439 HDLE. SOCKET SHEILD

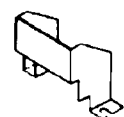

53145 BOLT
(PKG. 10 2 USED)



54582-1 BAG ASSEMBLY

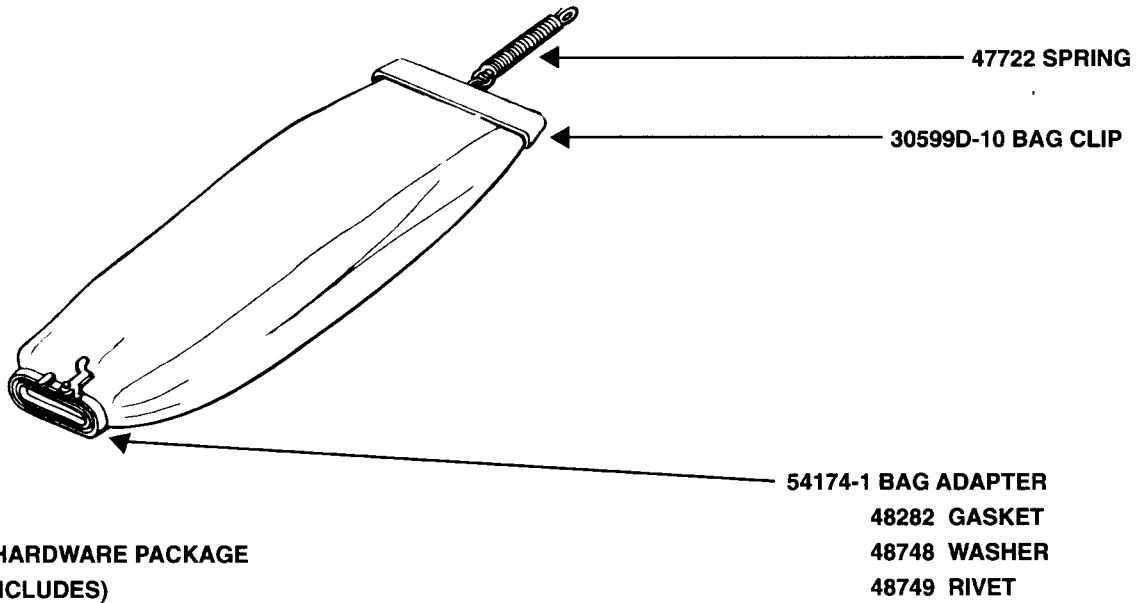

49461-A HARDWARE PACKAGE
(INCLUDES)
1-CORD RETAINER SET
2-HANDLE SCREW ASS'Y.

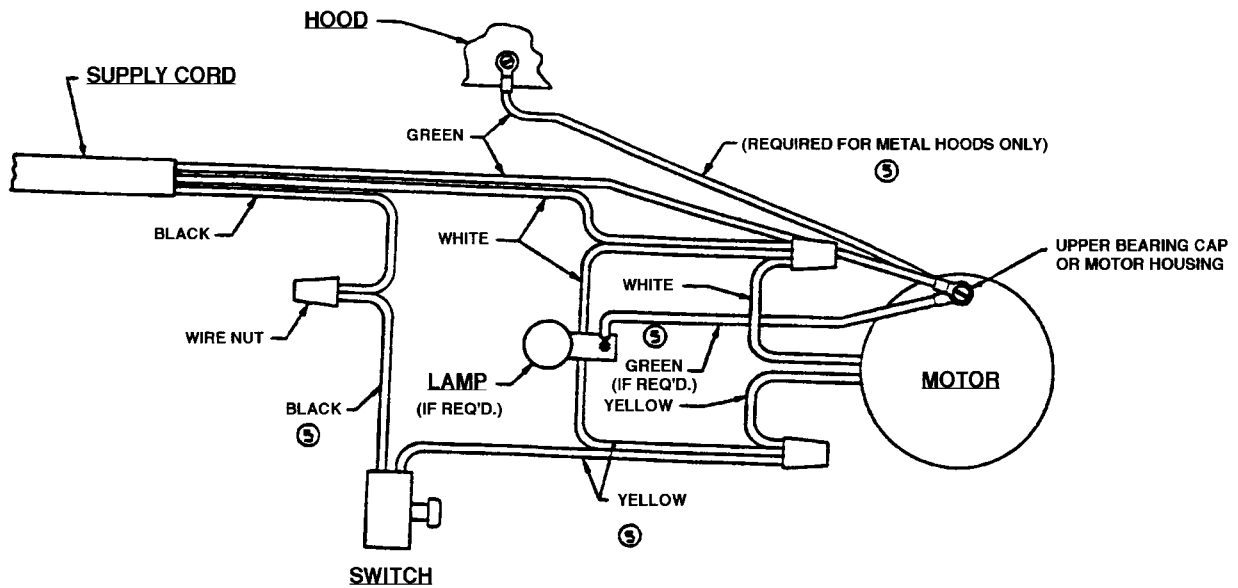

36575 WIRING DIAGRAM