

# Water Softener

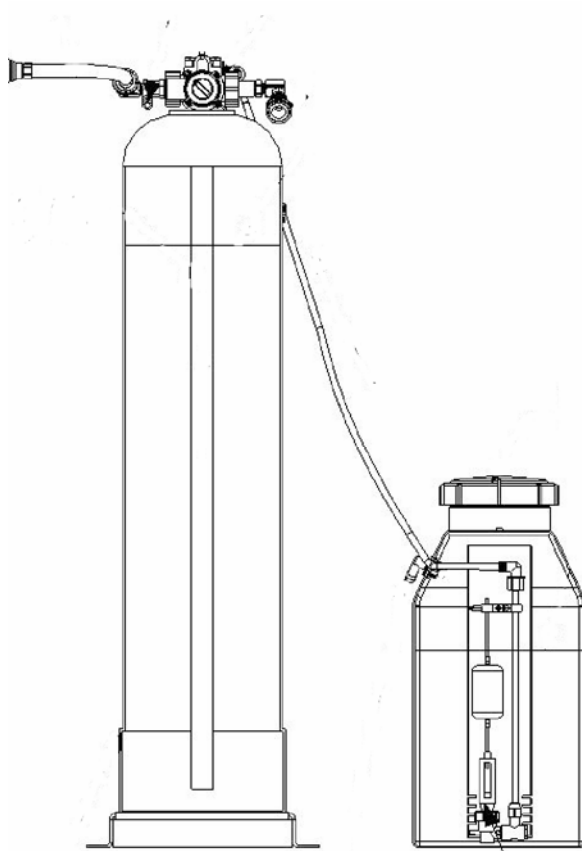

## Service and Operation Manual

**BLUELINE Equipment Co. LLC**

**2604 Liberator Dr., Prescott, AZ 86301 1-928-445-3030**

# Adobe acrobatINSTALLATION



## GENERAL INFORMATION:

1. When facing the front of the control the inlet is to the right and the outlet is to the left.
2. The system pressure must be between 20 psi and 120 psi.
3. If the system pressure is greater than 120 psi a pressure reducing valve must be installed.
4. The unit must be installed in accordance with local codes.
5. Do not over tighten connections.

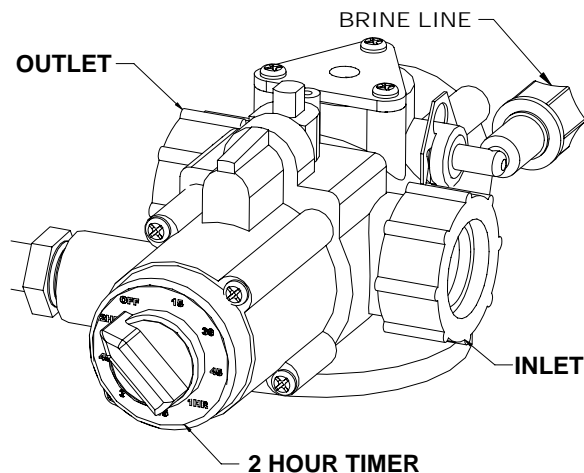

**23-043 CONTROLLER, WATER SOFTENER**

## SOFT WATER CONNECTION:

1. The supply line must be at least 1/2".

BLUELINE WATER SOFTENER

2. Teflon tape should be used when installing the drain fitting into the control valve.
3. The supply line must be free of kinks and obstructions.

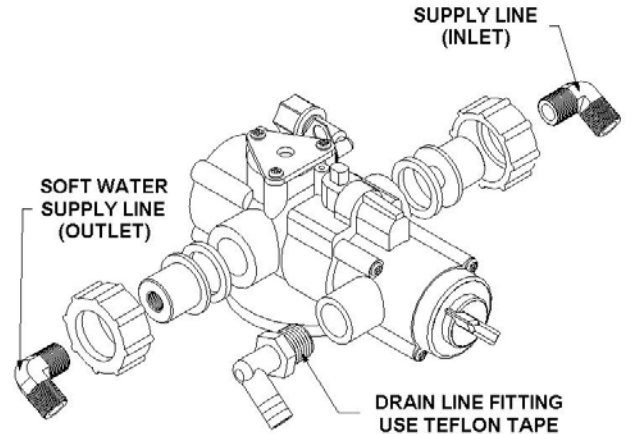

## BRINE LINE CONNECTION:

1. A safety float with an air check must be installed.
2. Insure all connections are tight.

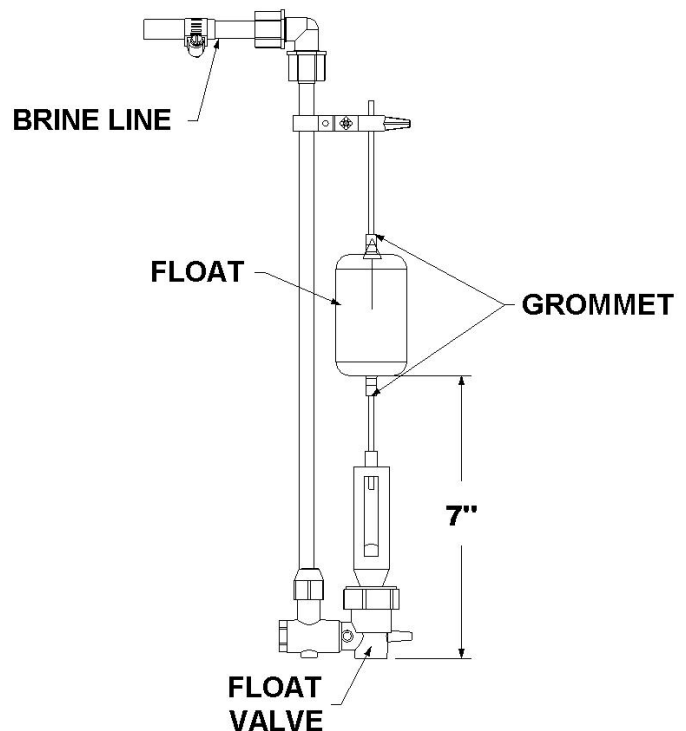

**23-042 VLV, FLOAT & BRINE WELL**

## FLOAT ADJUSTMENT

Raise Float Ball until it seats in lower valve.

Adjust grommets so the bottom of the float is 7" from the bottom of valve.

## FITTING KIT CONNECTIONS:

1. **DO NOT** use Teflon tape when connecting the Noryl nut to the control valve.
2. If the fittings require a sweat connection, care must be taken to prevent the Noryl nut from melting.
3. Place a wet rag over the copper tube and the Noryl nut prior to heating the tube.

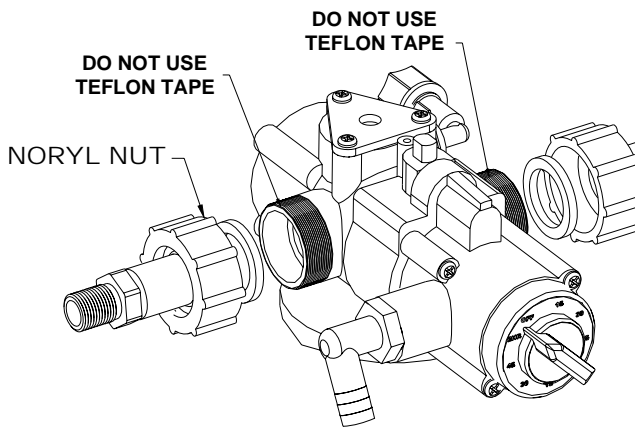

## OPERATION:

1. Connect water supply hoses and drain hoses. To initiate a regeneration, turn the twist timer knob to the desired time for brine/slow rinse.
2. Be sure to turn the timer past the 20 minute mark. When regeneration is completed the brine tank may be removed. Disconnect water inlet supply line and drain. Remove brine line and install provided plug.

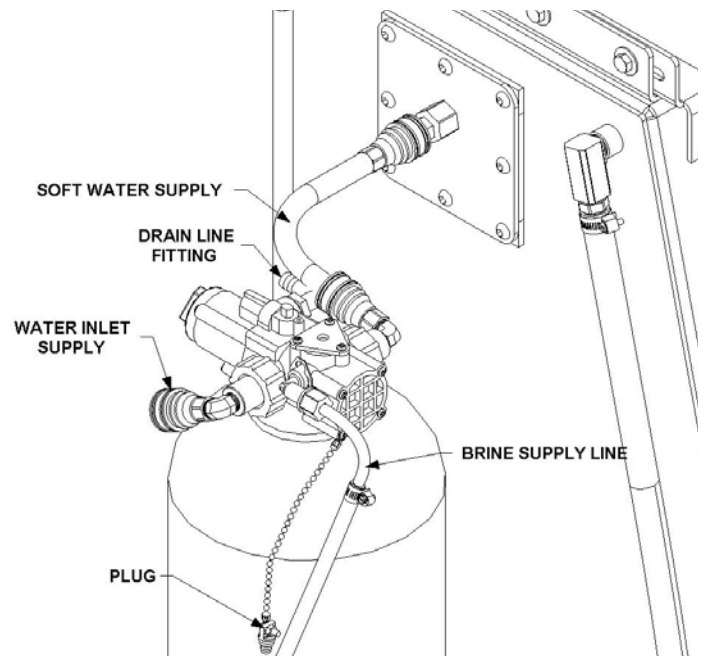

## BRINE DRAW/ SLOW RINSE CYCLE

In the brine draw/slow rinse cycle, concentrated brine is drawn from the brine tank and flows down through the riser tube, and up through the resin bed to the soft water supply line. Brine is drawn until the air check valve in the brine tank closes.

**NOTE:** This control valve operates with a pressurized brine line. The use of a safety float in conjunction with the air check valve is required.

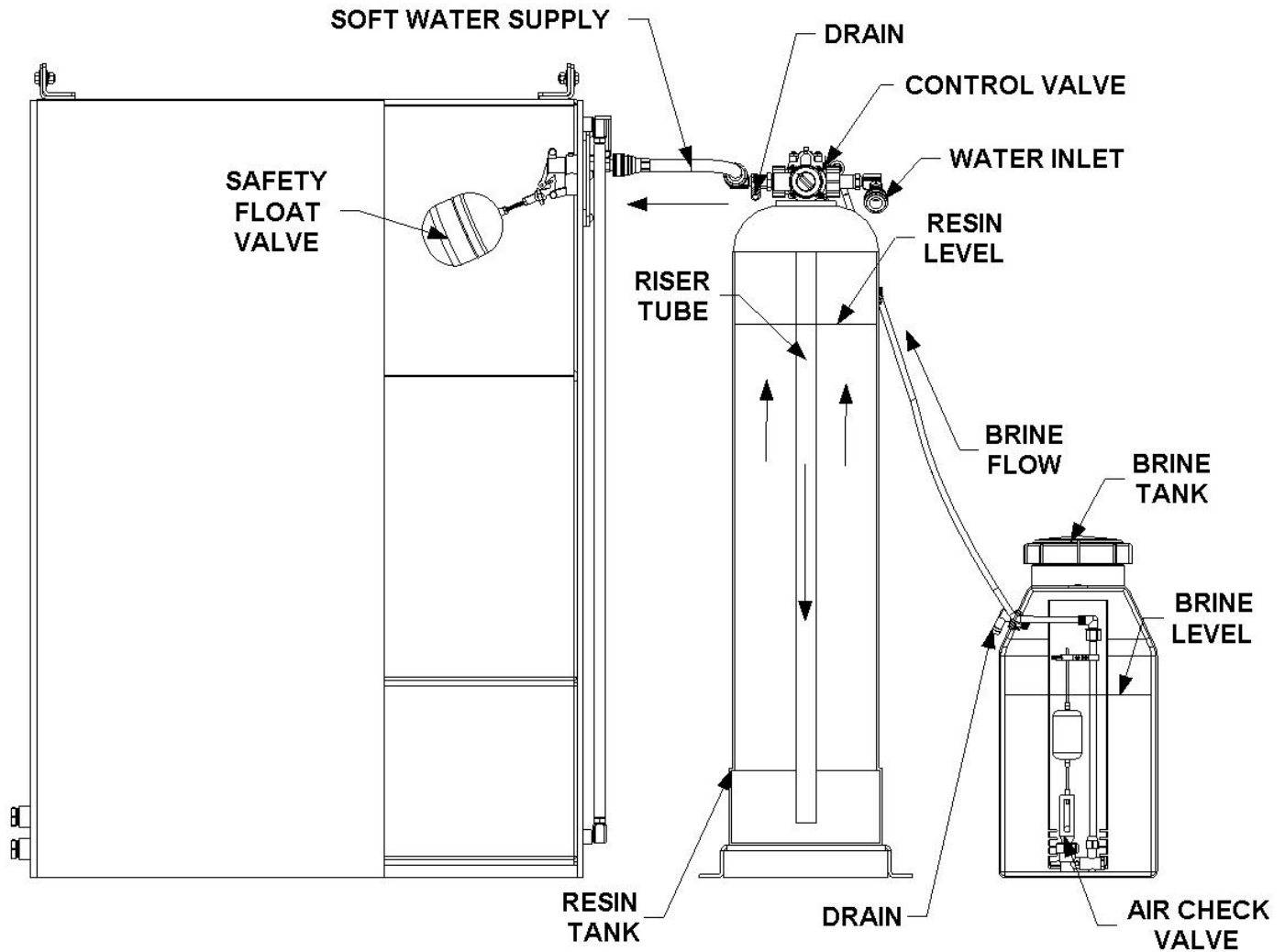

## SERVICE CYCLE

In the service cycle, untreated water is directed down through the resin bed in the resin tank and up through the riser tube. The water is conditioned when passing through the resin.

**NOTE:** This control valve operates with a pressurized brine line. The use of a safety float in conjunction with the air check valve is required.

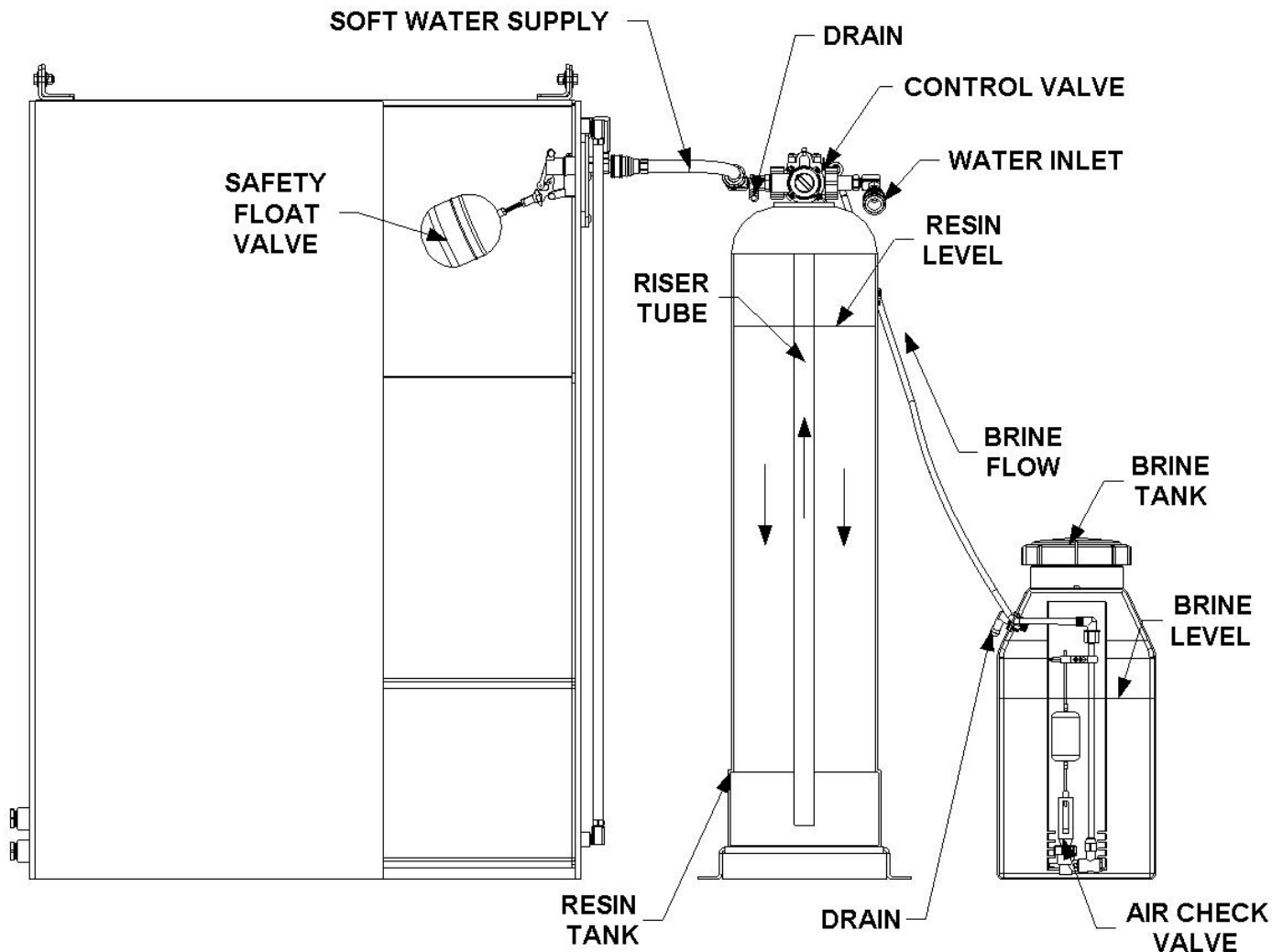

## WINTERIZING

It is recommended that resin tank and brine tank be removed and stored in a heated building during cold or freezing temperatures.

If a heated building is not available, disconnect water tank and brine tank. Connect an unrestricted hose to the discharge side of resin tank (soft water supply connection). Connect winterizing hose to water inlet. Turn on pump to circulate food grade anti-freeze or equivalent through the system.

### **WARNING!**

\*Use only food grade anti-freeze or equivalent when winterizing water softener resin tank. Follow anti-freeze manufacturers' recommendations for safe handling and disposal of anti-freeze.

**DO NOT** drain used anti-freeze on the ground or into storm drains. Dispose of anti-freeze only in an approved location. Observe Local, State and Federal laws when disposing of anti-freeze.

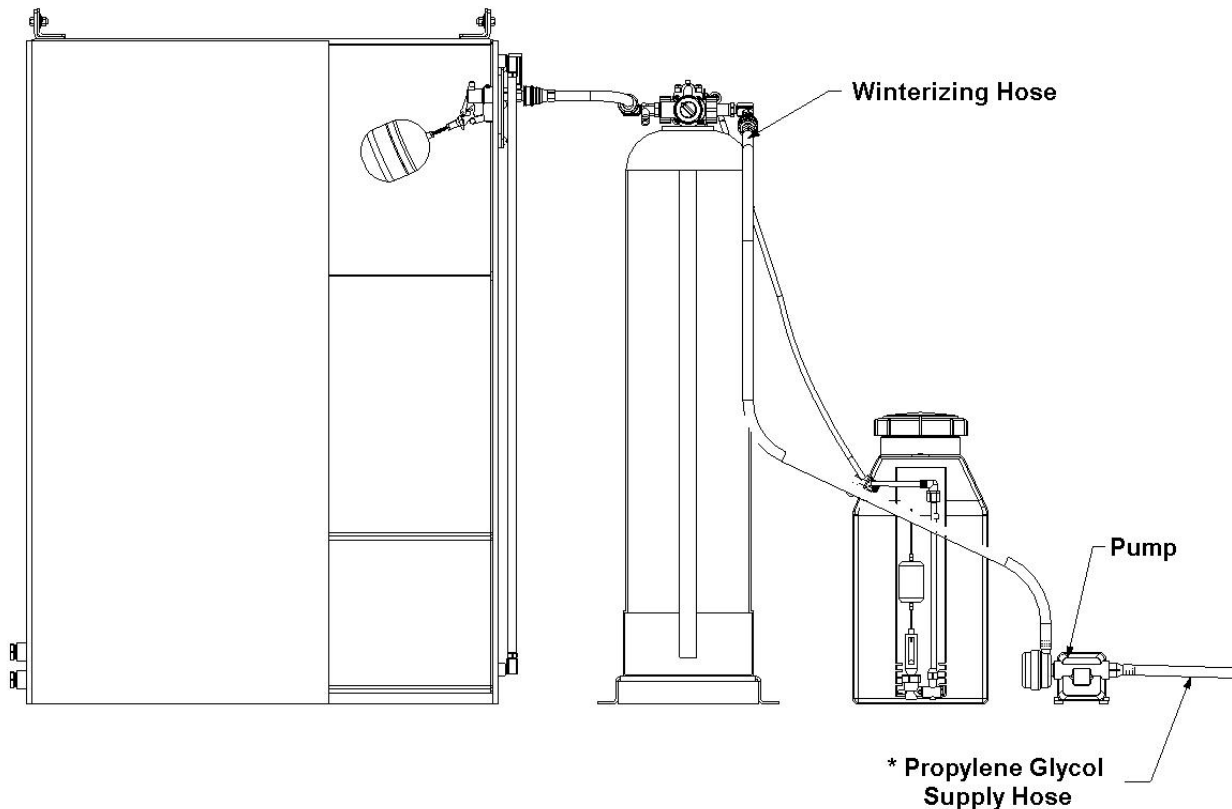

### 68-068 KIT, WATER SOFTENER WINTERIZING

Item No.	Part Number	Qty	Description
1	25-006	1	DSC, 3/8M X 3/8FP BR
2	21-014	1	FTTG, BRB 3/8 PX 1/2 H BR
3	14-011	3	CLAMP, HOSE FUEL #6
4	46-025	1	PUMP, FLOJET VAR. SPEED 4.5GPM
5	21-022	1	FTTF, BRB 1/2P X 3/4HPLSTC (8-156)
6	16-003	2	HOSE, WTR. 1/2 IN HRZ. 500FT BULK

# **TROUBLE SHOOTING:**

## **1. UNIT FAILS TO REGENERATE:**

A. Low inlet pressure.	A. Verify that the service inlet pressure is a minimum of 20 psi.
B. Supply line is restricted.	B. Insure that the supply line is free of kinks and obstructions.
C. The brine injector is plugged.	C. Clean or replace injector.
D. Main diaphragm is torn.	D. Replace diaphragm.
E. Regeneration length too short.	E. Insure that the regeneration time exceeds 20 minutes.

## **2. HARD WATER TO SERVICE:**

A. No salt in the brine tank.	A. Add salt.
B. Not enough water in the storage tank.	B. Verify that the air check valve is properly set.
C. Unit fails to draw brine.	C. See "5. SYSTEM FAILS TO DRAW BRINE:"
D. Excessive water usage.	D. Check regeneration frequency,
E. Unit not regenerating.	E. See "1. UNIT FAILS TO REGENERATE:"
F. Loss of resin.	F. See "4. LOSS OF RESIN:"
G. Change in raw water hardness.	G. Test water hardness.
H. Leak at the distributor tube.	H. Verify that the distributor tube is seated correctly and is not cracked.

## **3. EXCESSIVE SALT USAGE:**

A. Excessive water in storage tank.	A. Verify the safety float is properly set.
B. Faulty air check valve.	B. Replace air check valve.

## **4. LOSS OF RESIN:**

A. Faulty air check in brine tank.	A. Clean or replace air check.
B. Leak in the distributor tube.	B. Verify the distributor tube is seated correctly and is not cracked.

## **5. CONTROL FAILS TO DRAW BRINE:**

A. Brine injector is plugged.	A. Clean or replace injector.
B. Filter screen is plugged.	B. Clean or replace screen.
C. Loose brine line connection.	C. Verify that all brine line connections are tight, and aren't cracked or split.
D. Supply line is restricted.	D. Insure the supply line is not kinked or plugged and the safety float is properly working,
E. Low inlet pressure.	E. Verify that the service inlet pressure is a minimum of 20 psi. DO NOT exceed 120 psi.
F. Main diaphragm is torn.	F. Replace diaphragm.

## **6. CONTINUOUS FLOW TO DRAIN:**

A. Defective clock assembly.	A. Replace clock assembly.
------------------------------	----------------------------

## **7. LOSS OF WATER PRESSURE:**

A. Iron build-up in mineral tank.	A. Increase salt dosage or regenerate more frequently.
B. Lower distributor basket crushed.	B. Replace basket and verify that the distributor tube is cut 1/2 inch below the top of the tank threads.

## 21-137 Plug for top of softner

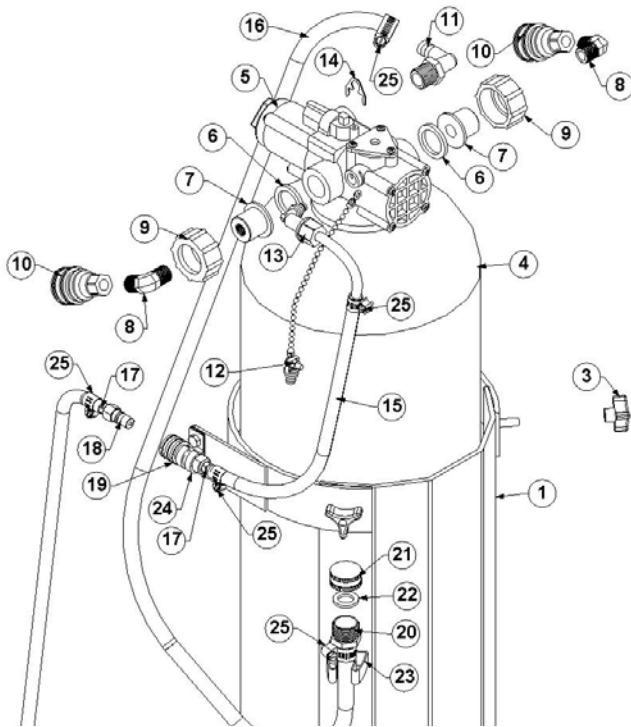

Item No.	Part Number	Qty	Description
1	61-114	1	ASSY, SUPPORT BASE TANK
2	58-095	1	BRKT, BRINE TANK STRAP
3	10-031	2	SCREW, THUMB 5/16-18 X 3/4
4	51-002	1	TANK, BRINE SOLUTION
5	23-043	1	CONTROLLER, WATER SOFTENER
6	41-036	2	WASHER, CONTROLLER BRINE TANK
7	66-101	2	FTTG, RESIN TANK FLANGED
8	21-161	2	FTTG, 3/8 M X 3/8 M 90 DEG
9	11-027	2	NUT, NORYL BRINE TANK
10	25-005	2	DSC, 3/8X3/8FP BR
11	21-136	1	FTTG, BULKHEAD 90 DEG X 1/2 BRB
12	68-049	1	ASSY, PLUG W/CHAIN WTR SOFTENER
13	21-139	1	FTTG, BRINE SOLUTION 90 DEG PLSTC
14	15-010	1	RING, SS RETAINING
15	16-038	1	HOSE, BRAIDED 3/8 ID 300FT BULK
16	16-003	1	HOSE, WTR. 1/2 IN HRZ. 500FT BULK
17	21-170	2	FTTG, 3/8 BARB X 1/8 M NPT
18	25-009	1	DSC, 1/8MX 1/8FP BR
19	25-010	1	DSC, 1/8FX1/8FP BR
20	21-169	1	FTTG, 1/2 BARB X 3/4M G HOSE
21	21-071	1	CAP, GARDEN HOSE 3-4 BRASS
22	41-038	1	WASHER, GARDEN HOSE CAP
23	15-015	1	SPRING, CLIP HOSE HOLDER
24	14-005	1	CLAMP, WIRE 1/2 IN X 1/4
25	14-011	5	CLAMP, HOSE FUEL #6

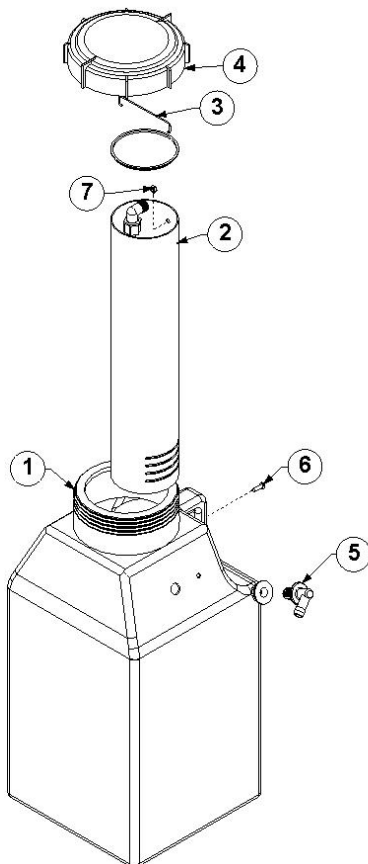

Item No.	Part Number	Qty	Description
1	51-013	1	MOLDING LARGE MOUTH JUG
2	23-042	1	VLV, FLOAT & BRINE WELL
3	15-014	1	CLIP, WIRE CAP RETAINER
4	21-025	1	CAP, 5 IN. WATER BOX/TANK BLACK
5	21-135	1	FTTG, OVERFLOW BRINE PLSTC
6	10-062	1	SCREW, MACH 10/32 X 5/8PPHZ
7	11-018	1	NUT, 10-32 NYLOK



