

# ScanCombiflex 650 PROPANE

## Manual



**SCANMASKIN**  
MACHINES-MINERALS-KNOW-HOW

[www.scanmaskin.com](http://www.scanmaskin.com)

Dear Customer!

Thank you for choosing Scanmaskin as your supplier.

We wish you all the best with your new ScanCombiflex™ 650 PROPANE and hope that it lives up to your expectations.

Scanmaskin Sverige AB

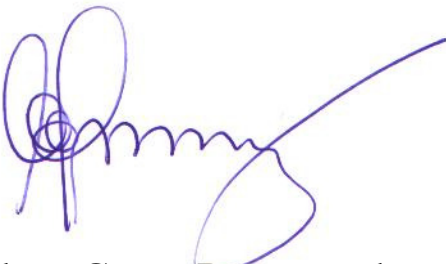

Claes-Göran Bergstrand  
Managing Director

Address:

Scanmaskin Sweden AB

Box 187

SE-437 22 Lindome / Gothenburg

Sweden

Telephone: +46 (0) 31 99 49 70

Fax: +46 (0) 31 99 48 70

[www.scanmaskin.com](http://www.scanmaskin.com)

## **Important Information!**

This Manual only concerns the floor grinding machines “**ScanCombiflex 650 PROPANE**” hereby referred to as “**SC 650 PROPANE**”. SC 650 PROPANE may only be used for grinding horizontal surfaces approved by Scanmaskin Sweden AB.

If SC 650 PROPANE is used for other purposes or handled in ways other than that described in this Manual, Scanmaskin Sweden AB disclaims all responsibility.

Especially note the section “*2Safety Regulations*”. Read the User Guide before using the floor grinding machine SC 650 PROPANE. The spare parts, grinding discs used on SC 650 PROPANE must be approved by Scanmaskin Sweden AB.

## Table of Contents

1	Specifications .....	2
1.1	Power specifications.....	2
1.2	Mechanical specifications .....	3
1.2.1	Water connection .....	3
1.3	Tools.....	4
1.4	Range of application .....	4
1.5	Scope of supply .....	5
1.6	Overview .....	6
2	Safety Regulations .....	7
2.1	Legend.....	7
2.2	Safety precautions .....	7
2.3	Propane safety .....	8
2.4	Fire Safety .....	8
2.5	Emissions .....	8
2.6	Hazard Communication .....	8
2.7	Local agencies and regulations .....	9
	• NFPA.....	9
2.8	Organizational measures .....	10
2.9	Personnel qualification.....	12
2.10	Safety regarding operation of machine.....	12
2.11	Electrical safety .....	13
2.12	Propane tanks.....	13
2.13	Refilling propane tanks.....	14
2.14	Storage propane tanks.....	14
2.15	Transporting propane tanks .....	14
2.16	Definition of the “Safety off position” .....	15
2.17	Safety regarding maintenance .....	15
2.18	Safety regarding transport .....	16
	2.18.1 Manual transport .....	16
	2.18.2 Lifting .....	16
	2.18.3 Inside vehicles.....	16
3	Transport.....	17
3.1	Precautions .....	17
3.2	Manual transport .....	17
3.3	Lifting.....	17
3.4	Inside vehicles .....	17
4	Operation .....	18
4.1	Preparation .....	18
4.2	Precautions .....	18
4.3	Operation of machine .....	18
4.4	Using the handle.....	19
4.5	Control panel.....	20
4.6	Propane tank.....	21
4.7	Water connection .....	21
4.8	Gas throttle .....	22
4.9	Start up .....	22
4.10	Stop.....	23
4.11	Emergency stop .....	23

4.12	Adjusting grinding speed.....	23
4.13	Safety off position .....	23
4.14	Grinding.....	23
4.15	Changing tools.....	24
5	Maintenance.....	25
5.1	Precautions .....	25
5.2	Daily inspection prior to operation .....	25
5.3	Maintenance and inspection list .....	26
5.4	Grinding disc replacement / assembly .....	26
5.5	Cleaning the machine.....	26
5.6	Trouble shooting .....	27
5.6.1	Troubleshooting.....	27
6	Spare Parts .....	28
6.1	Center axis .....	29
6.1	Reduction .....	32
7	Warranty .....	33
8	EU Declaration .....	34
9	Alphabetical reference .....	35
10	Contact information .....	36

# 1 Specifications

## 1.1 Power specifications

To find the specifications that apply to your machine, check the information plate at the back of the machine

<b>Engine</b>	Kawasaki FX603	18hp / 13,2kW
<b>Start battery</b>	12VDC	45Ah
<b>Fuse</b>	Next to start motor	20Amp
<b>Propane tank</b>	Steel	20lbs / 9kg

**Table 1-1** Power specifications

All models are CE-marked.

## 1.2 Mechanical specifications

<b>Model</b>	<b>SC 650 PROPANE</b>
<b>Grinding diameter</b>	26" / 650 mm
<b>Grinding plate diameter</b>	8,3" / 210 mm
<b>Grinding plate speed</b>	600 – 960 RPM
<b>Mass</b>	840lbs / 382 kg
<b>Gear barrel</b>	Synchronized

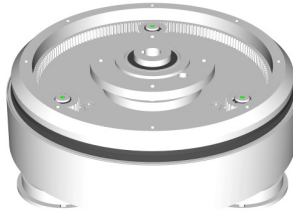

**Table 1-2** Mechanical specifications

### Measurements of SC 650 PROPANE

<b>Width</b>	650 mm	(26")
<b>Height</b>	1500mm	(59")
<b>Depth</b>	1120 mm	(44.1")

**Ambient temperature range during operation** -10°C to +50°C (14°F to 122°F)

**Ambient temperature range during storage** -40°C to +70°C (-40°F to 158°F)



When using water the ambient temperature must never fall below 0°C (32°F).

### 1.2.1 Water connection

Inside the cover of the gear barrel there is a sprinkler system connected to an external water connection. The water connection comes with its counterpart and fits a standard ½ inch hose. At the connection that is fitted near the handle there is a tap to adjust the flow.

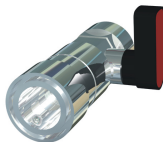



**Figure 1-1** Standard SC 650 PROPANE

### 1.3 Tools



*The machine must be equipped with tools approved by Scanmaskin Sweden AB before operation.*



*See “Grinding guide” for information about available tools and “4.15 Changing tools” for information about how to change the tools.*

The tools are fitted using the Scan-On system for easy fitting

#### Available tools

- Diamond tools
- SC-Tiger PCD

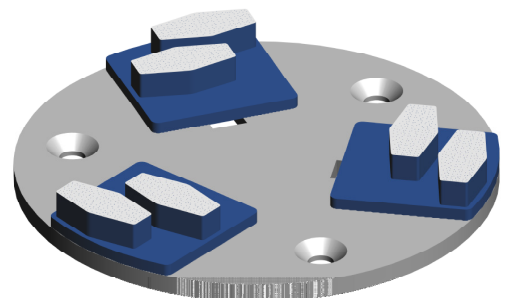

**Figure 1-2** Scan-On plate with tools fitted.

### 1.4 Range of application



*SC 650 PROPANE is exclusively designed to process horizontal surfaces. SC 650 PROPANE must not be used for other purposes than stated in this manual. The manufacturer will not be liable for damage or injury resulting from incorrect usage of SC 650 PROPANE. Failure to follow the directions in this Manual will void the warranty.*



## **Typical applications**

- Removal of old coatings, carpets, putty from hard surfaces
- Removal of undulated concrete surfaces
- Preparation of the surface for coatings
- Polishing of the surface
- Removal of coating defects
- Removal of glue residues

## **1.5 Scope of supply**

The following parts are included with the standard SC 650 PROPANE grinding machine:

- Start key
- Propane tank
- Manual

The machine has a water connection; the counter part for the connection will be included and fit in the water connection near the handle.

## 1.6 Overview



**Figure 1-3** Overview of SC 650 PROPANE

Item	Description	Reference / art no.
1	Handle	570627
2	Sprint to adjust handle	570039
3	Water connection	04.7Water connection
4	Nameplate	
5	Dust connection	780049 (O-ring)
6	Propane hose	
7	Propane tank	581072
8	Battery box	
9	Wheel	560121
10	Control panel	4.5Control panel
12	Engine	1.1Power specifications
13	Lift handle	3.3Lifting
14	Bolt machine head	560109
15	Grinding head	4.15Changing tools
16	Dust cover	581015





**Table 1-3** Machine parts overview

## 2 Safety Regulations



Read this entire chapter carefully! Failure to comply with safety regulations may result in serious injuries or damages.

### 2.1 Legend

	Notation regarding safety
	Notation regarding electrical safety
	Notation regarding safety during transport
	Tipping hazard
	See reference

### 2.2 Safety precautions



Any machine, if it is not used according the regulations, may be hazardous for operating, setting-up and service personnel. The operating authority is responsible for compliance with the safety regulations during operation and maintenance, and for the use of safety devices supplied with the machine, as well as the provision of appropriate additional safety devices!

Eye and ear protection must be worn at all times.

Never operate the machine when it's not in its upright position.

Make sure there is no debris in the work area.

Check the work area for screws or other hard objects in the surface. Don't use the machine if there are any foreign objects stuck into the surface. Such objects must be removed prior to operation of machine.



Read “2.33 Propane safety and “2.10 Safety regarding operation of machine” thoroughly before operation!

## 2.3 Propane safety

Propane is a flammable gas whose vapors are heavier than air. As in the case with gasoline, propane can explode if the proper cautions are not heeded. Propane is odorized with an agent having a distinct odor that is recognizable at very low concentrations. This helps identifying leaks, even when they are small.

Awareness and basic safety precautions are required when working with propane. As long as these precautions are followed, risk is negligible. Ignorance, however, could pose needless risk.

The two greatest hazards with propane powered floor machines are:



- **Carbone Monoxide Poisoning:** This is the most frequently reported incident associated with propane powered machines and is caused by excessive exhaust emissions. The symptoms are headache, dizziness and nausea. A major cause involves engines with poor preventive maintenance practices. Usually those with dirty air filters and machines operated in confined areas without adequate ventilation. Another cause may be substandard, inexpensive machines with no emission control technology and improperly set carburetion.
- **Overfill Fuel Tanks:** Nearly all fire related incidents reported result from bringing a tank into a building without first checking for overfill. This action is dangerous, unwise and unnecessary.

## 2.4 Fire Safety



- Beware of the potential danger of fire or explosion when using propane, and take normal fire-safety precautions.

**Fire:** There is possibilities of fire from LPG vapor Leaking or venting from fuel tanks or carburetion equipment.

**Explosion:** LPG vapor concentrated or confined to a small, restricted space may explode or ignite.

**Propane** may experience a **BLEVE**, a boiling liquid expanding vapor explosion.

## 2.5 Emissions

- All propane powered floor machines produce emissions. Most are harmless, but some are dangerous and can be fatal. Carbon monoxide (CO) poses the greatest risk, since CO can be lethal within as little as 30 minutes exposure at 3,000 parts per million (ppm) concentrations.
- Carbon monoxide is an invisible odorless colorless gas created when fossil fules (such as gasoline, wood, coal, propane, oil and methane) burn incompletely.

## 2.6 Hazard Communication

A **Material Safety Data Sheet** for propane shall be posted in all buildings where propane will be used.

Because propane is odorized, it is easily detected at levels of just a few parts per million, which is much less than the exposure limit of 1000 parts per million.



- **If you smell propane while operating a propane floor machine, do the following:**

1. Stop the engine: Push the throttle to the stop position turn the key switch to the off position.
2. Shut off the service valve on the propane cylinder.
3. Move the floor machine to a well-ventilated area.
4. Remove the cylinder from the machine and take it outside the building.
5. If the cylinder is leaking, contact a DOT approved repair shop to determine the cause of the leak and have the shop, not you, repair it.



• **If a fire occurs while the machine is being operated do the following:**

1. Stop the engine: pull the throttle to the stop position (if present) or turn the key switch to the off position.
2. Shut off the service valve on the propane cylinder if possible. Be careful not to be burned.
3. Move the machine outside if possible. If not possible, move it to a well-ventilated area away from flammable materials.
4. Do not attempt to extinguish the flame from a gas leak. If you do, the gas will build up in the area and could re-ignite. Starve the fire by shutting off the supply of gas.
5. Have the machine and cylinder inspected before using them again.

## **2.7 Local agencies and regulations**

• **NFPA**

Operating a propane powered floor machine requires compliance with certain safety regulations.

The National Fire Protection Agency (NFPA) Standard for Storage and Handling of **LP** Gas is the appropriate authority for safe propane use. A copy of this publication is available through the NPFA in Quincy, MA (1-800-334-3555). Among its regulations, NFPA #58 requires that all personnel employed in the handling of propane gas be trained in its proper handling and operating procedures. It also requires them to carry a written certification from their employer or training supervisor to attest to such training. Although this is directed mainly to those who fill and transport liquid propane gas, Onyx Environmental Solutions recommends that operators of propane powered floor care machines in public places be trained and certified as well.

With regard to operation of propane powered floor care equipment, even though NFPA 58 8-4.5 says "these machines shall be permitted to be used in buildings frequented by the public, including the times when such buildings are occupied by the public," Onyx Environmental Solutions suggests usage when occupancy of a given work area is minimal.

• **CARB/EPA**

The California Air Resource Board (CARB) and Environmental Protection Agency (EPA) also set limits for propane-powered engines used outdoors, but CARB/EPA approval does not signify that the engine is safe to **use** indoors.

• **CGA**

The Canadian Gas Association (CGA) has set a limit of 1500 ppm CO in exhaust flow.

- **OSHA**

For propane powered machines used indoors, the Occupational Health and Safety Administration (OSHA) has established a limit of 50 ppm CO for 8-hour time weighted average (TWA) in ambient air and is considering a limit of 800 ppm CO in exhaust flow.

- **DOT**

The Department of Transportation (DOT) has established regulations regarding the safety of fuel tanks including the ones used on propane powered floor care machines.

- **Local Agencies**

Local law enforcement agencies such as the local Fire Marshall also rely on independent testing labs such as UL and CGA before giving their approval of the use of some equipment. These labs thoroughly test equipment and submit their stamp of approval only after rigorous testing.

While not being required by all law enforcement agencies, the stamp of approval by these agencies further assures the operator that he or she is working with and around safe equipment.

**NOTE:** In order to reduce all consequences of the abovementioned risks, we advise that machine operators will follow the instructions in the manual at all times.

### **RESIDUAL RISKS**



During the normal operating and maintenance cycles, the operator is exposed to few residual risks, which cannot be eliminated due to the nature of the operations.

## **2.8 Organizational measures**



The Manual is to be kept near the location where the machine is being operated and must be within reach at all times.

In addition to this Manual general and legal regulations regarding accident prevention and environmental protection must be complied with as per local regulations.

Such duties may, for example, relate to the handling of hazardous substances, or to the provision and wearing of personal protection equipment, as well as compliance with traffic regulations.

The Manual must be supplemented by other instructions, including the duty to supervise and report incidents relating to particular working practices, for example work organization, work procedures and personnel safety.

Personnel entrusted with working with the machine must read the Manual before starting work, in particular the “*2Safety Regulations*” chapter. To read these instructions after work

is commenced is too late. This particularly applies to incidental activities such as setting up the equipment, carrying out maintenance work or training staff to work with the machine.

From time to time the working practices of the operators are to be checked by a supervisor especially to the items regarding awareness of safety and hazards.

Always wear Carbon Monoxide Indicator badges as an extra precaution.

The plastic indicator contains a colored indicator button that darkens in the presence of Carbon Monoxide. The relative darkness of the indicator button indicates the level of CO in the ambient atmosphere. Most indicator badges have a useful life of 30 days, depending on the concentration of contaminants, humidity, and temperature.

Operators must tie back long hair, and not wear loose clothing or jewelry including rings. There is a risk of injury through items getting caught, or being drawn into moving machinery.

Eye and ear protection must be worn at all times!

Use personnel protection equipment if necessary or required by local regulations! Take notice of all safety and hazard notices on the machine!

All safety and hazard notices at or on the machine must be kept complete and legible!

If safety-critical changes occur to the machine or its working method, the machine must be shut down immediately! The cause of the fault must be established, and rectified.

Changes, add-ons or conversion to the machine, which might impair safety, must not be made, without the manufacturer's permission!

This applies in particular to the fitting and adjustment of safety devices.

Spare parts must comply with the technical requirements specified by the manufacturer. This is always guaranteed if original spare parts are used.

Intervals for recurring checks and inspections specified in this Manual must be complied with!

To perform maintenance work correctly it is imperative to be equipped with the proper tools for the task in question.

Repairs may only be made by Scanmaskin Sweden AB certified service technicians.

Some grinding work may generate sparks under certain circumstances. Personnel working with the machine must therefore be aware of the risk of fire and how to handle a fire situation properly.

Do not use the machine in areas with highly flammable and/or explosive materials.



## **2.9 Personnel qualification**

### **Fundamental duties:**

- Work on the machine may only be undertaken by trained personnel.
- Specify clearly the responsibilities of personnel for operation, setting up, servicing and maintenance work!
- Make sure that only authorized personnel operate or work on the machine!
- Define responsibilities of the machine operator, with regard to traffic safety regulations, and inform him not to take instructions from third parties who may not be complying with the local safety requirements.
- Personnel, who are being trained to operate equipment, may only use the machine under constant supervision of an experienced person!
- Work on electrical equipment may only be undertaken by a skilled electrician or by trained persons under the supervision of a skilled electrician, as well as in accordance with the local electrical engineering regulations.

## **2.10 Safety regarding operation of machine**



Do not allow any method of working that impairs safety!

Recognized official procedures have to be used to ensure the machine is operated in safe and best conditions.

Only operate the machine when all safety devices and related safety equipment are present and operational!

Check the machine visually for any damage and defects at least once a day.

In the event of operational malfunctions the machine must be shut down immediately and secured!

Secure the work area around the machine in public areas providing a safety distance of at least 10 m (3.3 ft) from the machine.

Faults must be immediately rectified.

Carry out the switch on, and switch off operations in accordance with this Manual.

Before turning on the machine make sure that no-one can be endangered when the machine starts up.

Never operate the machine when not in its upright position.



Do not switch off or remove the exhaust and or the ventilation devices whilst the machine is running!

All persons in the proximity of the machine must wear ear and eye protection as well as safety shoes. In addition the machine operator must wear close-fitting protective clothing.

Make sure there is no debris in the work area.

Check the work area for screws or other hard objects in the concrete. Don't use the machine if there are any foreign objects stuck into the surface. Such objects must be removed prior to operation of machine

## 2.11 Electrical safety



The battery power source must be equipped fused according to the table in “*1.1 Power specifications*”.

Work on electrical equipment may only be undertaken by a skilled electrician or by trained persons under the supervision of a skilled electrician as well as in accordance with the local electrical engineering regulations.

The work area must be secured against any third party entering the work area. Follow local electrical engineering regulations while working on the machine. Never leave a machine unattended. Use only tools that are insulated against electricity.

Only start work after you are familiar with the electrical engineering regulations that apply to the local area.

Only use voltage seekers that comply with the regulations when troubleshooting. From time to time check voltage seekers to ensure that they are operationally efficient.

## 2.12 Propane tanks



The Propane tanks are constructed of either aluminum or steel. The tank used on propane powered floor machines is classified as a 4E240 cylinder. Its rated capacity is 20lbs. and this designation refers to the model of the tank. Actual propane capacity achieved during filling can be less than, equal to, or slightly more than 20 lbs. Use only UL, CTC/DOT listed tanks.

- The propane tanks used on the floor machine is a motor fuel cylinder as listed by the Department of Transportation. Unlike the common 20-lb propane outdoor grill tanks (which are not legal for use on propane floor machines), the motor fuel cylinder has a number of safety systems designed into it to ensure your safety at all times.

## 2.13 Refilling propane tanks



The proper filling of propane tanks is a subject so important that it warrants special attention. Propane tanks should only be filled by qualified propane dealers.

- Most important, propane tanks should be filled no more than 80% of their rated capacity. The other 20%, which is about 4" (10 cm) from the top of the cylinder, is called the vapor space or headspace. This vapor can be compressed without causing the pressure relief valve to open and vent gas to the area around the cylinder. If there is no headspace to allow for fuel expansion, the pressure relief valve will open, releasing propane gas into the atmosphere. This is a very dangerous and volatile situation as there is always the possibility that enough of the vented gas could find its way down to the floor and come in contact with a pilot light from a furnace, hot water heater, or other source of ignition. Propane changes into a gas, is -44" F (-42° C). Exposing unprotected skin to propane gas or liquid could result in frostbite injury.
- All new tanks should be vented and purged of air per manufacturer's instructions before use. Never bleed propane tanks indoors.

## 2.14 Storage propane tanks



When not in use, propane tanks always should be stored outside in an upright position in a secure, tamperproof, steel mesh storage cabinet. This cabinet may be located next to the building but with at least five feet (1.5 m) of space between the cabinet and the nearest building opening (door or window), also away from heat and direct sunlight.

## 2.15 Transporting propane tanks



When transporting cylinders to a propane dealer or to a job, make sure the cylinders are securely fastened and standing in an upright position with the service valve closed.

- A cylinder rattling around in the back of a vehicle and banging into other objects constitutes a hazard. Avoid dropping or banging cylinders against sharp objects.
- The propane cylinders are sturdily constructed but a series of hard jolts could cause damage.
- Please note that any cylinder that has been filled is always considered full, no matter how little propane gas remains in it. This is because even when all liquid has evaporated into vapor there is still some propane gas vapor left in the cylinder. Because this remaining fuel is flammable, an empty cylinder should be treated with the same careful procedures as one that is filled to the 80% level with liquid propane. The only time that a cylinder is considered empty is when it is new, before it has been filled with propane.
- When transporting a propane powered floor machine, the propane cylinder may be strapped onto the machine as long as the machine itself is firmly secured in the vehicle.
- Of course, spare cylinders should always be secured in an upright position

## 2.16 Definition of the “Safety off position”

*The machine is in a safe condition where it cannot be any hazard.*

### How to set the machine in the Safety off position:

1. Turn off the machine, with minimum throttle and remove the Start key
2. If a dust collector is used, switch it off
3. Wait for all drives to come to a complete stop
4. Press down the emergency button, close the valve on the propane tank
5. Secure against unintended restart



*Always remove the start key on the machine to prevent other persons from accidentally starting it while working on the machine.*

## 2.17 Safety regarding maintenance

Set the machine into the Safety off position before beginning any work on the machine.



*See “2.16 Definition of the “Safety off position””.*

Never work on the machine while battery or propane tank still is connected!  
All parts must have come to a complete stop before beginning any work!



*When the machine is lying down on its back it might tilt to it's upwards position. Take extra care to prevent this from happening to ensure that no injuries or damages occur.*



*When the machine has been operated the segments, Scan-On plates and other parts on the gear barrel may be hot. Take extra care to prevent burn injuries.*

Adjustment, servicing and inspection work on the period of time limits, specified in this User Manual as well as any information on the replacement or parts and equipment must be undertaken and/or complied with!

These activities may only be undertaken by qualified personnel.



*When the machine has been operated the Kawasaki motor is extremely hot. Take extra care to prevent burn injuries.*



*See “2.16 Definition of the “Safety off position”” for further information.*

## **2.18 Safety regarding transport**



*Always remove the tools before transport. The tools may fall off or damage the surface the machine is transported along.*

### **2.18.1 Manual transport**



*When transporting the machine manually be observant about ramps and/or edges.  
Follow local traffic regulations for the work site to prevent accidents. Failure to comply with these regulations may cause injuries or damages.*

### **2.18.2 Lifting**



*The machine must be secured according to local safety regulations before lifted.  
No person is allowed beneath a lifted machine! The machine must be lifted according to the instructions in “3.3Lifting” Observe the machines point of balance before lifting! Failure to comply with these regulations may cause injuries or damages. Only use straps approved for the weight and circumstances!*

### **2.18.3 Inside vehicles**



*Secure the machine according to local transport safety regulations before transporting the machine inside a vehicle.*

## 3 Transport

### 3.1 Precautions



Read “2.18 Safety regarding transport” before attempting to transport the machine.

### 3.2 Manual transport

- Detach the tools according to the instructions in “4.15 Changing tools”.
- Push the handle downwards to lift the gear barrel about 10 cm (4”) from the ground.
- Push the machine in desired direction.

### 3.3 Lifting



Before attempting to lift the machine, read “2.18.2 Lifting”

- Detach the tools according to the instructions in “4.15 Changing tools”.
- Fasten the straps used for lifting at the two handles as shown in “Figure 3-1”.
- Lift the machine.

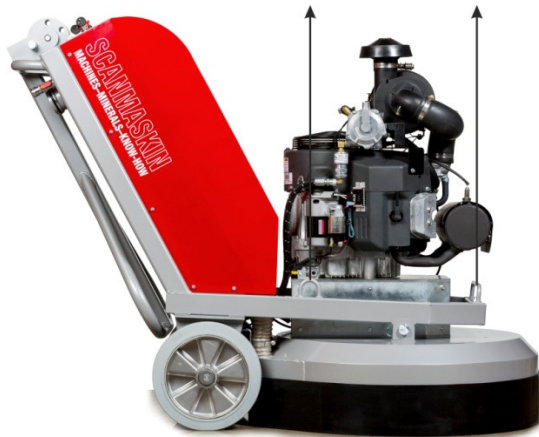

Figure 3-1 Lifting points

### 3.4 Inside vehicles

- Detach the tools according to the instruction in “4.15 Changing tools”.
- Secure the machine inside the vehicle.

## 4 Operation

### 4.1 Preparation



Before first start-up make sure that the oil level is correct by checking the oil gauge filler. Choose engine oil that follows API Service Classification: SF, SG, SH, SJ or SL. Choose viscosity according to temperature were the machine will be operated.

### 4.2 Precautions



Any machine, if it is not used according the regulations, may be hazardous for operating, setting-up and service personnel. The operating authority is responsible for compliance with the safety regulations during operation and maintenance, and for the use of safety devices supplied with the machine, as well as the provision of appropriate additional safety devices!

All propane connections and cables must be inspected for potential damages.

Never operate the machine without proper tools.

Eye and ear protection must be worn at all times.

Never operate the machine when it's not in its upright position.

Make sure there is no debris in the work area.

Check the work area for screws or other hard objects in the concrete. Don't use the machine if there are any foreign objects stuck into the surface. Such objects must be removed prior to operation of machine.



Read "*2Safety Regulations*" before operating the machine.

### 4.3 Operation of machine

The gear barrel has got three grinding heads that rotates in the opposite direction of the gear barrel. Each grinding head is equipped with a Scan-on plate where each plate hold the tools used. See "*Figure 4-1*".



**Figure 4-1** Illustrates the rotation of the grinding heads versus the gear barrel.

#### **4.4 Using the handle**



**Figure 4-2** Secure the handle



**Figure 4-3** Handle upraised



**Figure 4-4** Handle in working position



**Figure 4-5** Handle lowered



Figure	Description	
4-2	Secure the handle	Secure the handle in three positions
4-3	Handle upraised	In this position it's possible to lean the machine backwards and change grinding tools. Also the position to move around the machine leaning back.
4-4	Handle working position	This is the normal working position
4-5	Handle lowered	In this position it's also possible to work, mainly if the working areas that is tighter and the operator benefits on the machine short length.

### 4.5 Control panel

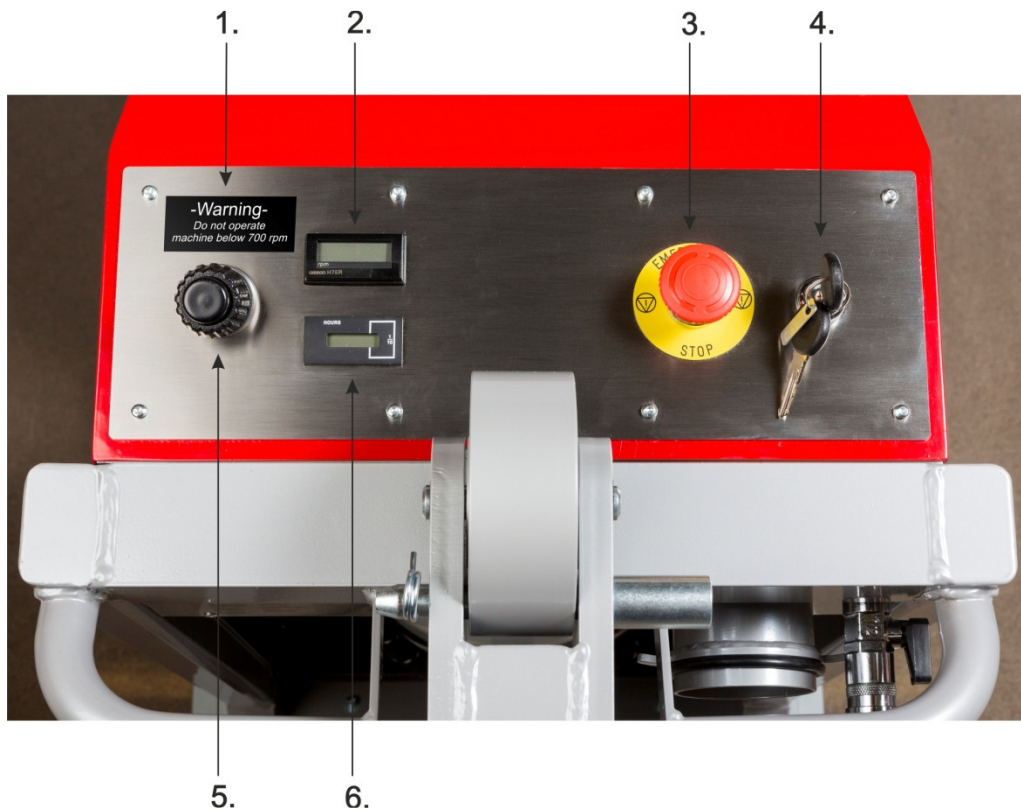

Figure 4-4 Control panel of SC-800 Propane.

Item	Text	Description	
1	-Warning-	Do not operate machine below 750rpm	581105
2	RPM	Machine head speed	581069
3	EMERGENCY STOP	Emergency stop	596003
4	START KEY [0-RUN-START]	Starts and stops machine	581094
5	Speed	Adjust engine speed	530072
6	Hours	Machine operating hours	570028



**Table 4-1** Description of the control panel.

### 4.6 Propane tank

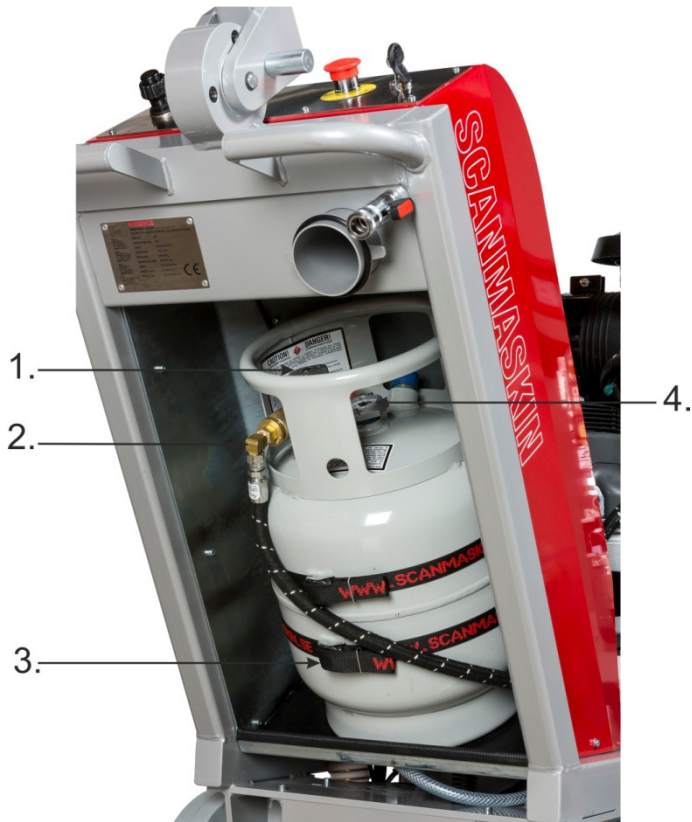

**Figure 4-5** Propane tank .

Item	Part	Description
1	Valve	Turn clockwise to close
2	Quick connection	Connection to engine
3	Straps	Secure propane tank
4	Sight gauge	Level of propane left

### 4.7 Water connection

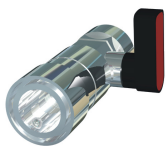

**Closed** – No water will flow

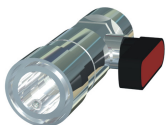

**Open** – Water will flow

## 4.8 Gas throttle

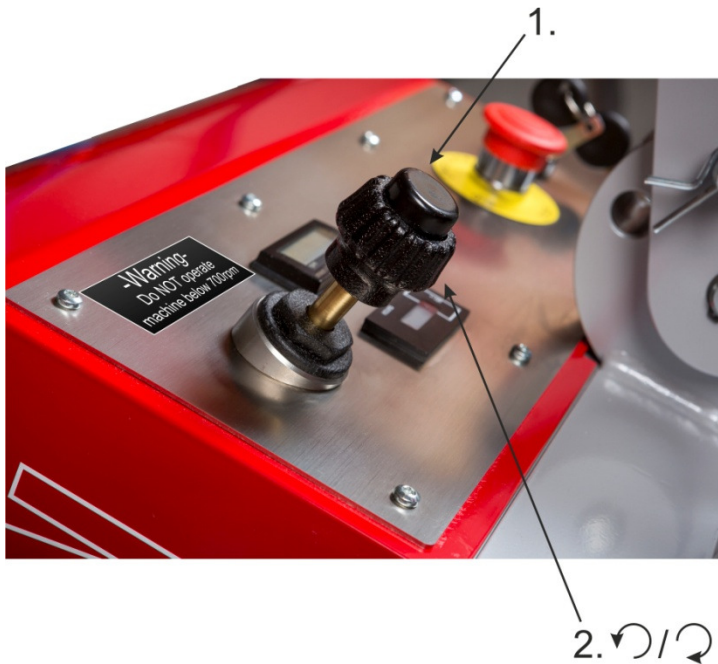

Figure 4-6 Gas Throttle

No.	Description
1	Hit nob for fast stopping
2	Lift & turn to adjust speed

## 4.9 Start up



See "4.1 Preparation

Before first start-up make sure that the oil level is correct by checking the oil gauge filler. Choose engine oil that follows API Service Classification: SF, SG, SH, SJ or SL. Choose viscosity according to temperature were the machine will be operated.

**Precautions** before starting the machine.

### How to start the machine

- Check the engine oil.
- Make sure that proper grinding tools is attach to the machine "4.15 Changing tools" check the grinding guide for best choice.
- Make sure that the propane tank and hoses for dust collector and water (if used) are connected to the machine and well secured.
- Make sure that the handle is in working position See "4.4 Using the handle"
- Turn on the valve on the propane tank
- Turn on the dust collector if used.
- Make sure that the "EMERGENCY STOP" button (3) is in its upper position. If not, release it by turning it clock wise until it rises.

- Make sure that the throttle nob is in its lower position, this is done by pushing it down.
- Turn the start key clockwise until the start motor engage. Normally the engine will start within 3 seconds. **Do not run the electric starter continuously for more than 6 seconds, otherwise the battery may discharge quickly. If the engine does not start right away, wait 15 seconds and try again.** If the engine doesn't start carefully lift the throttle nob and try to start again.



- Note that when the engine starts the machine may start grinding because of the position of the throttle, Push the throttle nob to reach idle speed.
- Let the machine run on idle speed for at least 3 minutes before increasing the speed of the engine. This will warm up the engine and allow the oil to reach all engine parts.
- To start grinding first lift and then turn the throttle to left. The mechanism will make sure that the speed always stays above 750rpm.

## 4.10 Stop

### How to stop the machine

- Turn the throttle clock-wise to its inner position and then push it down for a complete stop.
- Wait for the machine to come to a complete stop before letting go of the handle.
- Turn the start key to "0" to turn off the engine. / Or turn of the valve on the propane tank to let the engine run until it stops from lack of propane. (this is recommended if the work has come to an end) Do not forget to turn the key to "0".
- Turn off the dust collector if used.
- Turn off the valve on the propane tank.

## 4.11 Emergency stop

Only use the emergency stop button if there is an emergency.

## 4.12 Adjusting grinding speed

To engage the grinding lift the "Gas throttle knob" until it locks then turn the "Gas throttle" knob (2) counter clock wise to increase the grinding speed and clock wise to decrease it. See "1.2 Mechanical specifications" for the rotation speed range.

To get the machine in idle speed push down the "Gas throttle knob"

## 4.13 Safety off position

When working on the machine, either maintenance or tool change, the machine must be set to the "Safety off position". See "2.16 Definition of the "Safety off position"" for further information.

## 4.14 Grinding

Refer to "Grinding guide" for instructions and information about grinding.

## 4.15 Changing tools



Before changing tools, read “2.17 Safety regarding maintenance”.

This illustration shows how to change the tools.

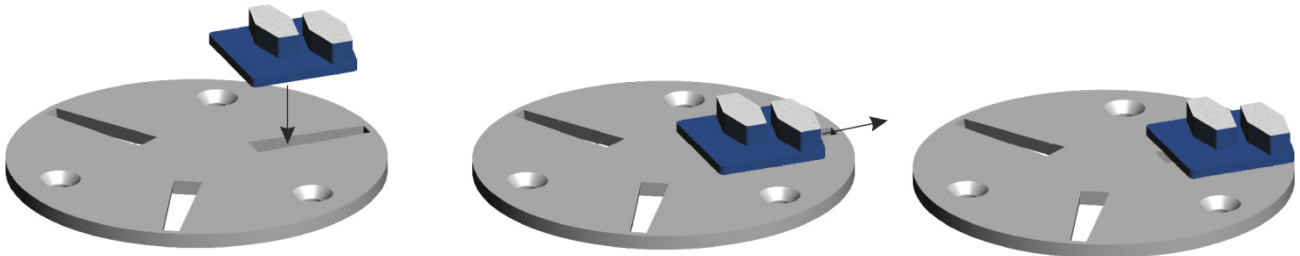

**Figure 4-7** How to fit the diamond segments on the Scan-On plate

- 1 Insert the segment at the widest part of the slot
- 2 Push the segment outwards
- 3 The segment is now fit on the Scan-On plate

To make sure that the segment is secured, use a small plastic hammer and slightly hit the segment outwards. In reverse this technique can be used to loosen segments that are stuck.

## 5 Maintenance

### 5.1 Precautions

Set the machine into the Safety off position before beginning any work on the machine.



See “2.16 Definition of the “Safety off position””.



Read “2.11 Electrical safety” before beginning any maintenance work.

All parts must have come to a complete stop before beginning any work!



*When the machine is lying down on its back it might tilt to it's upwards position. Take extra care to prevent this from happening to ensure that no injuries or damages occur.*



*When the machine has been operated the engine, segments, Scan-On plates and other parts on the gear barrel may be hot. Take extra care to prevent burn injuries.*

Adjustment, servicing and inspection work on the period of time limits, specified in this User Manual as well as any information on the replacement or parts and equipment must be undertaken and/or complied with!

These activities may only be undertaken by qualified personnel.

### 5.2 Daily inspection prior to operation

Inspect the following items prior to operation

- Inspect the wheels for damage.
- Inspect the grinding heads. Dirt between the Scan-On plate and the grinding hub can impair the flexibility of the grinding head.
- If any screws appears loose, tighten them.
- Check and add engine oil.
- Check for fuel and oil leakage.
- Check or clean air inlet screen.
- Look over the machine for any other damage.

### 5.3 Maintenance and inspection list

Daily	<ul style="list-style-type: none"> <li>▪ Inspect the wheels</li> <li>▪ Inspect the grinding heads</li> <li>▪ Check and add engine oil.</li> <li>▪ Check for fuel and oil leakage.</li> <li>▪ Check or clean air inlet screen.</li> <li>▪ Look for any other damage</li> </ul>
After first 8 hr.	<ul style="list-style-type: none"> <li>▪ Change engine oil</li> </ul>
Every 100 hr.	<ul style="list-style-type: none"> <li>▪ Change engine oil.</li> <li>▪ Check and clean oil cooler fins.</li> <li>▪ Clean and regap spark plugs.</li> </ul>
Every 200 hr.	<ul style="list-style-type: none"> <li>▪ Change oil filter.</li> <li>▪ Replace air cleaner primary element.</li> <li>▪ Check air cleaner secondary element.</li> </ul>
Every 300 hr.	<ul style="list-style-type: none"> <li>▪ Change grease on the gears above machine house.</li> </ul>
Every 300 hr.	<ul style="list-style-type: none"> <li>▪ Clean combustion chamber.*</li> <li>▪ Check and adjust valve clearance.*</li> <li>▪ Clean and lap valve seating surface.*</li> </ul>
Every 500 hr.	<ul style="list-style-type: none"> <li>▪ Replace air cleaner secondary element.</li> </ul>
12 hours after service	<ul style="list-style-type: none"> <li>▪ Tighten all screws</li> </ul>

Table 5-1 \*Recommended to be serviced by authorized Kawasaki dealer

Check the **Kawasaki Owner's Manual** for more detailed maintenance instructions.

### 5.4 Grinding disc replacement / assembly

Follow these steps to replace the Scan-On plate

- Make sure the machine is in its "Safety off position"
- Tilt the machine backwards and secure it.
- Remove any tools used.
- Loosen the three screws holding the Scan-On plate.
- Replace the Scan-On plate.
- It's recommended that new screws are used to fasten the replacement Scan-On plate.
- It's also recommended that copper paste is used on the surface of the screw hole at the Scan-On plate.
- Tighten all screws by hand and make sure that they are secured.

### 5.5 Cleaning the machine

Before starting to clean the machine, make sure it is in its "Safety off position"

Do not use highly pressurized water to clean the machine.  
Water and soap is recommended.

## 5.6 Trouble shooting

### 5.6.1 Troubleshooting

Symptom	Cause	Correction	A <sup>1</sup>
Starter motor does not operate	<ul style="list-style-type: none"> <li>▪ Weak or dead battery</li> <li>▪ Start key is faulty</li> <li>▪ For additional Causes</li> </ul>	<ul style="list-style-type: none"> <li>▪ Recharge or replace battery</li> <li>▪ Check and replace key/switch</li> <li>▪ See engine manual or dealer</li> </ul>	<ul style="list-style-type: none"> <li>○</li> <li>○</li> <li>○</li> </ul>
Engine turns over but does not start or run	<ul style="list-style-type: none"> <li>▪ Fuel tank not connected</li> <li>▪ Fuel tank empty</li> <li>▪ No fire at spark plug</li> <li>▪ Engine oil Pressure low</li> <li>▪ Oil Pressure Switch faulty</li> <li>▪ The emergency stop button is depressed</li> <li>▪ For additional causes</li> </ul>	<ul style="list-style-type: none"> <li>▪ Disconnect and reconnect tank</li> <li>▪ Refill or replace tank</li> <li>▪ Replace Spark plug</li> <li>▪ Check and fill Oil to correct level</li> <li>▪ Check and replace oil pressure switch</li> <li>▪ Release the emergency stop button.</li> <li>▪ See Engine manual or dealer</li> </ul>	<ul style="list-style-type: none"> <li>○</li> <li>○</li> <li>○</li> <li>○</li> <li>○</li> <li>○</li> <li>○</li> </ul>
Engine runs with loss of power or excessive exhaust fumes	<ul style="list-style-type: none"> <li>▪ Restriction in Air cleaner</li> <li>▪ Ignition System Misfire</li> <li>▪ Poor compression or timing</li> </ul>	<ul style="list-style-type: none"> <li>▪ Service air cleaner</li> <li>▪ Check or replace ignition coils</li> <li>▪ See engine manual or dealer</li> </ul>	<ul style="list-style-type: none"> <li>○</li> <li>○</li> <li>○</li> </ul>
Engine running hot or over heating	<ul style="list-style-type: none"> <li>▪ Intake screen or bonnet filter clogged</li> <li>▪ Cooling Fins Clogged</li> </ul>	<ul style="list-style-type: none"> <li>▪ Clean Screen and or bonnet filter</li> <li>▪ See engine manual for cleaning</li> </ul>	<ul style="list-style-type: none"> <li>○</li> <li>○</li> </ul>
High Oil consumption	<ul style="list-style-type: none"> <li>▪ Numerous causes</li> </ul>	<ul style="list-style-type: none"> <li>▪ See engine manual or dealer</li> </ul>	<ul style="list-style-type: none"> <li>○</li> </ul>
Engine Knocks and other engine noises	<ul style="list-style-type: none"> <li>▪ Numerous causes</li> </ul>	<ul style="list-style-type: none"> <li>▪ See engine manual or dealer</li> </ul>	<ul style="list-style-type: none"> <li>○</li> </ul>
The machine vibrates a lot	<ul style="list-style-type: none"> <li>▪ The grinding speed is to high</li> </ul>	<ul style="list-style-type: none"> <li>▪ Lower the speed</li> </ul>	<ul style="list-style-type: none"> <li>○</li> </ul>
	<ul style="list-style-type: none"> <li>▪ The tools are damaged</li> </ul>	<ul style="list-style-type: none"> <li>▪ Inspect the tools</li> <li>▪ Change the tools if needed</li> </ul>	<ul style="list-style-type: none"> <li>○</li> <li>○</li> </ul>

**Table 5-1**Troubleshooting

<sup>1</sup> See access t”



## 6 Spare Parts

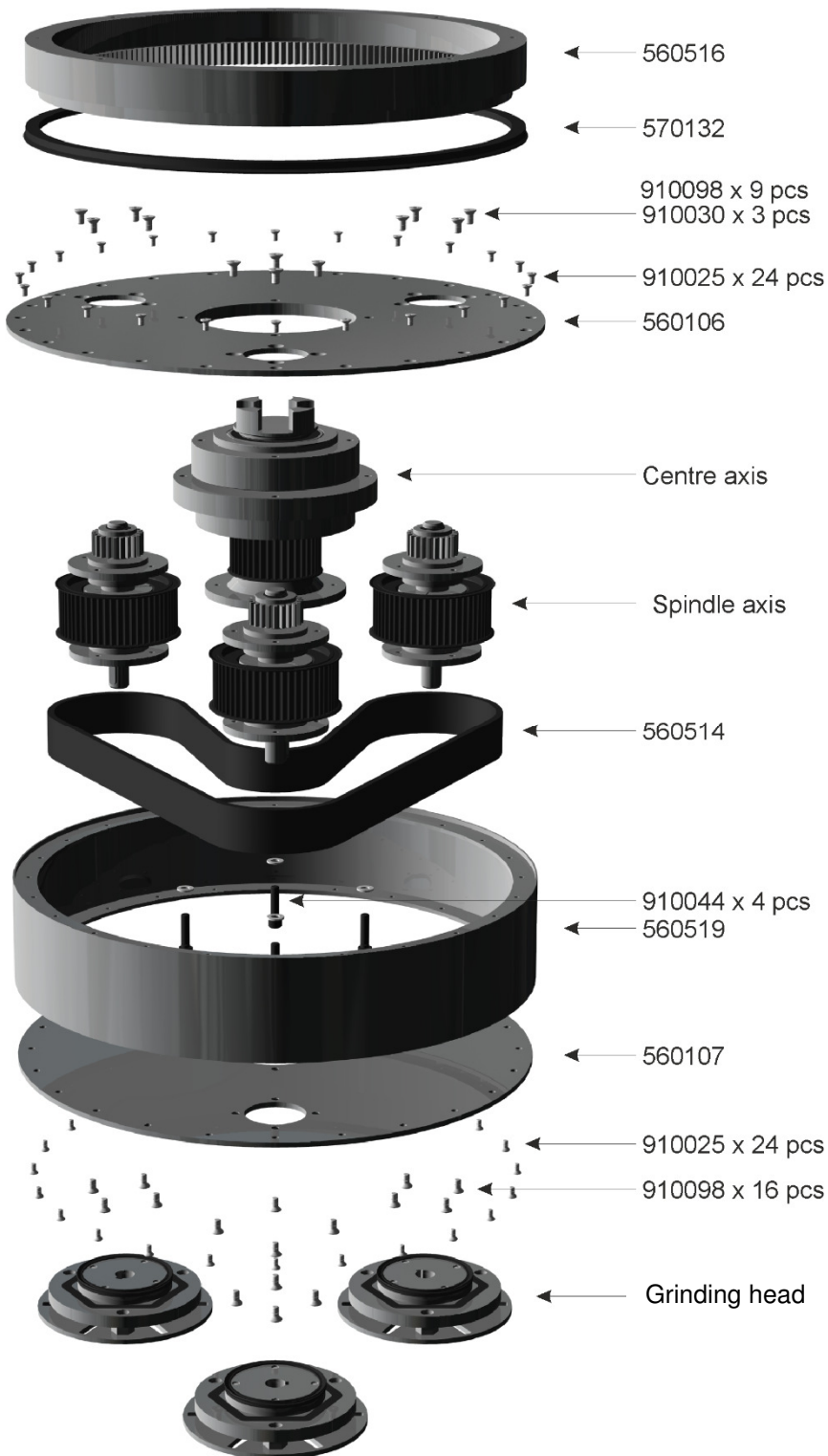



## 6.1 Center axis

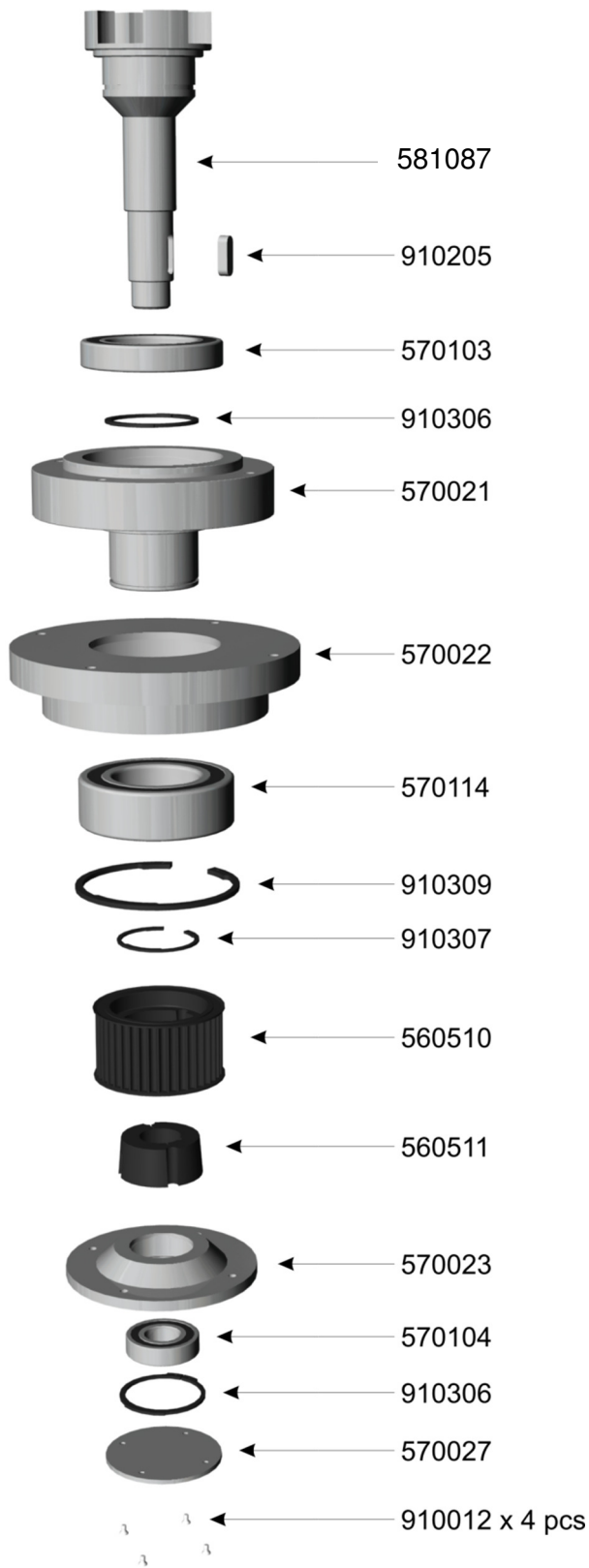

## 6.2 Grining spindle

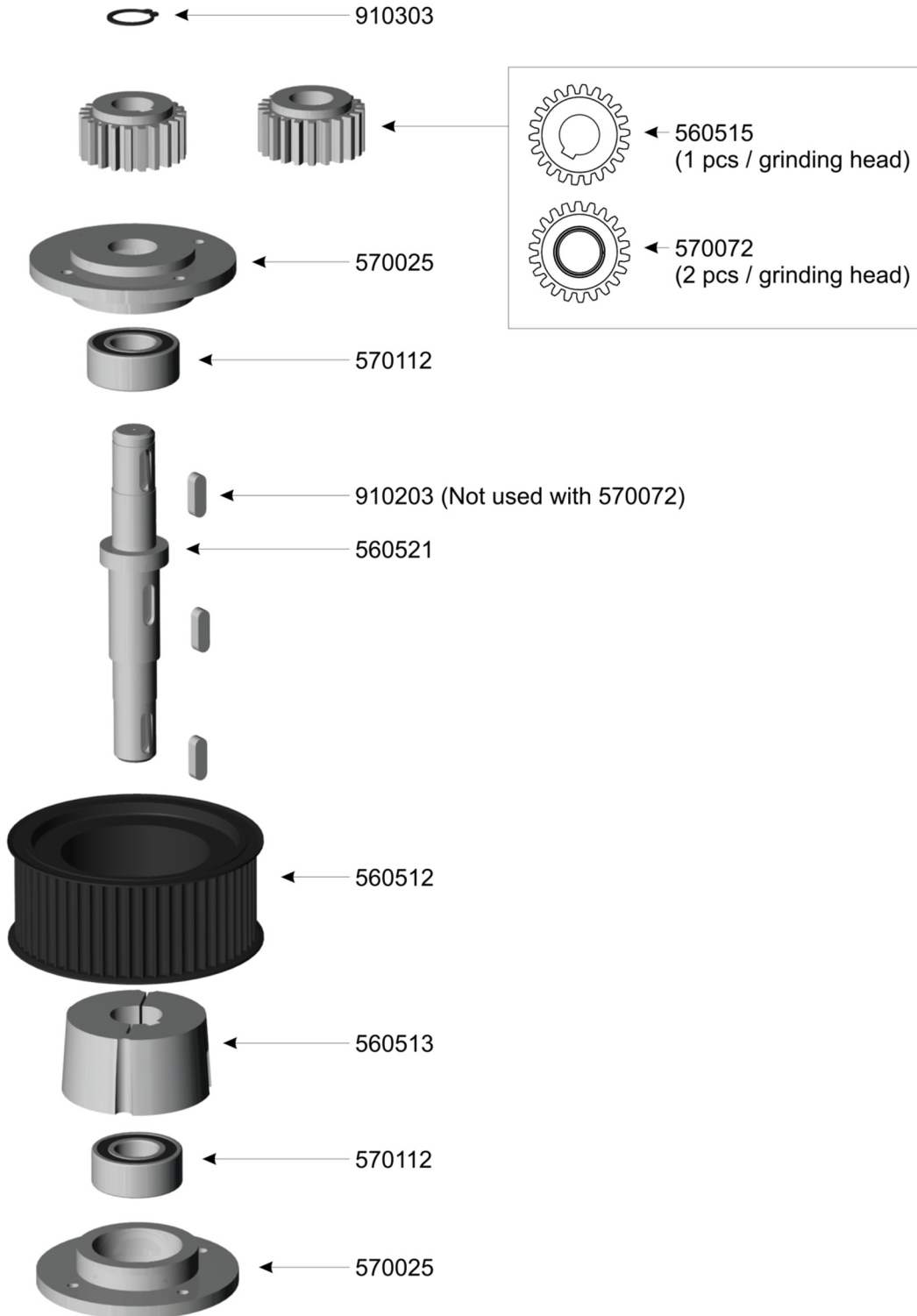
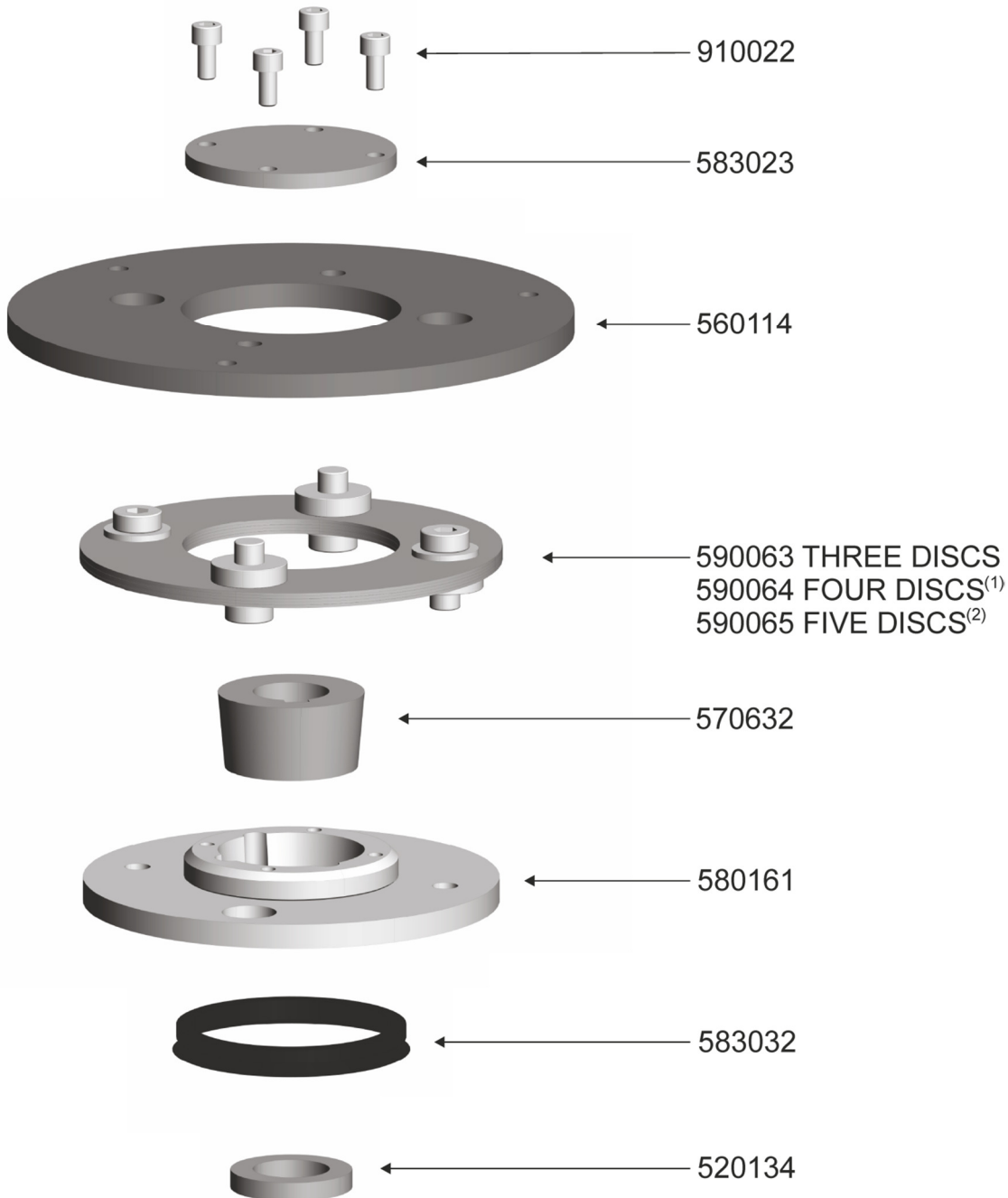

Figure 6.2 Grinding spindle

## 6.3 Grinding head



(1) Standard SC-650  
(2) Standard SC-700

## 6.1 Reduction

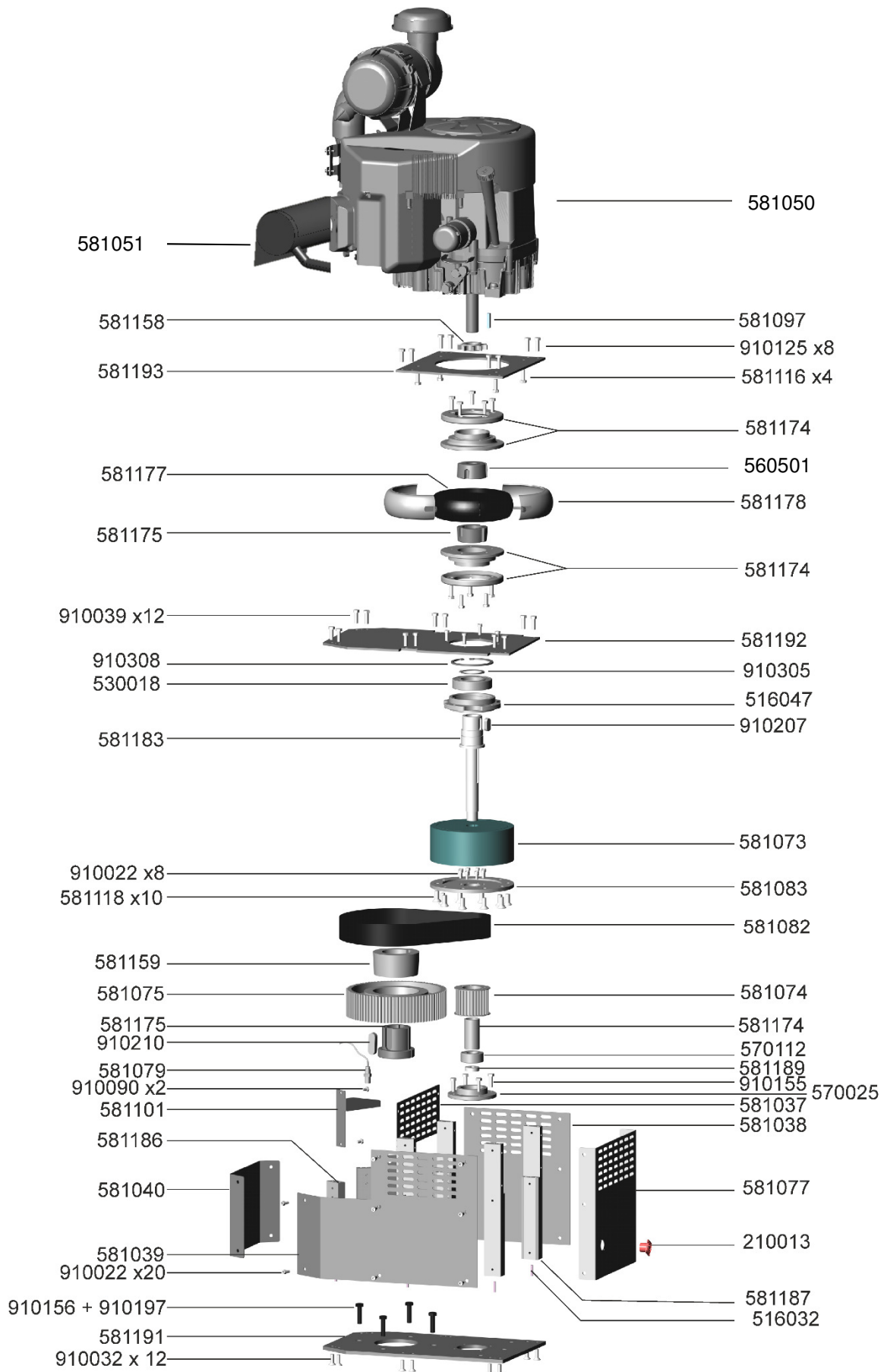

## 7 Warranty

This product from Scanmaskin Sweden AB comes with a twelve month warranty. If the product does not function satisfactorily during this period, Scanmaskin will return the product to full working order for normal use which the product is intended for – with no charge for labour or spare parts, according to the following conditions:

1. The warranty only applies to persons that have legal right to the equipment during the warranty period.
2. The manufacturer's undertaking is limited to the repair of defective parts or the replacement of these according to the manufacturer's assessment. Costs and risks for transport as well as dismantling and reinstallation of the product / products and other direct or indirect costs, associated with the repair in question, are not covered by this warranty.
3. Periodic inspections, adjustments, maintenance work and changes are not covered by the warranty.
4. Scanmaskin is not liable for any damages to grinding discs or other similar equipment.
5. The warranty only applies to material and design deficiencies and does not apply in the following cases:
  - a. Damage caused through accidents, carelessness, changes, use of spare parts or grinding tools that are not original components, or incorrect use and installation.
  - b. Damage caused by lightning, water, fire, vandalism, incorrect mains voltage, incorrect ventilation or other causes that lie outside of the manufacturer's control.
6. Scanmaskin reserves the right to modify the design – or make improvements without obligation to change previously manufactured products.
7. Scanmaskin reserves the right to modify the design – or make improvements without obligation to change previously manufactured products.
8. All warranty repairs must be carried out by Scanmaskin or by a Scanmaskin accredited repair workshop. Costs for repairs, carried out by an unauthorised workshop, will not be reimbursed by Scanmaskin. If such repairs damage this product these are not cover by the warranty agreement.

## 8 EU Declaration

### Declaration of conformity CE

<b><u>Manufacturer</u></b>	Scanmaskin Sweden AB
<b>Address</b>	Heljesvägen 10 437 36Lindome Sweden
<b><u>Product</u></b>	Grinding machine
<b>Name</b>	ScanCombiflex 650 PROPANE
<b>Serialnumber</b>	_____
<b><u>Standards used including number</u></b>	
<b>Machine directives</b>	2006/42/EG
<b>EMC</b>	2004/108/EC
<b>LVD</b>	2006/95/EG
<b>Harmonized standards</b>	
Safetyofmachinery	EN ISO 12100:2010
Safetyofmachinery	EN ISO 60204-1
Safe Torque Off	EN 61800-5-2
<b><u>Place of issue</u></b>	Lindome / Gothenburg / Sweden
<b><u>Name of authorized representative</u></b>	Claes-Göran Bergstrand
<b>Position</b>	Managing Director

### Declaration

We declare that as the authorized representative, the above information in relation to the supply / manufacture of this product is in conformity with the stated standards and other related documents following the provisions of EEC directives.

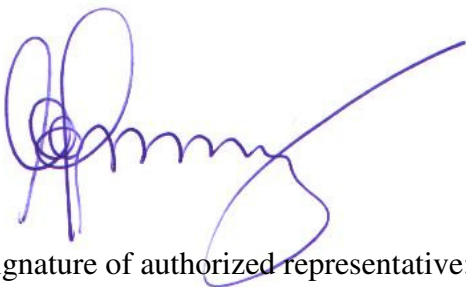

Signature of authorized representative:

## 9 Alphabetical reference

<b>A</b>	
Application	
range of.....	5
typical .....	5
<b>C</b>	
Cleaning .....	26
Contact information.....	38
Control panel .....	20
<b>E</b>	
EU Declaration.....	36
<b>G</b>	
Grinding disc	
Replacement .....	26
<b>M</b>	
Maintenance	
Daily .....	25
Inspection list .....	26
Precautions .....	25
<b>O</b>	
Operation.....	18
Options	
Water connection.....	3
<b>P</b>	
Power	
choice.....	2
inlet.....	2
source .....	2
<b>S</b>	
Spare Parts.....	28
Specifications	
Electrical.....	2
<b>T</b>	
Tools	
Availble tools .....	4
changing .....	24
Snap-On.....	24
Transport .....	17
lifting .....	17
manual .....	17
<b>V,W</b>	
Warranty.....	35

## 10 Contact information

### Sweden (Head Office)

Heljesvägen 10  
Box 187  
SE-437 22 Lindome

Phone: +46 (0) 31 99 49 70  
Fax: +46 (0) 31 99 48 70  
E-mail: [info@scanmaskin.se](mailto:info@scanmaskin.se)  
Website: [www.scanmaskin.se](http://www.scanmaskin.se)

### Denmark

Torvegade 22  
DK-7330 Brande

Phone: +45 97 18 00 58  
Fax: +45 97 18 45 58  
E-mail: [info@scanmineral.dk](mailto:info@scanmineral.dk)  
Website: [www.scanmaskin.se](http://www.scanmaskin.se)

### Norway

Maridalsveien 91  
N-0461 Oslo

Phone: +47 63 87 60 00  
Fax: +47 63 87 60 01  
E-mail: [info@scanmaskin.no](mailto:info@scanmaskin.no)  
Website: [www.scanmaskin.no](http://www.scanmaskin.no)

### Finland

Raudoittajantie 3 A  
FIN-06450 Porvoo / Borgå

Phone: +358 10 292 4700  
E-mail: [info@scanmaskin.fi](mailto:info@scanmaskin.fi)  
Website: [www.scanmaskin.fi](http://www.scanmaskin.fi)

### USA

C/O Jon Don Inc.  
4111 Airport Way South  
Seattle, WA 98108

Phone: +1 425 628 12 12  
E-mail: [info@scanmaskin.com](mailto:info@scanmaskin.com)  
Website: [www.scanmaskin.com](http://www.scanmaskin.com)