

EZ SPOT EXTRACTOR

By Jon-Don, Inc.

Please fill out the following information:

Model No: _____

Serial No: _____

Distributor Name: _____

Distributor Phone No: _____

Date of Purchase: _____



Jon-Don

400 Medinah Road, Roselle, IL 60172
Phone: 800-556-6366 | Fax: 888-344-6878
www.jondon.com

SAFETY, OPERATION AND MAINTENANCE MANUAL WITH PARTS LIST

Please read before use!

100 CFM, 804 WATT MOTOR



Model No. PM-EZS-EA

Jon-Don

IMPORTANT INFORMATION AND SAFETY INSTRUCTIONS

Register your Machine at www.jondon.com
Serial No: _____

EZ SPOT EXTRACTOR

Reliable Power

Fastest Pick-Up

Safe & Easy to Use

Innovative Design

Super Lightweight

Patented Features

Jon-Don

Dear Valued Customer,

Congratulations on the purchase of your 3-Gallon Spot Extractor carpet and upholstery machine! The world of carpet cleaning is becoming more high-tech and competitive and we strive to provide you with the most innovative products. Our Spot Extractor is yet another example of this, bringing a new dimension to carpet and upholstery cleaning with its cutting-edge features, quality and value.

Please review this manual, paying careful attention to the Safety Instructions section. Keep in mind that any unnecessary damage, neglect or abuse of this machine will void your warranty. You can be confident that simple maintenance will ensure that your Spot Extractor provides quality performance for many years to come.

If warranty questions arise, please consult your manual or contact your distributor. Should you have any questions regarding maintenance, replacing parts or ordering parts, please call an authorized distributor.

Before you begin using your Spot Extractor, thoroughly review the Owner's Manual.

Again, congratulations on the purchase of your 3-Gallon Spot Extractor carpet and upholstery machine!

8.0 Wiring Diagram

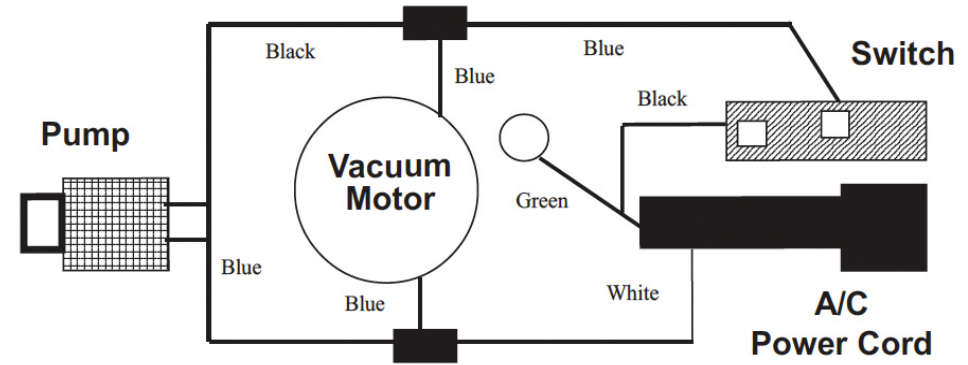

CAUTION – Electrical wire colors may vary. Determine start and end point of each wire to confirm connection point.

9.0 Problem Solving

Never operate this spot extractor when the equipment is not performing as expected or when any part is visibly damaged. When repair is needed, take the equipment to an authorized service center.

Spotter will not run

- Check power connection. Move the grounded plug to an outlet that is working. Verify that the plug is working by plugging in another electrical component such as lamp, hair dryer or drill.
- Inspect the power cord for damage.

Loss of vacuum

- Make sure the float is at the bottom of the unit. Open the screw cap and push the float down.
- Check that the hose cuff is securely attached to the front of the extractor.

Loss of solution pressure

- Verify that the pump is on. Remove jet from end of hand tool and press trigger on wand.
- Clean the solution intake in the solution tank. Check quick-disconnect for debris.
- If pump is still not working, seek authorized repair services.

7.0 Hoses and Hand Tool Drawing and Parts List

Schematic Drawing

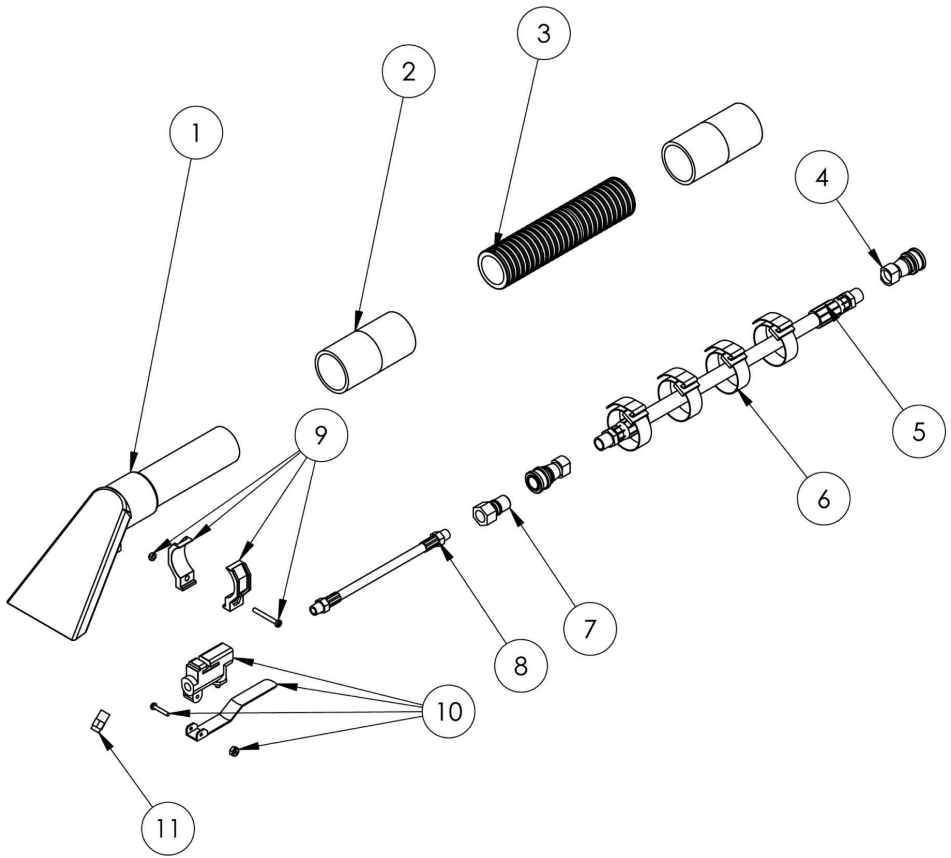

Table of Contents

- New Equipment Warranty4
- Returned Material Authorization (RMA) Procedure5
- 1.0 Safety Instructions5
- 2.0 Set-Up / Prepare Unit for Use5
- 3.0 Maintenance6
- 4.0 Grounding Instructions7
- 5.0 Machine Schematic Drawing8
- 6.0 Machine Parts List.9
- 7.0 Hoses and Hand Tool Drawing and Parts List10
- 8.0 Wiring Diagram.11
- 9.0 Problem Solving.....11

Parts List

Drawing No.	Item No.	Item Description	Qty. Needed
1	10-0505	4" Stainless Steel Hand Tool with Clear View Head	1.00
2	10-0463	Black Slip Hose Cuff for Spotter	2.00
3	50-1007	7-Foot Black Hose for Spotter	1.00
4	10-0474	1/8" Female QD for Spotter	1.00
5	10-0475	Solution Hose for Spotter	1.00
6	10-0388	Velcro Strap	1.00
7	10-0402	1/8" Male QD for Stainless Steel Hand Tool	1.00
8	10-0403	1/8" Brass Female Coupler	1.00
9	10-0506	Valve Clamp for Stainless Steel Hand Tool	1.00
10	10-0504	Valve for Stainless Steel Hand Tool	1.00
11	10-0502	Jet for Stainless Steel Hand tool	1.00

New Equipment Warranty

Lifetime on roto-molded body, 5-years on vacuum motor, pump and all electrical parts.

Warranty Policy

All equipment is inspected and tested before shipping from the manufacturer. All parts are warranted to be new and free from defects in workmanship and material, under normal use to the original retail purchaser. This warranty limits manufacturer's liability for defects in workmanship or materials for replacement of defective parts only. The manufacturer accepts no liability for incidental or consequential damages arisen from the use of any equipment, defective or not. This warranty is in lieu of all expressed or implied warranties and is extended only to the original retail purchaser. Manufacturer sales and service representatives are not authorized to waive or alter the terms of this warranty, or to increase the obligations of the manufacturer under the warranty. Parts replaced or repaired under this warranty are warranted for the remainder of the original warranty period.

Labor is only provided by authorized service centers. If an authorized service center is not near you, it is the purchaser's responsibility to take their machine to an authorized service center.

The manufacturer covers up to one (1) year (365 days) of service labor at the manufacturer's calculated hourly labor rate/repair time when performed by a manufacturer-authorized service provider. Ultimately, labor reimbursement costs are at the discretion of the manufacturer. At no time is the manufacturer responsible for travel time to complete on-call repairs. After one (1) year, the original retail purchaser is responsible for all labor costs with no manufacturer reimbursement.

The manufacturer charges a 25% restocking fee for any items that are being returned to stock. Items must be new, unused, free of damage and are only good for up to 30 days. After 30 days, the manufacturer does not accept the return of any items for a store credit.

Authorized warranty replacement parts need to come directly from the manufacturer. Any use of any other parts will void warranty. The manufacturer and Jon-Don, Inc. do not reimburse for parts used by the client that were not supplied directly for the machine under warranty.

The client must contact the manufacturer prior to working on or changing out of any parts, etc. The manufacturer must issue an RMA Sheet containing approved labor time and replacement parts. Do not send parts or equipment back to the manufacturer without an RMA Number and approval. A copy of the RMA Sheet must be enclosed in the box with the returned item. No returns shall be authorized unless the proper RMA procedures are followed. It is the responsibility of the distributor to repair the client's equipment as soon as possible.

No labor will be paid for, nor parts cost paid for or reimbursed, that have not previously been approved by the manufacturer. All warranty work must be approved and authorized to qualify, and appropriate warranty procedures must be followed.

The warranty starts on the purchase date by the original purchaser from an authorized Jon-Don, Inc. distributor, subject to proof of purchase. The Machine Registration Form must be completed and sent to the original manufacturer at the time of purchase. If proof of purchase cannot be identified, the warranty start date is ninety (90) days after the date of sale to an authorized Jon-Don, Inc. distributor.

(4) 3-Gallon EZ Spot Extractor

6.0 Machine Parts List

Drawing No.	Item ID	Item Description	Qty. Needed
1	SP-3-ST-BLKGRAN	Black Granite 3-Gallon Solution Tank	1.00
2	SP-3-R-BLUGRAN	3-Gallon Recovery Tank - Blue Granite	1.00
3	10-0383	6-32 x 1/4" Phil Pan Screw	6.00
4	10-0400-D	Latch for Sniper	1.00
5	10-0412	C-Channel for Spotter Handle	2.00
6	10-0414	Rivet for Spotter Handle	4.00
7	10-0384	.125 Thick Nylon Washer	4.00
8	10-0385	.06 Thick Nylon Washer	4.00
9	10-0074	Flat Washer #8 SAE	5.00
10	10-0216	Allen Head Screw for Backpack	4.00
11	10-0379	8-32 x 3/8" Screw	4.00
12	10-0405	1-1/2" PVC SCH40 Slip Thread	1.00
13	10-0302-A	Hatch Cover Gasket for Spotter	1.00
14	10-0416-A	1-1/2" Black ABS Stand Pipe	0.60
15	10-0304	Spotter Cap and Float Assembly	1.00
16	10-0419	Screw for Spotter Hatch	6.00
17	SP-3-H-BLK	3-Gallon Spotter Black Handle	1.00
18	10-0406	Nylon Barb 90 1/8" NPT 1/4"	2.00
19	80-0017-2	Bulk Head fitting for Spotter	1.00
20	10-0403	1/8" Brass Female Coupler	1.00
21	10-0402	1/8" Male QD	1.00
22	10-0434	Threaded Hose for Spotter	2.50
23	10-0407	1/8" Strait Nylon Barb NPT	4.00
24	10-0845-2	1/8" Strainer for Spotter	1.00
25	10-0300	55 psi Pump for Spotter	1.00
26	10-0301	L Bracket for Spotter	1.00
27	10-0435	Oetiker Clamp	4.00
28	10-0303	Roller Blade Wheel for Spotter	2.00
29	10-0387	5/16" x 1" Spotter Wheel Bolt	2.00
30	10-0022	Shoulder and Waist Belt Screw	1.00
31	10-0017	Deflector Screw	1.00
32	10-1028	Bottom Base Plate for Spotter	1.00
33	10-0492	Screw for Plates on Spotter	2.00
34	10-0014	Motor Screw	2.00
35	10-0380	10-32 x 3/8" Screw	2.00
36	10-1024	Motor Mount Plate for Spotter	1.00
37	10-0354	3-Gallon Spotter Motor	1.00
38	10-0386	Stamped Motor Screen	1.00
39	10-1030	Spotter Motor Gasket	1.00
40	10-0027-A	Strain Relief Nut	1.00
41	10-1026	Switch Plate for 3-Gallon w/ Heat	1.00
42	10-0027	Pigtail Strain Relief	1.00
43	10-0448	20-Foot Spotter Cord	1.00
44	10-0025	On/Off Switch	2.00
45	10-0400-C	Keeper Latch for Spotter	1.00

3-Gallon EZ Spot Extractor (9)

5.0 Machine Schematic Drawing

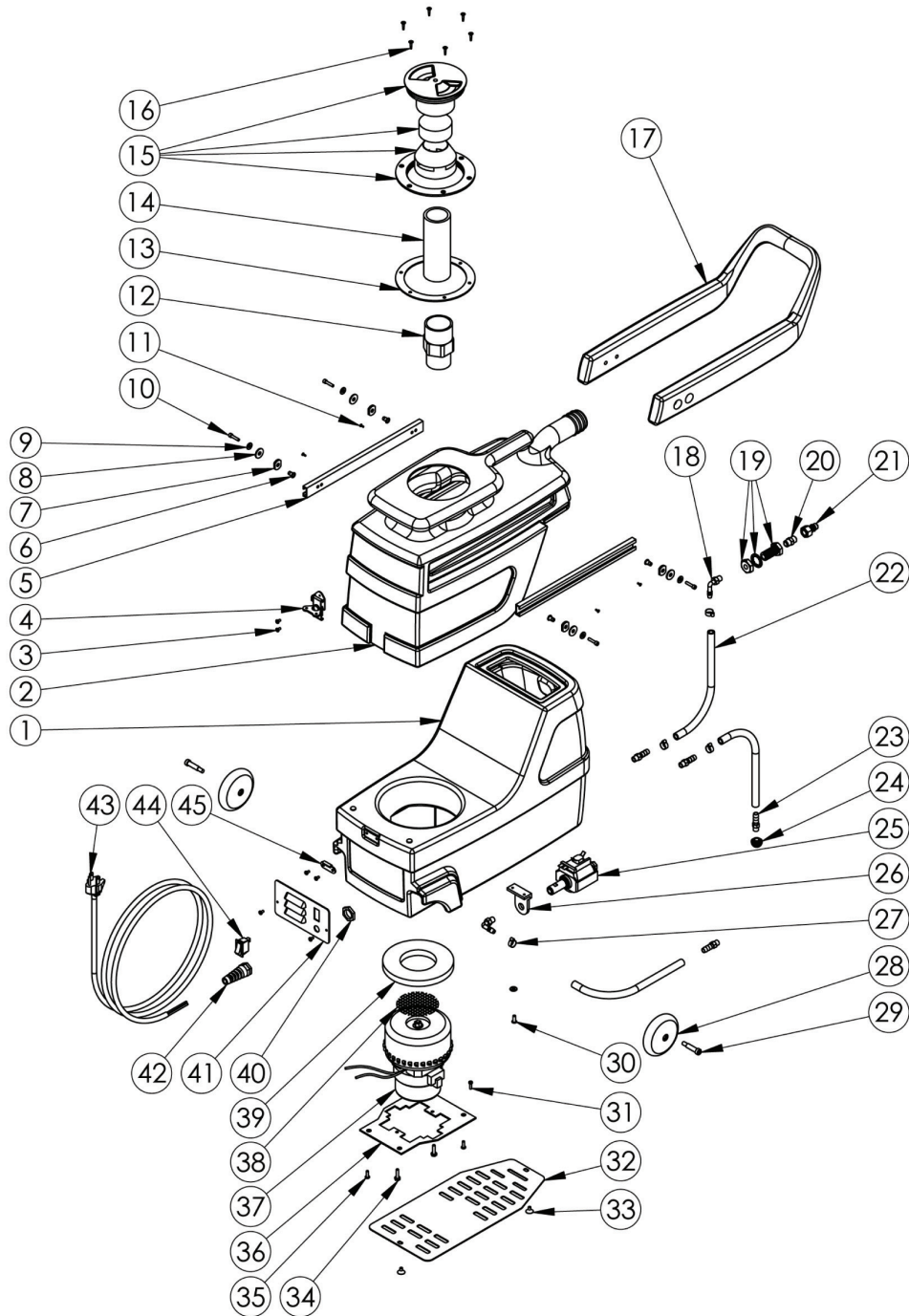

Returned Material Authorization (RMA) Procedure

Original purchaser (distributor/service center) must contact the manufacturer to follow correct RMA/warranty procedures. Must include a copy of RMA Sheet enclosed in the box with returned item. No returns shall be authorized unless proper RMA procedures are followed. It is the responsibility of the distributor to repair the client's equipment as soon as possible. Labor is only provided by authorized service centers. If an authorized service center is not near you, it is the purchaser's responsibility to take their machine to an authorized service center.

Client must contact the distributor prior to working on or changing out any parts, etc. Manufacturer must issue an RMA Sheet containing approved labor time and replacement parts. Do not send parts or equipment back to manufacturer without an RMA number and approval. No labor will be paid for, nor part costs paid for or reimbursed that have not been previously approved by the manufacturer. All warranty work must be approved and authorized to qualify and appropriate warranty procedures must be followed.

1.0 Safety Instructions

WARNING: PLEASE READ AND SAVE! FOLLOW THESE PRECAUTIONS WHEN USING YOUR SPOT EXTRACTOR.

- DO NOT operate this unit if any part of the unit appears to be damaged.
- DO NOT operate if ground plug is broken.
- DO NOT operate if the unit is in standing water.
- DO NOT use volatile substances or operate where volatile substances exist.
- DO NOT service while unit is running or connected to electricity. Unplug the unit!
- DO NOT use water more than 120 degrees Fahrenheit.
- DO NOT use solvents with this unit.
- DO NOT use as a dry vacuum.
- DO NOT use unit unless completely assembled.
- Use only liquid detergents. Powders do not fully dissolve and damage motor.
- Always use defoamer. Foam will suspend moisture particles that damage motor.

2.0 Set-Up / Prepare Unit for Use

DO NOT EXPOSE TO RAIN. STORE INDOORS.

- All spot extractors – no matter what the time of year – are shipped with antifreeze in the pump and solution lines. Prior to first use, fill the tank with one quart of warm water. Attach the hose and using the hand tool, flush out the system by spraying the one quart of water through the pump.
- Attach the 1-1/2 inch vacuum hose and the brass quick disconnect.
- Fill the base unit (the recovery tank must be removed) with warm water (less than 100 degrees Fahrenheit). Fill to approximately 4 inches from the top. Use a liquid detergent made for carpet cleaning or upholstery. Read and mix to the dilution ratios as directed.

2.0 Set-Up / Prepare Unit for Use Continued

- NEVER run the vacuum only with the pump on for more than 3 minutes. Water/solution needs to run through pump at all times to keep the pump cool while in use. Failure to do so will void the warranty.
- Be sure to replace any filters back into the machine prior to use.
- Do not use citrus acid, buterol or harsh degreasers inside the machine.

Vacuum Shut-Off

The spot extractor is designed with a vacuum restrictor to reduce the vacuum when the recovery tank is full. When the vacuum is restricted, the liquid will not travel up the nozzle of the hand tool. The motor speeds up (the sound of the motor will change) and this is your warning to dispose of recovered solution. The restrictor is a foam float that slides up and down the vacuum tube in the recovery tank as shown in the photo to the right.



3.0 Maintenance

Following Each Use

Remove the vacuum hose from the upper body, un-clip, rotate latch on the back of the unit and remove the upper section of the spotter. Dispose of the used solution by pouring the solution out of the vacuum inlet (not the hatch cover) into the toilet or janitor's closet sink.



IMPORTANT!! Be sure to thoroughly drain water out of heater lines prior to storage in colder climates. This heater will freeze and possibly crack, voiding your warranty.

Prevent Mineral Deposit Build-Up

Vinegar may be used to prevent mineral deposit build-up in your machine's lines and pump. Failure to do so may clog your lines and pump. Every two weeks, pour vinegar into the solution tank (dilute with 1/2 water). Run the pump, while squeezing your wand or upholstery tool's trigger unit you smell vinegar or notice it coming out of the tool. Let the machine sit overnight, and no longer, with the vinegar in its lines. The next day, flush the machine with 1-gallon of clean water or until you do not smell vinegar any longer.

PLEASE NOTE: If you choose to use CLR, follow the directions on the bottle. **DO NOT** leave CLR in the machine's lines and flush thoroughly. CLR may corrode the machine's components and **VOID** your warranty. If you choose to use vinegar, **MUST** dilute with 1/2 water. Failure to do so may damage the machine's components and **VOID** your warranty.

4.0 Grounding Instructions

DANGER: IMPROPER GROUNDING METHOD CAN RESULT IN A RISK OF ELECTRIC SHOCK.

Electrical equipment must be grounded. If the machine should malfunction or breakdown, grounding provides a path of least resistance for electrical current to reduce the risk of electric shock. The spot extractor is equipped with a cord containing a grounding conductor and grounding plug. The plug must be inserted into an appropriate outlet that is properly installed and grounded in accordance with all local codes and ordinances.

If repair or replacement of the cord or plug is necessary, **DO NOT** connect the grounded wire to a flat bed terminal. The grounding wire is the wire with insulation and an outer green surface, with or without yellow stripes.

Grounding Method

The electric equipment is for use on a normal 120 volt circuit. It has a grounded plug that fits the outlet illustrated in Figure A. If a properly grounded outlet is not available, a temporary adapter, such as the adapter illustrated in Figure B and C, may be used to connect the plug into a 2-pole outlet, as shown in Figure C.

The temporary adapter should be used only until a properly grounded outlet, Figure A, can be installed by a qualified electrician. The green colored rigid ear lug or grounding means extending from the adapter must be connected to a permanent ground, such as a properly grounded outlet box cover. Whenever the adapter is used, it must be held in place by its grounding means and a metal screw, as shown in Figure C.

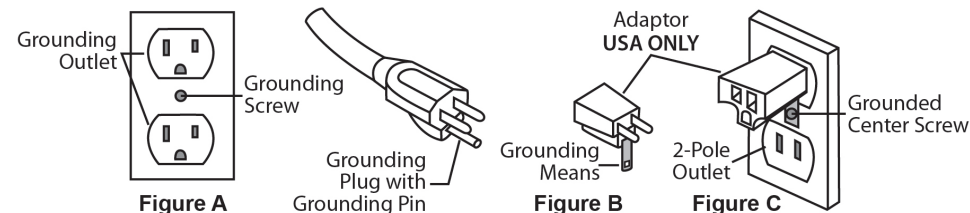

WARNING:

Improper connection of the equipment grounding conductor can result in a risk of electric shock. Check with a qualified electrician or service person if you are in doubt as to whether the outlet is properly grounded. **DO NOT** modify the plug provided with the equipment. If it will not fit into the outlet, have a proper outlet installed by a qualified electrician.

NOTE: In Canada, the use of a temporary adapter is not permitted by the Canadian Electrical Code.