

CENTURY 400 INC.

**CENTURY  
400**

## **PORTABLE EXTRACTOR**

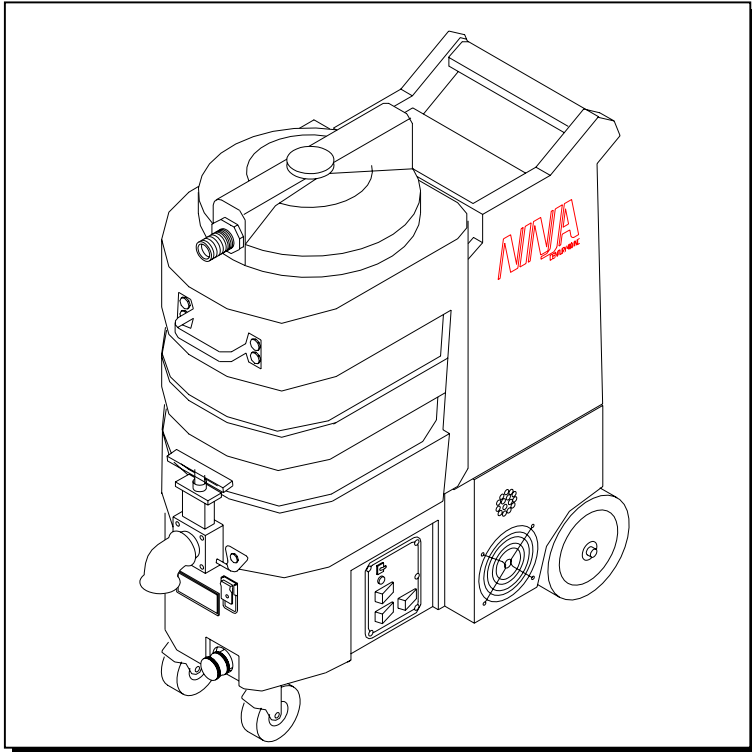

Operating Instructions

**MODELS:** 411-222MO  
411-225MO

---

*Read these instructions before using the machine*



## **MACHINE DATA LOG/OVERVIEW**

<b>MODEL</b>	_____
<b>DATE OF PURCHASE</b>	_____
<b>SERIAL NUMBER</b>	_____
<b>SALES REPRESENTATIVE #</b>	_____
<b>DEALER NAME</b>	_____
<b>OPERATIONS GUIDE NUMBER</b>	_____
<b>PUBLISHED</b>	_____

<b>YOUR DEALER</b>	
<b>Name:</b>	_____
<b>Address:</b>	_____
<b>Phone Number:</b>	_____

### **OVERVIEW**

The Ninja is an electric powered carpet extractor intended for commercial use. This appliance applies a cleaning solution to the carpet and then vacuums the soiled water back into the recovery tank.

# TABLE OF CONTENTS

<i>Machine Data Log/Overview</i> .....	2
<i>Table of Contents</i> .....	3

## HOW TO USE THIS MANUAL

<i>How to use this Manual</i> .....	1-1
-------------------------------------	-----

## SAFETY

<i>Important Safety Instructions</i> .....	2-1
<i>Hazard Intensity Level</i> .....	2-2
<i>Safety Label Location</i> .....	2-3
<i>Grounding Instructions</i> .....	2-4

## OPERATIONS

<i>Technical Specifications</i> .....	3-1
<i>Controls</i> .....	3-2
<i>Machine Operation</i> .....	3-3
<i>Pre-Run Machine Inspection</i> .....	3-3
<i>Equipment Set-up</i> .....	3-3
<i>Priming the Pump</i> .....	3-3
<i>Emptying &amp; Cleaning Tanks</i> .....	3-3

## MAINTENANCE

<i>Daily Maintenance</i> .....	4-1
<i>Periodic Maintenance</i> .....	4-1
<i>Monthly Maintenance</i> .....	4-1
<i>Semi-annually</i> .....	4-1
<i>Lubrication</i> .....	4-1
<i>Storage</i> .....	4-1
<i>Vacuum Motor Replacement</i> .....	4-2
<i>Solution Pump Replacement</i> .....	4-2
<i>Pump Replacement Kits</i> .....	4-3
<i>Pressure Regulator</i> .....	4-4
<i>Machine Troubleshooting</i> .....	4-5

## GROUP PARTS LIST

<i>Frame Group (200 psi)</i> .....	5-1
<i>Frame Group (500 psi)</i> .....	5-3
<i>Pump Group (200 psi)</i> .....	5-5
<i>Pump Group (500 psi)</i> .....	5-7
<i>Recovery and Solution Tank Group</i> .....	5-9
<i>Vacuum Motor Group</i> .....	5-11
<i>Wiring Group (200 psi)</i> .....	5-13
<i>Wiring Group (500 psi)</i> .....	5-14
<i>Warranty</i> .....	5-15

# HOW TO USE THIS MANUAL

This manual contains the following sections:

- HOW TO USE THIS MANUAL
- SAFETY
- OPERATIONS
- MAINTENANCE
- PARTS LIST

The HOW TO USE THIS MANUAL section will tell you how to find important information for ordering correct repair parts.

Parts may be ordered from authorized dealers. When placing an order for parts, the machine model and machine serial number are important. Refer to the MACHINE DATA box which is filled out during the installation of your machine. The MACHINE DATA box is located to the inside of the front cover of this manual.

MODEL _____
DATE OF PURCHASE _____
SERIAL NUMBER _____
SALES REPRESENTATIVE # _____
DEALER NAME _____
OPERATIONS GUIDE NUMBER _____
PUBLISHED _____

The model and serial number of your machine is on the front of the Frame.

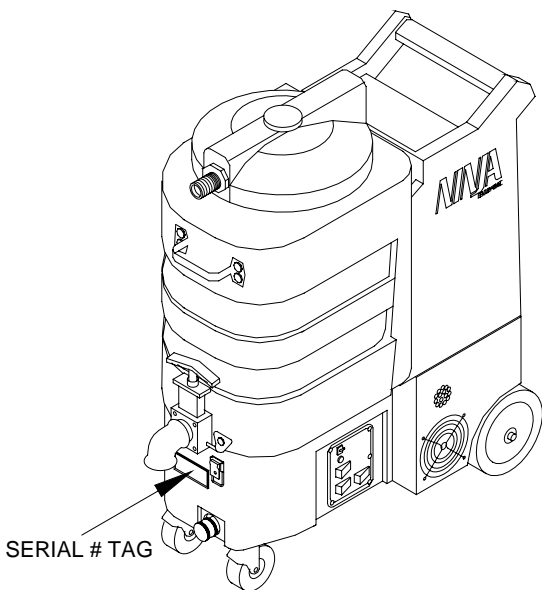

The SAFETY section contains important information regarding hazard or unsafe practices of the machine. Levels of hazards are identified that could result in product or personal injury, or severe injury resulting in death.

The OPERATIONS section is to familiarize the operator with the operation and function of the machine.

The MAINTENANCE section contains preventive maintenance to keep the machine and its components in good working condition. They are listed in this general order:

- Maintenance
- Lubrication
- Vacuum Motor Replacement
- Solution Pump Replacement
- Troubleshooting

The PARTS LIST section contains assembled parts illustrations and corresponding parts list. The parts lists include a number of columns of information:

- **REF** – column refers to the reference number on the parts illustration.
- **PART NO.** – column lists the part number for the part.
- **QTY** – column lists the quantity of the part used in that area of the machine.
- **DESCRIPTION** – column is a brief description of the part.
- **SERIAL NO. FROM** – column indicates the first machine the part number is applicable to. When the machine design has changed, this column will indicate serial number of applicable machine. The main illustration shows the most current design of the machine. The boxed illustrations show older designs.
- **NOTES** – column for information not noted by the other columns.

*NOTE: If a service or option kit is installed on your machine, be sure to keep the KIT INSTRUCTIONS which came with the kit. It contains replacement parts numbers needed for ordering future parts.*

## IMPORTANT SAFETY INSTRUCTIONS

**When using an electrical appliance, basic precaution must always be followed, including the following:**

**READ ALL INSTRUCTIONS BEFORE USING THIS MACHINE.**

**This machine is for commercial use.**



### **WARNING:**

**To reduce the risk of fire, electric shock, or injury:**

Connect to a **properly grounded outlet**. See Grounding Instructions.

**Do not** leave the machine unattended. Unplug machine from outlet when not in use and before maintenance or service.

**Use only** indoors. Do not use outdoors or expose to rain.

**Do not** allow machine to be used as a toy. **Close attention** is necessary when used by or near children.

**Use only** as described in this manual. Use only manufacturer's recommended components and attachments.

**Do not** use damaged electrical cord or plug. Follow all instructions in this manual concerning grounding the machine. If the machine is **not working properly**, has been dropped, damaged, left outdoors, or dropped into water, return it to an authorized service center.

**Do not** pull or carry machine by electrical cord, use as a handle, close a door on cord, or pull cord around sharp edges or corners.

**Do not** run machine over cord. **Keep** cord away from heated surfaces.

**Do not** unplug machine by pulling on cord. To unplug, grasp the electrical plug, not the electrical cord.

**Do not** handle the electrical plug or machine with wet hands.

**Do not** operate the machine with any openings blocked. Keep openings free of debris that may reduce airflow.

This machine is intended for cleaning carpet only.

**Do not** vacuum anything that is burning or smoking, such as cigarettes, matches, or hot ashes.

This machine is not suitable for picking up health endangering dust.

Turn off all controls before unplugging.

**Machine can cause a fire** when operating near flammable vapors or materials. Do not operate this machine near flammable fluids, dust or vapors.

**This machine is suitable for commercial use, for example in hotels, schools, hospitals, factories, shops and offices for more than normal housekeeping purposes.**

Maintenance and repairs must be done by qualified personnel.

If foam or liquid comes out of machine, switch off immediately.

## **SAVE THESE INSTRUCTIONS**

# SAFETY LABEL LOCATION

NOTE: These drawings indicate the location of safety labels on the machine. If at any time the labels become illegible, promptly replace them.

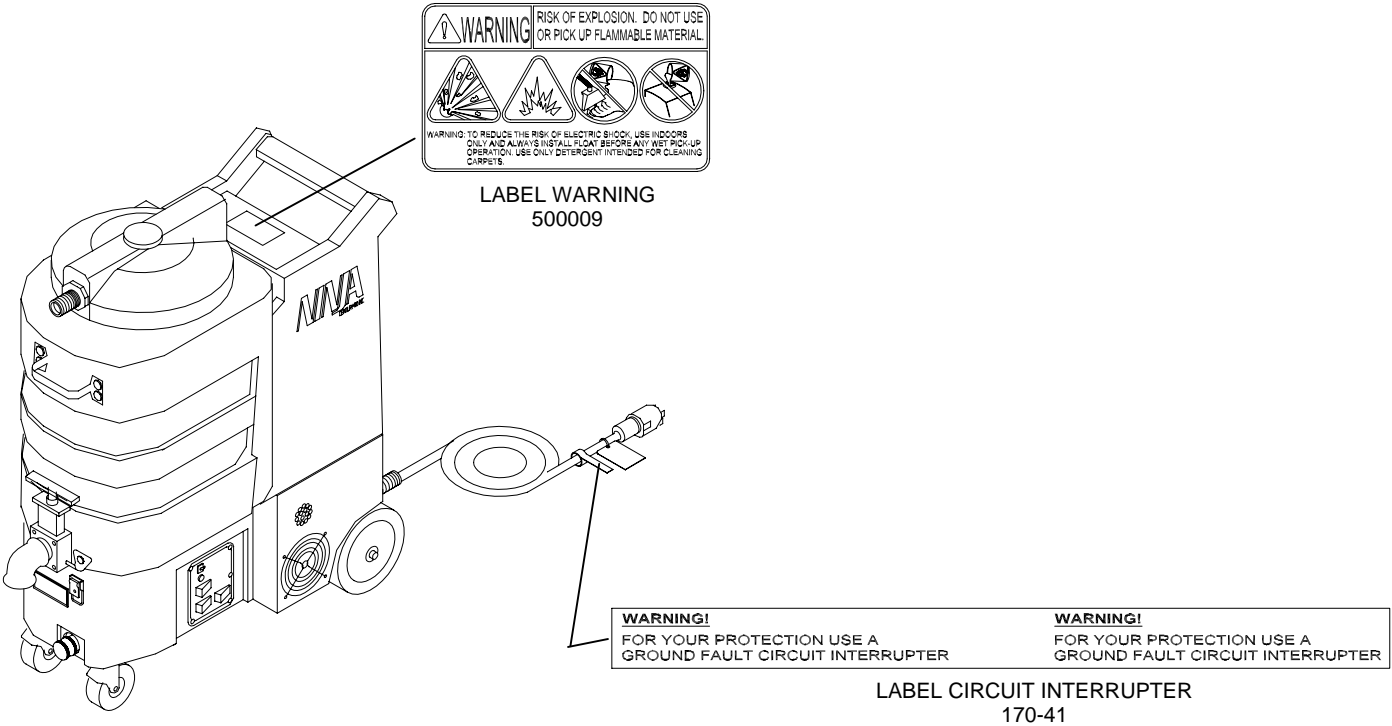

## GROUNDING INSTRUCTIONS

**THIS PRODUCT IS FOR COMMERCIAL USE ONLY.**

### ELECTRICAL:

In the USA, this machine operates on a standard 15 amp 115V, 60 hz, A.C. power circuit. The amp, hertz, and voltage are listed on the data label found on each machine. Using voltages above or below those indicated on the data label will cause serious damage to the motors.

### EXTENSION CORDS:

If an extension cord is used, the wire size must be at least one size larger than the power cord on the machine, and must be limited to 50 feet (15.5m) in length.

### GROUNDING INSTRUCTIONS:

This appliance must be grounded. If it should malfunction or break down, grounding provides a path of least resistance for electric current to reduce the risk of electric shock. This appliance is equipped with a cord having an equipment-grounding conductor and grounding plug. The plug must be inserted into an appropriate outlet that is properly installed and grounded in accordance with all local codes and ordinances.

This appliance is for use on a nominal 120-volt circuit, and has a grounded plug that looks like the plug in "Fig. A". A temporary adaptor that looks like the adaptor in "Fig. C" may be used to connect this plug to a 2-pole receptacle as shown in "Fig. B", if a properly grounded outlet is not available. The temporary adaptor should be used only until a properly grounded outlet (Fig. A) can be installed by a qualified electrician. The green colored rigid ear, lug, or wire extending from the adaptor must be connected to a permanent ground such as a properly grounded outlet box cover. Whenever the adaptor is used, it must be held in place by a metal screw.

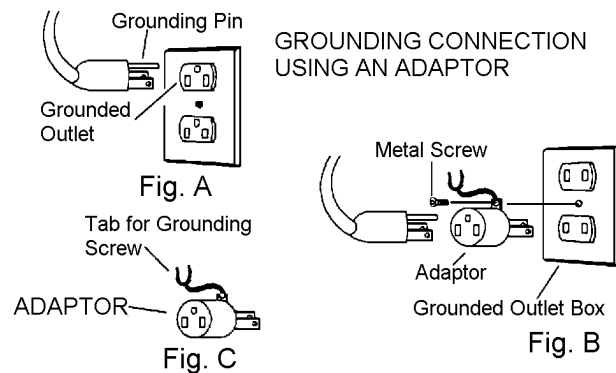

Note: Adaptors are not allowed in Canada.

**Improper connection of the equipment-grounding conductor can result in a risk of electric shock. Check with a qualified electrician or service person if you are in doubt as to whether the outlet is properly grounded. Do not modify the plug provided with the appliance - if it will not fit the outlet, have a proper outlet installed by a qualified electrician.**

## TECHNICAL SPECIFICATIONS

ITEM	MEASURE
ELECTRICAL	115 Volt, 60 hz
Vacuum Motor	Dual 2 stage
Solution Pump	200 psi
	500 psi
Solution Capacity	10 gal (38 L)
Recovery Capacity	8 gal (240 kg)
Weight- Empty	110 lbs (240 kg)
Weight-Full Solution	200 lbs (440 kg)
Height	36 inches (91.44 cm)
Length	29 inches (73.66 cm)
Width	19.5 inches (49.53 cm)
Power cord	22 feet (6.71 m)

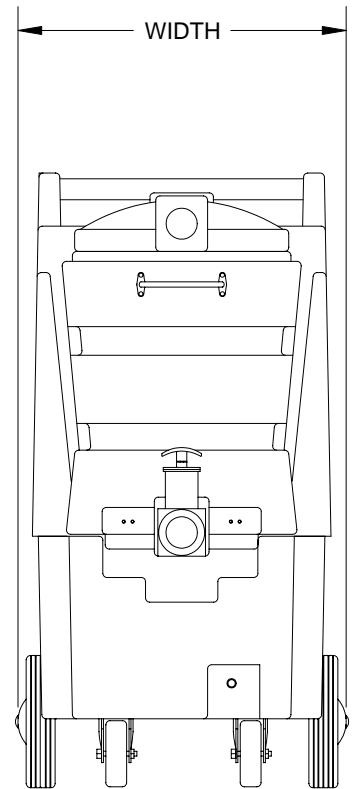
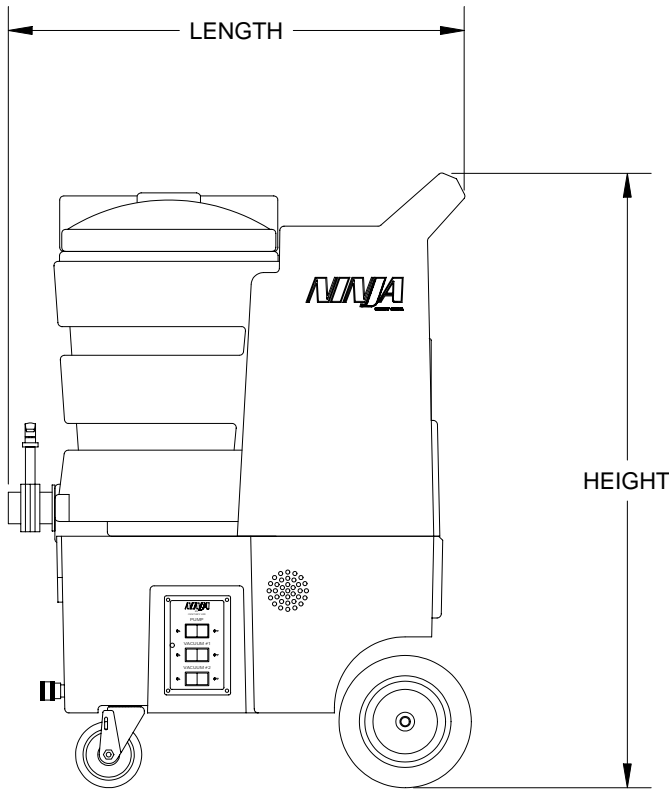



# CONTROLS

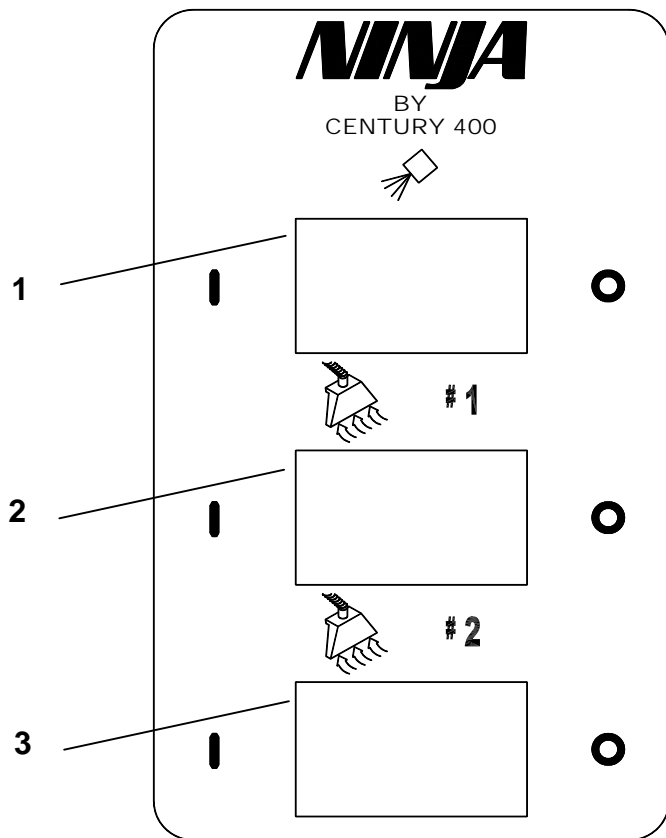

- 
1. Pump Switch
  2. Vacuum #1 Switch
  3. Vacuum #2 Switch

## PRE-RUN INSPECTION

1. Check all fittings and connectors for proper assembly.
2. Check all hoses for leaks. Repair or replace any damaged hoses.
3. Check power cord(s) for any damage. If damaged, replace.

## EQUIPMENT SET-UP

1. Plug power cord from machine into properly grounded wall outlet.
2. Turn vacuum motor switch on and off to make sure there is electrical power at machine.
3. Connect vac hose to machine. Slide the swivel cuff over the outlet on the tank.
4. Connect the hose to your machine and wand. Pull back the knurled collar on the quick disconnect coupler and push onto the connection on the chassis. To avoid leaks, check to be that a positive connection was made.
5. Using a clean container, fill the solution tank with clean hot water. Mix in a non-foaming cleaning concentrate for use in hot water extraction machines, following the manufacture's instructions printed on container.  
**NOTE:** When using a powder cleaner, pre-mix with hot water in a clean container before adding to the solution tank.
6. Turn pump and vacuum switch(s) to the on position.
7. Start cleaning.

## PRIMING THE PUMP [SELF PRIMING VALVE]

1. Turn pump and both vacuums on.
2. Press lever (located above the accessory connection; front of machine) toward machine.
3. Do this for 30 seconds or until there is a steady flow of water flowing through the sight tube (located on right side of recovery tank.)

## EMPTYING AND CLEANING

 **WARNING:** Always use defoamer if foaming occurs. Foam will suspend large particles that may damage vacuum(s) as well as allow liquid into the vacuum motor(s) without activating the float shutoff.

1. Before proceeding, make certain that the nozzle is functioning properly.
  - a. To check, hold the wand about one foot above the surface to be cleaned and open the wand valve. A full spray should be observed from the nozzle.
  - b. If the nozzle is not showing a full spray pattern, adjust nozzle for proper pattern, clean, or replace nozzle.
2. Normally, chemical is applied on the push stroke of the wand when cleaning. Vacuuming is done on the pull stroke. For heavily soiled carpets the wand may be used in a scrubbing manner, applying chemical in both the push and pull stroke.
3. When cleaning, keep the working opening (wand mouth) flat on the surface being cleaned. Keep the wand moving when the valve is open.
4. The shutoff float inside the vacuum tank will impede the vacuum flow when the vacuum tank is full. When this occurs, empty the vacuum tank by opening the dump valve and dispose of the waste in a proper manner.
5. Once the vacuum tank has been emptied, you may once again proceed with cleaning

# MAINTENANCE

## DAILY MAINTENANCE



**WARNING:**

**Unplug power cord(s) before servicing or making any repairs.**

1. Flush the entire system, including floor tool, hand tool, etc., with 1 to 3 gallons of clean, hot water.
2. Vacuum out the solution tank.
3. Rinse tank with fresh water. Periodically inspect the recovery tank and decontaminate if necessary, using a Hospital Grade Virucide or a 1-10 bleach to water solution. Wastewater should be disposed of properly.
4. Occasionally check filter screen at the bottom of the solution tank and rinse clean with hot water if necessary.
5. Inspect hoses for wear. Frayed or cracked hoses should be replaced to avoid vacuum or solution pressure loss.
6. Inspect power cord for wear or damage. This cable will lie on wet carpet. To prevent electrical shock replace cords that are frayed or have cracked insulation immediately.
7. Clean all dirt and obstructions from drain valve and gaskets to prevent possible leakage and premature wear.
8. Run clean water through solution pump when work is complete.
9. Empty both tanks and rinse, run vacuum (s) for at least one minute to dry motor(s).
10. Store with access covers removed to allow tanks to dry.



**WARNING:**

**DO NOT attempt to repair hose! Repairing high-pressure hoses may result in severe burns and serious injury.**

## PERIODIC MAINTENANCE

1. Twice a month, flush a white vinegar solution (One quart vinegar to two gallons of water) or anti-browning solution (mixed as directed) through the extractor, turning pump switch on/off several times, flush with clean water. This will prevent build-up of alkaline residue in the system.

2. Check hoses for wear, blockages, or damage. Frayed or cracked hoses should be repaired or replaced to eliminate vacuum or solution pressure.
3. Check all handles, switches, knobs, electrical cables and connections on your machine for damage. If the cable insulation is broken or frayed, repair or replace it immediately. Don't take chances with electrical fire or shock.
4. Clean out solution tank. Remove and clean solution screen.
5. Clean outside of all tanks and check for damage.

## MONTHLY MAINTENANCE

1. Check all bearings for noise and wear.
2. Check all gaskets for wear and leakage.
3. Check pump pressure; observe spray pattern and check gauge if necessary.
4. Check overall performance of machine.

## SEMI-ANNUALLY

1. Check vacuum motor brushes.

## LUBRICATION

For pressure regulator and pump cam lubrication, use a light silicone lubricant which will not damage o-rings. A small tube (**51391**) is supplied with your machine.

## STORAGE

Thoroughly clean machine if it is to be stored. You must protect this machine from freezing while in storage.

By using the Self Priming Lever you may help clear out all water lines.

Make sure both recovery and solution tanks are empty. Turn on both vacuum switches and press lever. All water should be removed and sprayed into the recovery tank.

Empty the remaining water and wipe dry.

**HEAT MODELS ONLY:** Be sure to thoroughly drain water out of heater lines prior to storage in colder climates. This heater will freeze and possibly crack voiding your warranty.

## ⚠ WARNING:

Only qualified maintenance personnel are to perform the following repairs.

### VACUUM MOTOR REPLACEMENT

1. Turn off all switches and unplug machine.
2. Remove recovery tank.
3. Locate the vacuum motor wires and disconnect at the connector.
4. Remove the vacuum motor.
5. Reverse process to install vacuum motor.

### SOLUTION PUMP REPLACEMENT

1. Turn off all switches and unplug the machine.
2. Remove recovery tank.
3. Remove solution hoses from fittings in pump.
4. Remove the screws that fasten the pump to the frame.
5. Reverse process to install pump.

### Vacuum Motor Carbon Brushes Replacement (Windsor)

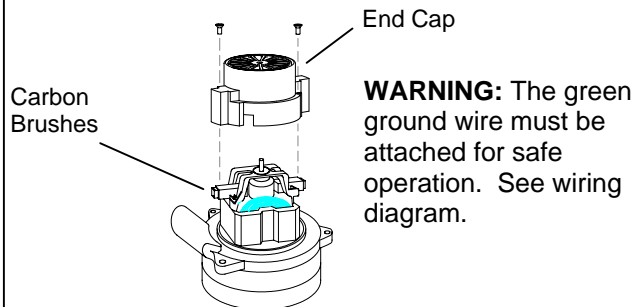

If armature commutator is grooved, extremely pitted or not concentric, the motor will need to be replaced or sent to a qualified service center.

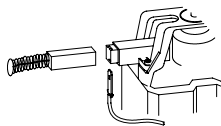

#### Important:

These brushes wear quicker as the length shortens due to increased heat. Spring inside brush housing will damage motor if brushes are allowed to wear away completely.

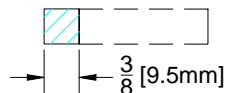

Periodically check the length of the carbon brushes. Replace both carbon brushes when either is less than 3/8" (9.5mm) long.

### Vacuum Motor Carbon Brushes Replacement (Ametek)

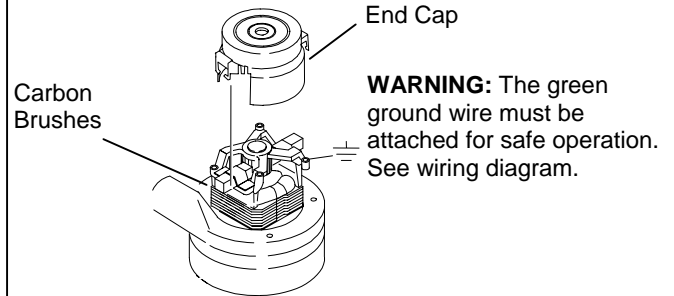

**Note:** When replacing carbon brushes loosen wire terminal **BEFORE** removing screws on bracket.

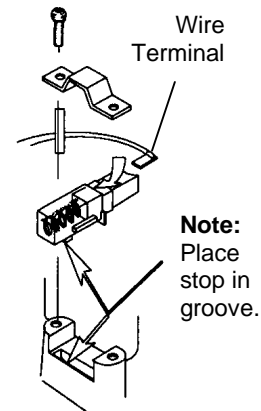

If armature commutator is grooved, extremely pitted or not concentric, the motor will need to be replaced or sent to a qualified service center.

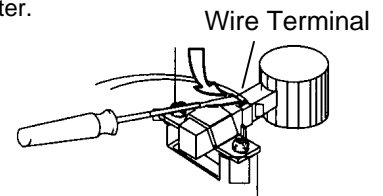

#### Important:

These brushes wear quicker as the length shortens due to increased heat. Spring inside brush housing will damage motor if brushes are allowed to wear away completely.

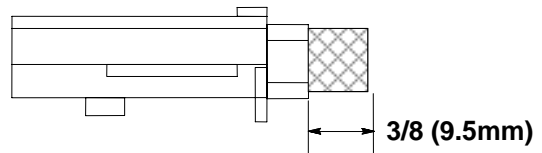

Periodically check the length of the carbon brushes. Replace both carbon brushes when either is less than 3/8" (9.5mm) long.

# MAINTENANCE

## PUMP REPLACEMENT KITS 200 PSI

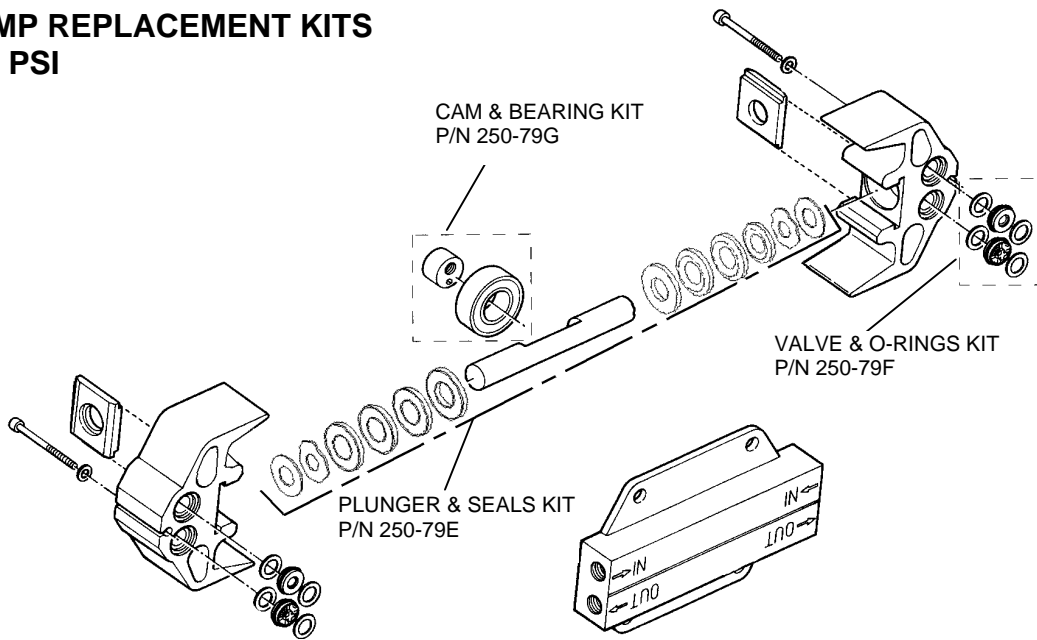

## PUMP REPLACEMENT KITS 500 PSI

MOTOR ONLY 53262

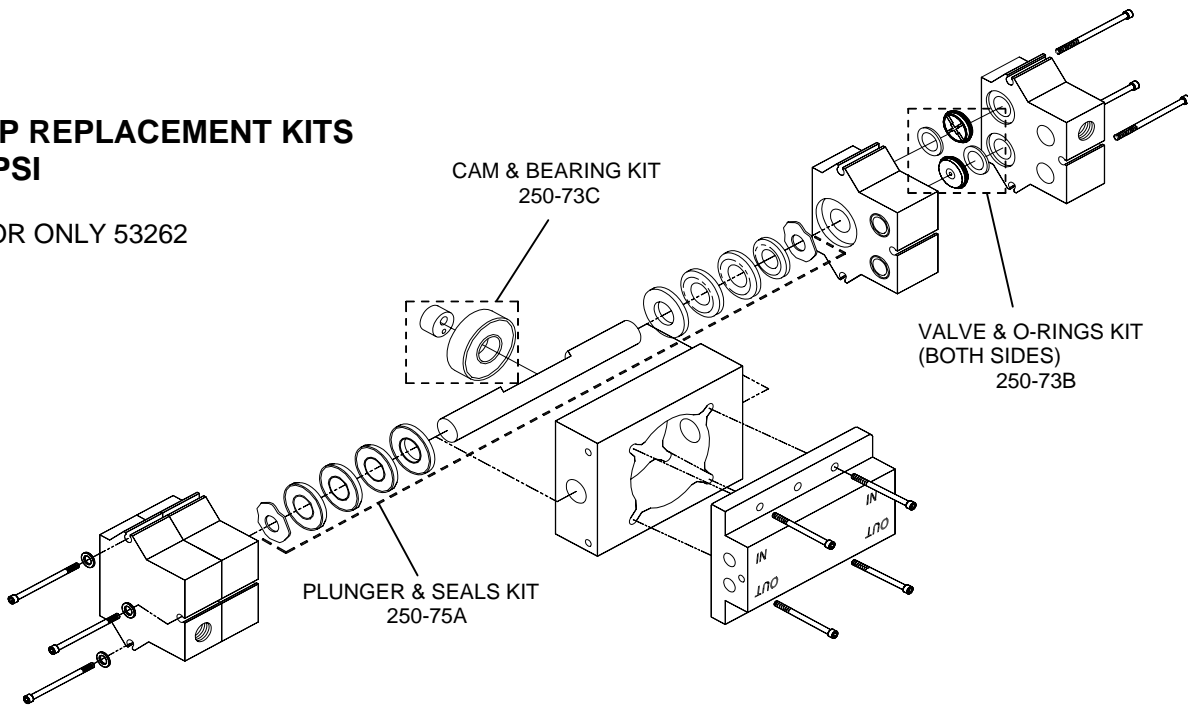

## PRESSURE REGULATOR

For best results with the pressure regulator, we recommend that you clean and lubricate the piston and u-cup with Superlube lubricant monthly or when pressure drop seems excessive.

1. Turn unit off before lubricating.
2. Remove cap, spring and spring retainer plate.
3. With fingertips remove piston and u-cup.
4. Wipe piston and u-cup clean of any film or scale.
5. Lubricate the piston and u-cup with Superlube.
6. Reassemble regulator.
7. With pump ON, re-adjust pressure regulator for normal operation.

---

**LUBRICATE U-CUP WITH SUPERLUBE MONTHLY.**

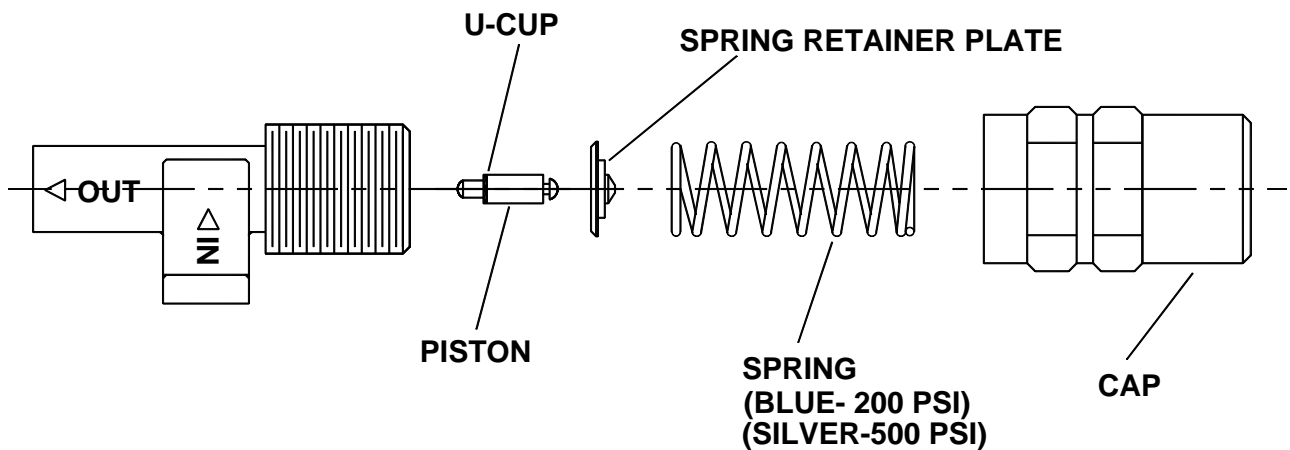

## MAINTENANCE

PROBLEM	CAUSE	SOLUTION
Loss of Power	Dead electrical circuit	Check building circuit breaker or fuse box.
	Faulty power cord	Replace
Electrical shock	Equipment not grounding	Follow grounding instructions exactly
	Receptacle not grounded	Contact an electrician to check building's wiring
	Internal wiring problem	Have a trained service technician check machine's wiring
Vac motor speed varies or doesn't run	Worn motor brushes	Replace
	Motor worn out	Replace
	Faulty switch	Replace
Loss of vacuum	Loose vacuum dome	Center and seal dome over tank
	Crack in dome of poor joint	Replace or repair using acrylic plastic cement only
	Lint or dirt clogging vacuum screen	With power off clean screen
	Loose cuffs on vacuum hose	Tighten cuffs turning counterclockwise
	Vac motor seals leaking	Replace
	Floor tool vac chamber clogged	Wash out with hose. Pick lint out with a wire
	Vac motor, hose, or dome gasket	Replace
Pump runs no solution	Pump inlet screen plugged	Clean inlet screen
	Pump air locked	Press trigger to open valve on cleaning wand to relieve air
	Internal or external solution line damaged and leaking	Replace
Pump runs, loss of pressure	Internal pump components wearing out	Replace, see pump kit components (pg 4-3)
	Note: Operation of pump using a wand or hand tool with an orifice of less than .06 will cause pump to cavitate or pulsate and could result in premature wear of pump components.	
	Check valves in pump head for particles or cuts in seals	Take piston from BPR and lubricate with Superlube. If problem still exists change BPR kit
Pump will not run	Unit not plugged in	Connect unit to 3 prong grounded outlet
	Loose wiring	See dealer
Solution hose fitting hard to connect	Corrosion on fittings.	Clean with steel wool. Soak in acetic acid (white vinegar). Lubricate lightly with silicone base lubricant.
Carpet not getting clean	Severe soil conditions	Make several passes at right angles to each other. Use a pre-spray.
Carpet too wet	Over saturation	Adjust solution pressure to lower settings. Make several passes without spray
Carpet browning	Leaving carpet too wet	Check for loss of vac pressure
	Too much chemical	Check label for correct solution concentration
	Light carpet with no brown prevention	Go over carpet with browning prevent only
Solution not flowing properly	Solution hose connection	Check for positive connection
	Faulty pump	Repair or replace
	Faulty floor tool valve	Repair or replace
	Faulty pump switch	Repair





# FRAME GROUP (200 PSI)

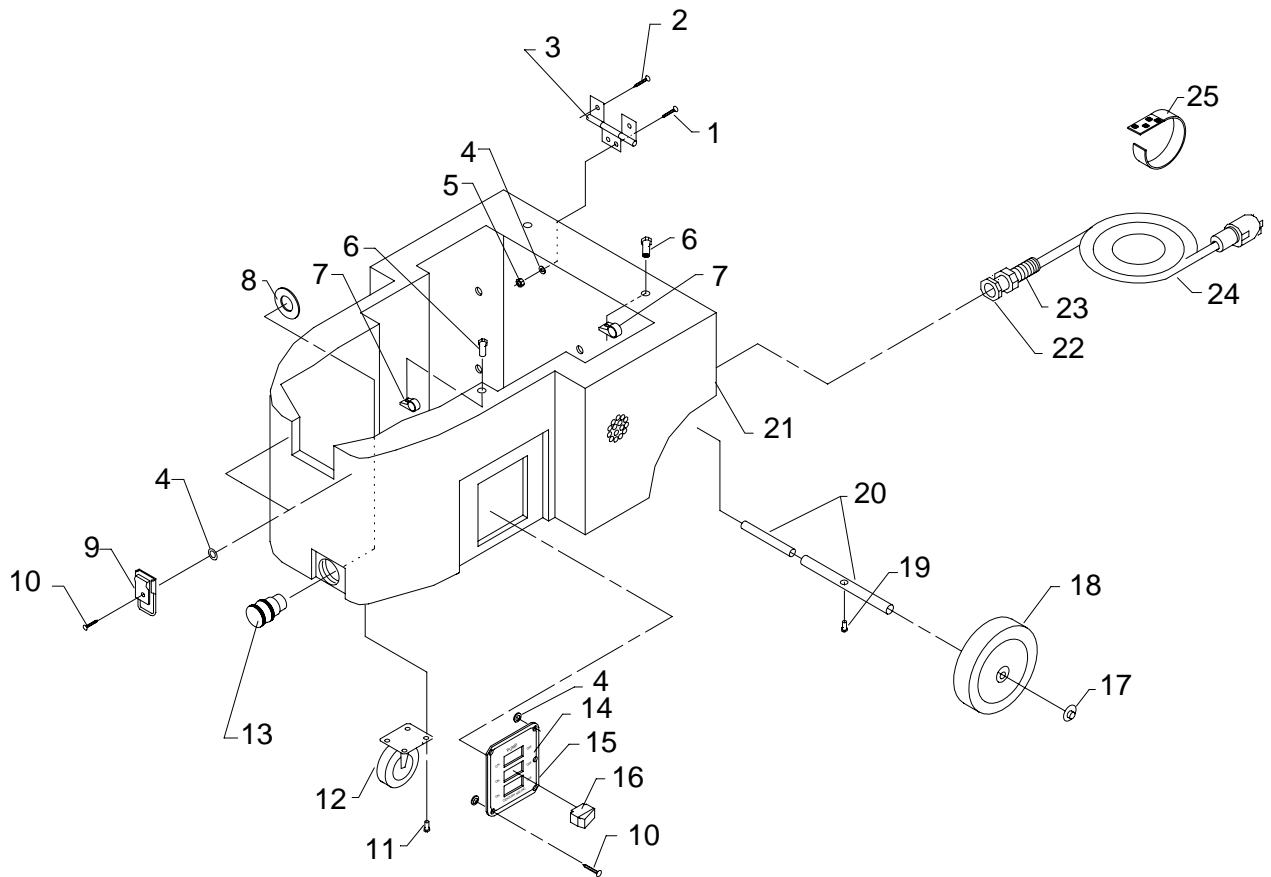

## FRAME GROUP (200 PSI)

REF	PART NO.	QTY	DESCRIPTION	SERIAL NO. FROM	NOTES:
1	70076	4	SCR, 10-32 X 1 PFHMS PLT		
2	70232	4	SCR, 10-32 X 3/8 FHMS SS		
3	140-01	1	HINGE SET CHROME		
4	87095	10	WASHER, #10 FLAT PLTD		
5	57030	4	NUT, 10-32 HEX NYLOCK		
6	280-03	2	RIVET ALUMINUM 3/16 X 3/4		
7	20008	2	CLAMP, 5/8 NYLON UL/USA		
8	390-09A	1	WASHER 9/16 S/S USS-THICK		
9	140-05	2	DRAW PULL LATCH STD.		
10	280-02	11	RIVET AL. 3/16 X 1/2 CLOSED		
11	70020	8	SCR, 1/4-20 X 1/2 HHCS SS NP		
12	040-03	2	CASTER SWIVEL 4" SWIVEL		
13	22015	1	COUPLER, 1/4 QD		
14	500359	1	LABEL, NINJA 3 SWITCH NO HEAT		
15	62900	1	PLATE, NINJA 3 SWITCH NO HEAT		
16	72142	3	SWITCH, SPST 15A EURO ROCKER		
17	57196	2	NUT, 1/2 PUSH-ON DOME CAP		
18	040-06	2	WHEEL 8" BLK CENTERED HUB		
19	70018	1	SCR, 1/4-20 X 1 HHCS SS		
20	010-04B	1	AXLE SINGLE NINJA		
21	08060	1	BASE, NJA 100 PSI 2ST N/H		
22	57040	1	NUT, 1/2 NPT CONDUIT		
23	73200	1	STRAIN RELIEF 1/2 NPT FLEX		
24	060-04A	1	CORD 25' BLK 14/3 SJTW/ A PLUG		
25	320-05	1	VELCRO STRAP		

# FRAME GROUP (500 PSI)

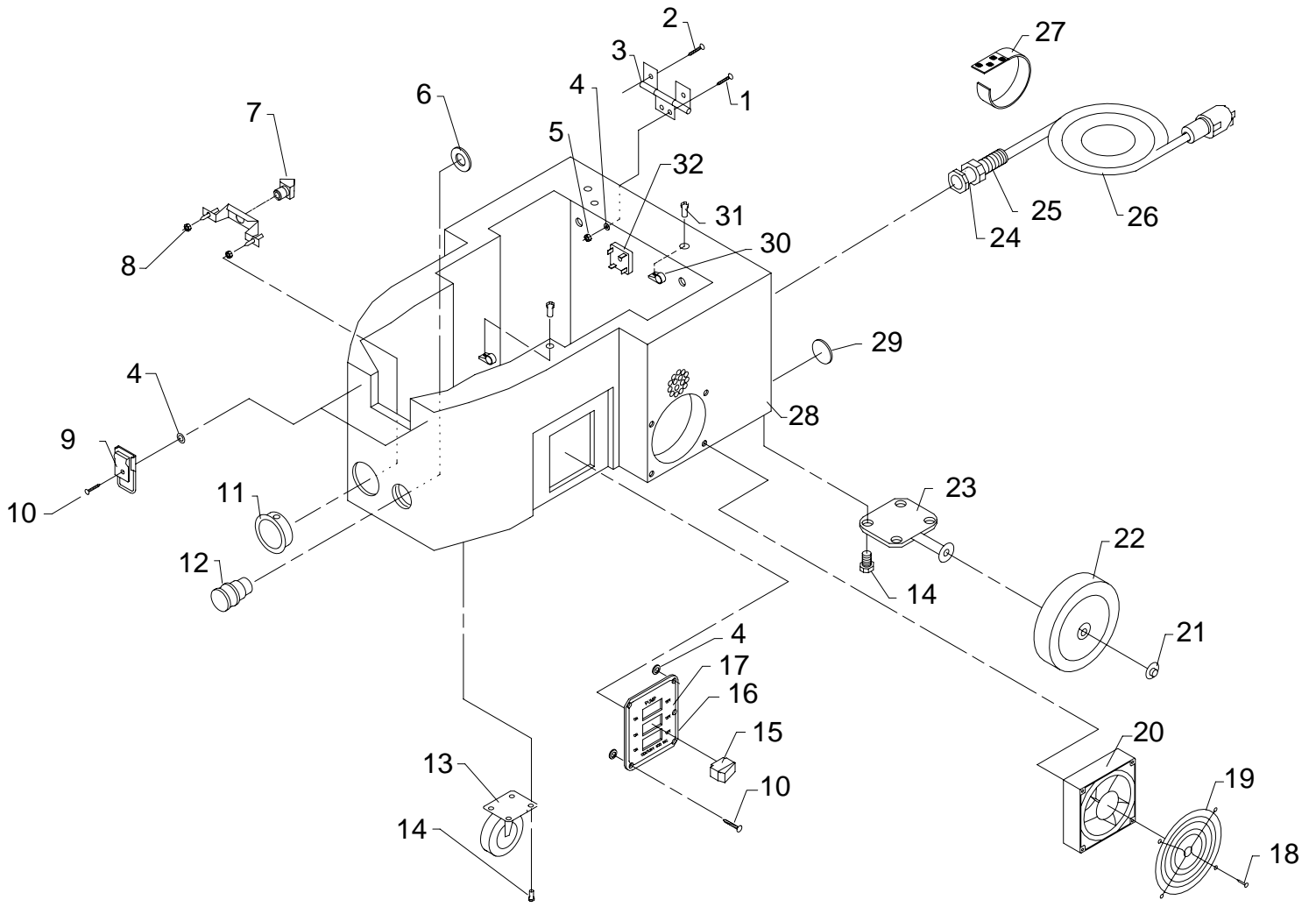

## FRAME GROUP (500 PSI)

REF	PART NO.	QTY	DESCRIPTION	SERIAL NO. FROM	NOTES:
1	70076	4	SCR, 10-32 X 1 PFHMS PLT		
2	70232	4	SCR, 10-32 X 3/8 FHMS SS		
3	140-01	1	HINGE SET CHROME		
4	87095	10	WASHER, #10 FLAT PLTD		
5	57030	4	NUT, 10-32 HEX NYLOCK		
6	390-09A	1	WASHER 9/16 S/S USS-THICK		
7	31021	1	ELBOW, 1/4 NPT X 45D STREET		
8	57104	2	NUT, 10-32 W/STAR WASHER PLTD		
9	140-05	2	DRAW PULL LATCH STD.		
10	280-02	11	RIVET AL. 3/16 X 1/2 CLOSED		
11	190-07	1	PRESSURE GAUGE 1000 PSI		
12	22015	1	COUPLER, 1/4 QD		
13	18036	2	CASTER 5" DIA SWIVEL		
14	70020	8	SCR, 1/4-20 X 1/2 HHCS SS NP		
15	72142	3	SWITCH, SPST 15A EURO ROCKER		
16	62900	1	PLATE, NINJA 3 SWITCH NO HEAT		
17	500359	1	LABEL, NINJA 3 SWITCH NO HEAT		
18	70626	4	SCR, #10 X 3/4 PPHST HI-LO BLK		
19	070-08A	1	FAN FINGER GUARD		
20	070-08	1	FAN 105 CFM AXIAL		
21	57196	2	NUT, 1/2 PUSH-ON DOME CAP		
22	89252	2	WHEEL, 12" BLK CNTRD HUB		
23	010-07	2	AXLE ASM, NJA		
24	57040	1	NUT, 1/2 NPT CONDUIT		
25	73200	1	STRAIN RELIEF 1/2 NPT FLEX		
26	060-04A	1	CORD 25' BLK 14/3 SJTW/ A PLUG		
27	320-05	1	VELCRO STRAPS		
28	08064	1	BASE, NJA DLX 500 2-3ST N/H		
29	110-14A	1	CAP PLUG 1"		
30	20008	2	CLAMP, 5/8 NYLON UL/USA		
31	280-03	2	RIVIT ALUMINUM 3/16 X 3/4		
* 32	67029	1	RECTIFIER, BRIDGE		SERVICE ONLY

\*INITIALLY ASSEMBLED WITH PUMP IN HEAT SHRINK.

# PUMP GROUP (200 PSI)

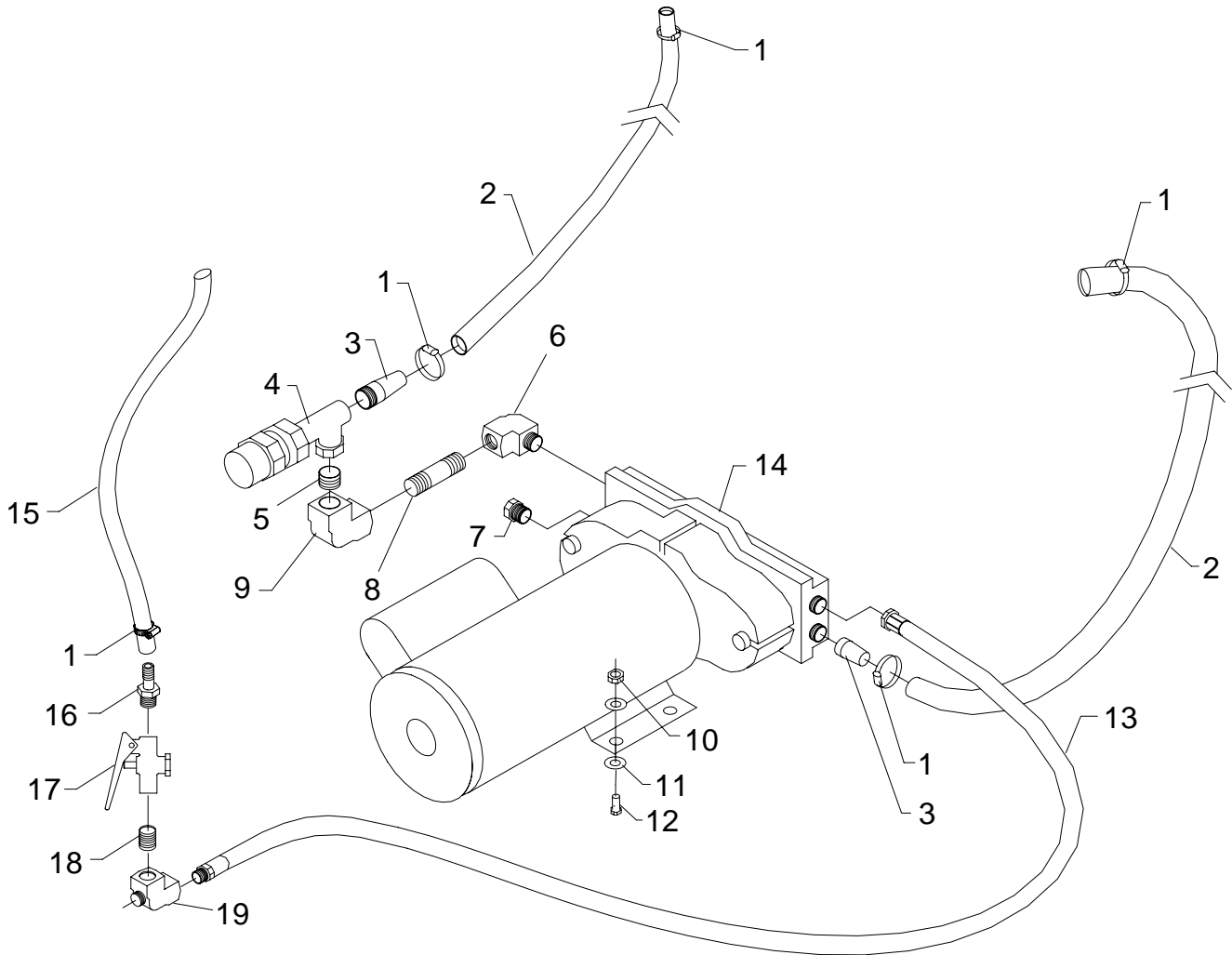

## **PUMP GROUP (200 PSI)**

REF	PART NO.	QTY	DESCRIPTION	SERIAL NO. FROM	NOTES:
1	20042	5	CLAMP, 3/8 HOSE (D-SLOT)		
2	151-38A	2	HOSE, 1/2 WIREBOUND X 21"		
3	40028	2	HOSEBARB, 1/4 MPT X 1/2 DL		
4	250-33	1	BPR PUMPTEC NINJA 200PSI		
5	56014	1	NIPPLE, 1/4 CLOSE		
6	31016	1	ELBOW, 1/4 NPT STREET		
7	66017	1	PLUG, 1/4 BRASS PIPE		
8	56022	1	NIPPLE, 1/4 X 3		
9	31017	1	ELBOW, 1/4 FPT X 1/4 FPT		
10	57245	2	NUT, 1/4-20 HEX NYLOCK SS		
11	87013	4	WASHER, 1/4 ID X 5/8 OD SS		
12	70019	2	SCR, 1/4-20 X 1.25 HHCS SS		
13	151-37C	1	HOSE, PULSE 24.0 1/4 MPT X 1/4 MPT		
14	250-79	1	PUMPTEC 200PSI PUMP & MOTOR		
15	39699	1	HOSE, 3/8 WIREBOUND X 35"		
16	40014	1	HOSEBARB, 1/4MPT X 3/8 DL		
17	84193	1	VALVE, KNGSTN 3" LVR 500 PSI		
18	56023	1	NIPPLE, 1/4 X 1.5		
19	78308	1	TEE, 1/4 STREET		

# PUMP GROUP (500 PSI)

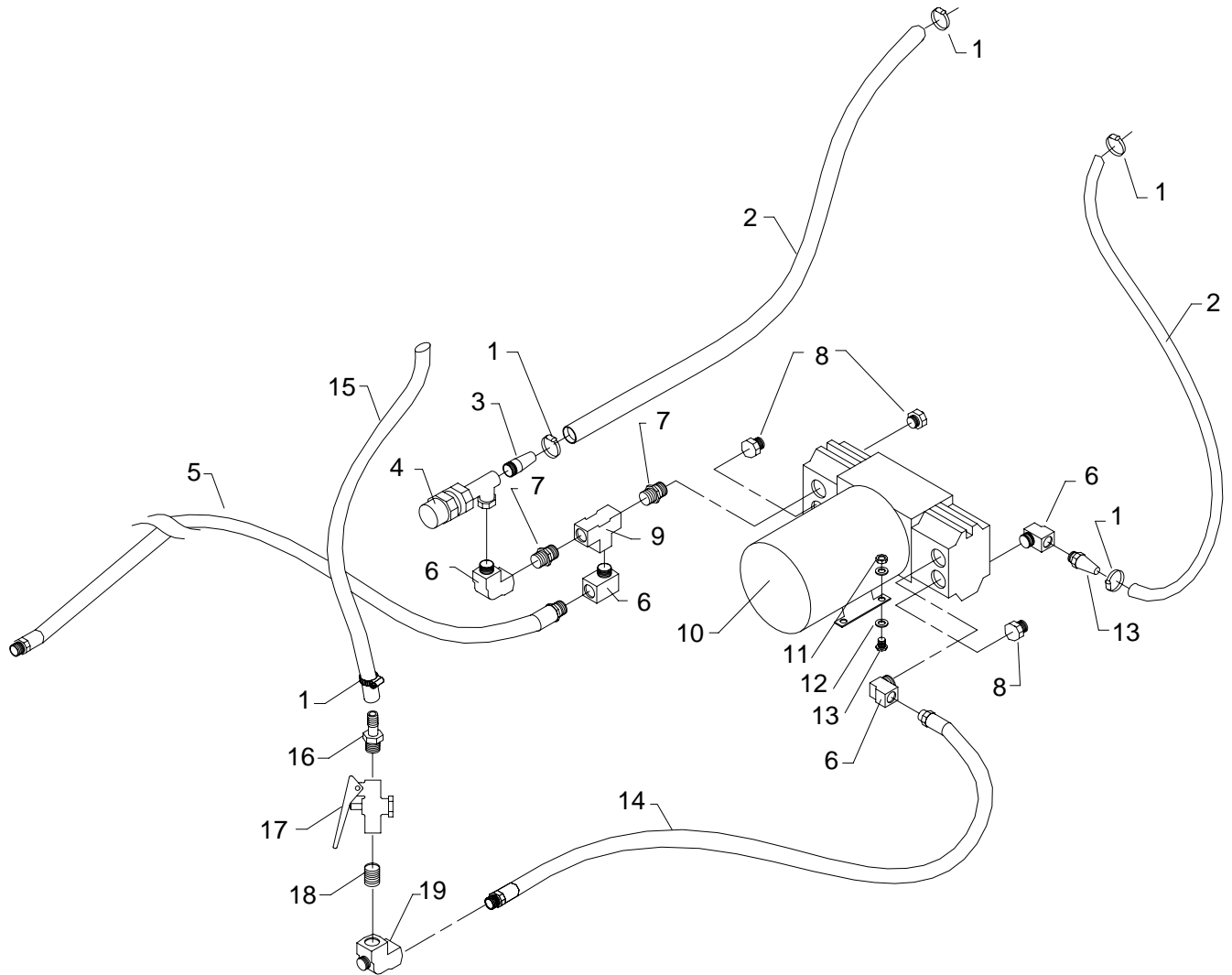

## PUMP GROUP (500 PSI)

REF	PART NO.	QTY	DESCRIPTION	SERIAL NO. FROM	NOTES:
1	20042	5	CLAMP, 3/8 HOSE (D-SLOT)		
2	151-38A	2	HOSE, 1/2 WIREBOUND X 21"		
3	40013	2	HOSEBARB, 3/8 MPT X 1/2 DL		
4	250-36	1	BPR 500 PSI		
5	151-42C	1	HOSE, PULSE 15.0 1/4 FBS X 3/8 MPT		
6	31026	3	ELBOW, 3/8 NPT STREET		
7	56005	2	NIPPLE, 3/8 X 1.5 BRASS		
8	66029	3	PLUG, 3/8 MPT		
9	78029	1	TEE, 3/8		
10	250-74	1	PUMPTEC 500 PSI PUMP/MOTOR		
11	57245	2	NUT, 1/4-20 HEX NYLOCK		
12	87013	4	WASHER, 1/4 ID X 5/8 OD SS		
13	70018	2	SCR, 1/4-20 X 1 HHCS SS		
14	39581	1	HOSE, PULSE 20.0 1/4 MPT X 3/8 MPT		
15	39699	1	HOSE, 3/8 WIREBOUND X 35"		
16	40014	1	HOSEBARB, 1/4MPT X 3/8 DL		
17	84193	1	VALVE, KNGSTN 3" LVR 500 PSI		
18	56023	1	NIPPLE, 1/4 X 1.5		
19	78308	1	TEE, 1/4 STREET		



# RECOVERY & SOLUTION TANK GROUP

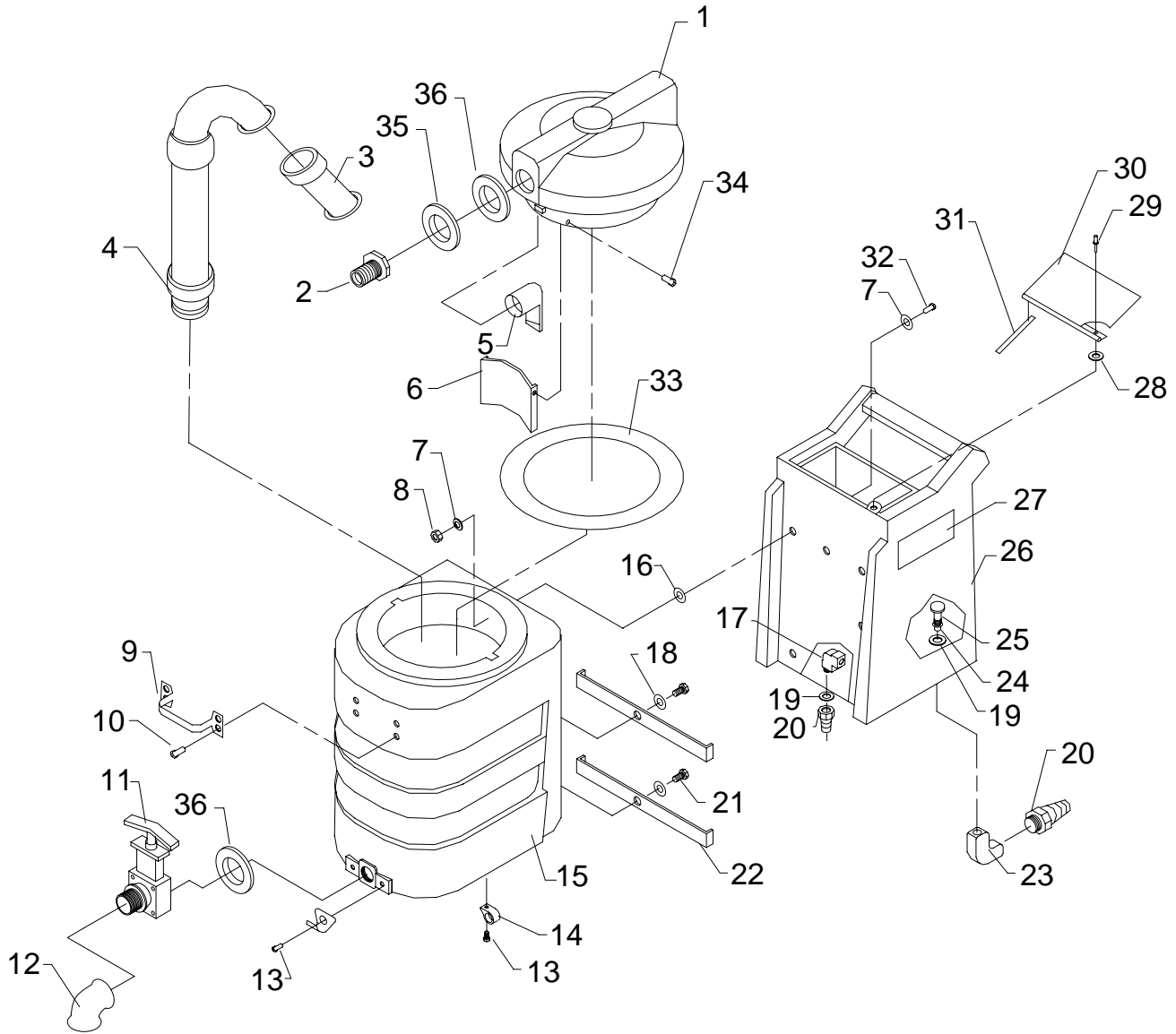

## RECOVERY & SOLUTION TANK GROUP

REF	PART NO.	QTY	DESCRIPTION	SERIAL NO. FROM	NOTES:
1	51355	1	LID, NJA DLX LT GRY ALL		
2	260-33	1	HOSEBARB, 1.5MPT X 1.5		
3	090-12A	1	FLOAT CAGE ASSY COMPLETE SLIP		
4	090-17	1	NINJA STAND PIPE ASSY		
5	31082	1	ELBOW, 1.5FS X 1.5FPT PVC MCHD		
6	065-42	1	FLOOD MACHINE BAFFLE		
7	87190	12	WASHER, SEAL 5/8 OD NEOPRENE		
8	57245	6	NUT, 1/4-20 HEX NYLOCK SS		
9	120-08	1	MACHINE HANDLE BRASS/CHROME		
10	70201	4	SCR, 1/4-20 X 3/4 FHCS DL		
11	15-808123	1	DUMP VALVE, 2"		
12	11-800444	1	ELBOW, 2" 45D PVC SCH40		
13	70683	5	SCR, 10-32 X 3/8 PPHMS SS NP		
14	20008	1	CLAMP, 5/8 NYLON UL/USA		
15	75330	1	TANK, RECVRY NJA ALL		
16	35182	6	GASKET, FRAME		
17	31017	1	ELBOW, 1/4 FPT X 1/4 FPT		
18	87013	2	WASHER, 1/4 ID X 5/8 OD SS		
19	87015	2	WASHER, 9/16 ID X 1.06 OD SS		
20	40028	2	HOSEBARB, 1/4 MPT X 1/2 DL		
21	70020	2	SCR, 1/4-20 X 1/2 HHCS SS NP		
22	065-37	2	BRKT, RECOVERY BUCKET NINJA		
23	030-13	1	ELBOW, 45 DEGREE 1/4 FPT		
24	56015	1	NIPPLE, 1/4 HEX		
25	290-08	1	SOL SCREEN (ACORN) W/RUB BASE		
26	75346	1	TANK, SLTN NJA 200/500 PSI		
27	500341	2	LABEL, NINJA MAIN		
28	87068	3	WASHER, 1/8 RIVET BACKUP		
29	280-01	3	RIVET AL. 1/8 X 1/2		
30	065-03C	1	SOLUTION COVER NINJA DELUXE		
31	99809	5"	FOAM TAPE, 1/8T X 3/4 1SDA		
32	70019	6	SCR, 1/4-20 X 1.25 HHCS SS		
33	110-26A	1	GASKET NINJA LID		
34	280-02	2	RIVET AL. 3/16 X 1/2 CLOSED		
35	87257	1	WASHER, HOSEBARB		
36	35256	2	GASKET, DUMP VALVE		

# VACUUM MOTOR GROUP

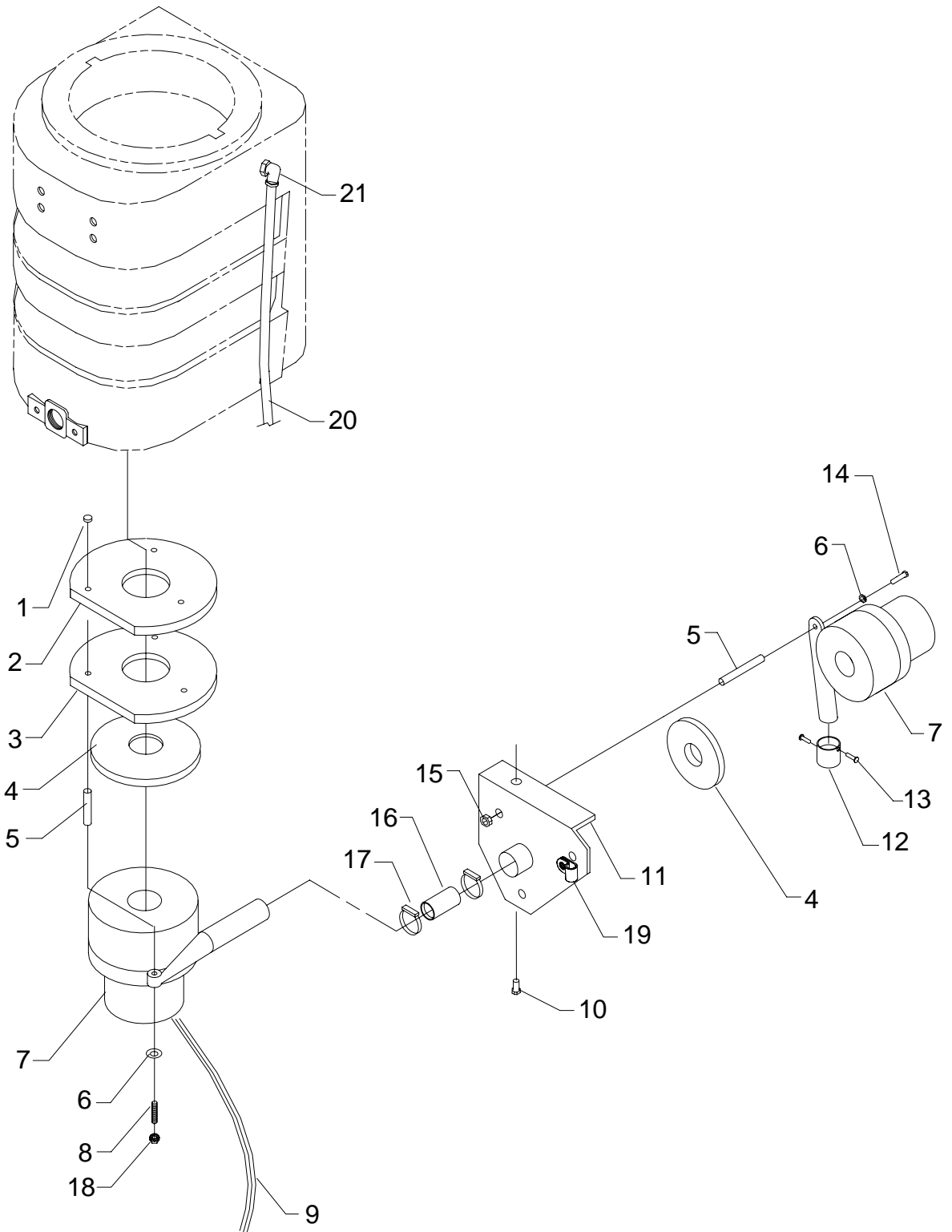

## VACUUM MOTOR GROUP

REF	PART NO.	QTY	DESCRIPTION	SERIAL NO. FROM	NOTES:
1	390-26	3	SPACER NYLON 1/4ID X 1/2OD		
2	110-26B	1	GASKET, VAC BRACKET		WAS 35168
3	360-23A	1	PLATE, VAC		
4	35166	2	GASKET, VAC MTR		
5	065-92	6	VAC SPACER 2 1/4 II STAGE		
6	87013	6	WASHER, 1/4ID X 5/8OD SS		
7	360-04A	2	VAC MOTOR, 120V 5.7 2 ST TD		
-	360-04B	-	BRUSHES, VAC FOR 116392-00		SERVICE ONLY
-	140687	-	BRUSH SET, 120V VAC WINDSOR	1000121568	SERVICE ONLY
8	70814	3	STUD, 1/4-20 X 4.5 SS		
9	99656	1	DUCT, 5/8 ID SPLIT FLEX		
10	70205	1	SCR, 1/4-20 X 3/8 HHCS PLT DL		
11	360-23	1	PLATE ASM, REAR VAC		
12	78463	1	TUBE, VAC EXHAUST 2.5" LONG		
13	280-01	2	RIVET AL. 1/8 X 1/2		
14	70663	3	SCR, 1/4-20 X 3-1/4 HHCS PLT		
15	57245	3	NUT, 1/4-20 HEX NYLOCK SS		
16	39566	1	HOSE, VAC EXHAUST 2"ID X 2" LONG		
17	20046	2	CLAMP, 2.25" WORM GEAR		
18	57105	3	NUT, 1/4-20 HEX W/ STAR WASHER		
19	20062	1	CLAMP, 3/8 NYLON MCHND		
20	39698	1	HOSE, 3/8 CLR PLYURTHN X 24"		
21	31076	1	ELBOW, 1/4MPT X 3/8 TUBE, QC		

# WIRING GROUP (200 PSI)

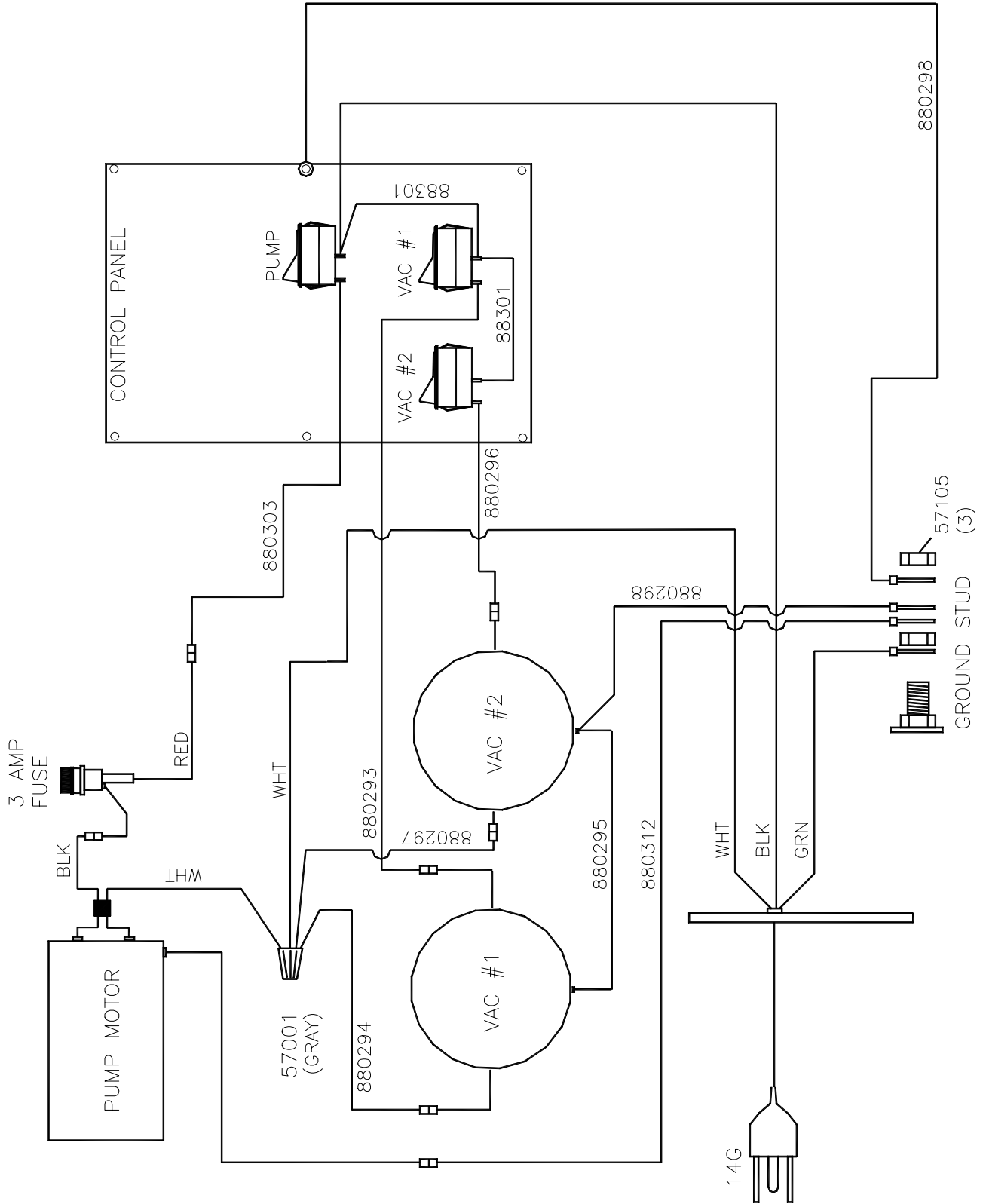

**WIRING GROUP (500 PSI)**

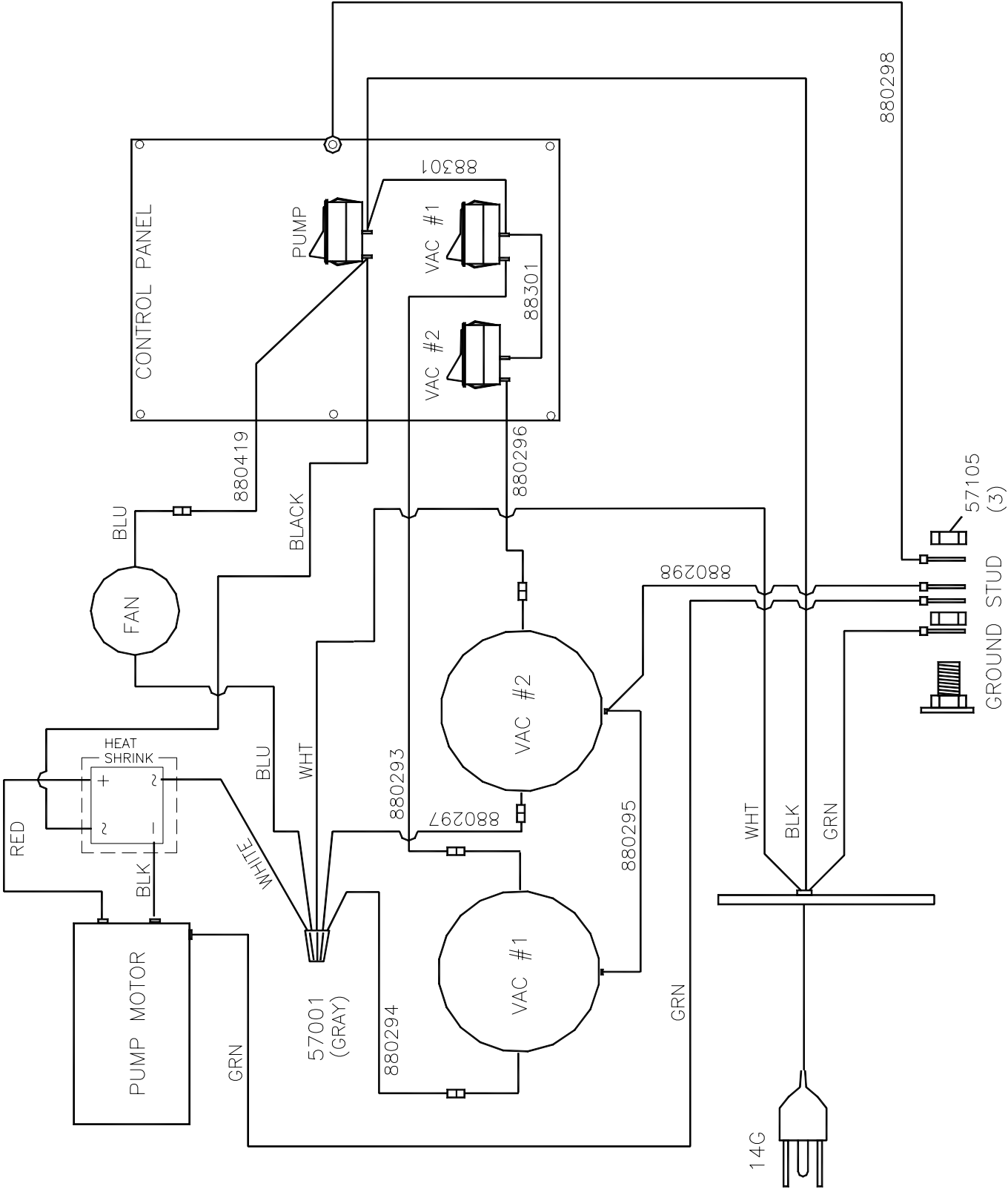



### **LIMITED WARRANTY**

The foregoing constitutes *Century 400's* entire warranty and no other warranty, liability, contingency or responsibility, direct, indirect, consequential or in any way connected with the sale or operation of *Century 400* machines or chemical products, either as expressed or implied, will be honored.

### **CONDITIONS OF WARRANTY**

This warranty shall not extend to any *Century 400* product showing effects of misuse, abuse, disassembly, alteration, lack of proper maintenance, corrosive chemicals, improper voltage, accident damage, unauthorized repairs, use of other than genuine *Century 400* parts and material, fire, flood, freezing, normal wear or other cause beyond *Century 400's* control.

### **LIMITED LIFETIME HOUSING WARRANTY**

We, *Century 400*, hereby warranty our polyethylene machine housing for life to the original distributor against cracking, leaking or deterioration. The limited lifetime warranty is offered to the original owner only. Any transfer in ownership will void warranty. Additional terms and conditions of the limited lifetime warranty on the housing are as follows: Ninja, Sensei, Spot Plus, Hurricane and Turbomist will receive a full lifetime 100% replacement warranty. The RT-Tanks will receive a (1) year 100% replacement warranty; all other polyethylene housings will receive a full (5) year 100% replacement warranty, followed by 50% replacement value for life.

### **WARRANTY ON CHEMICAL USE**

Improper use of chemicals voids warranty and *Century 400's* liability. Defoamer is to be used in all *Century 400* machines. Dry cleaning solvents cannot be used in any *Century 400* machine. If used, fire and/or pump damage could result. White vinegar should be pumped through the machine (1) time a week to prevent mineral scaling.

### **PARTS WARRANTY**

Parts for *Century 400* equipment shall have a (1) year replacement warranty from the date of purchase for conditions considered normal wear, excluding any and all freight charges.

### **90 DAY UNLIMITED WARRANTY**

Any equipment showing defect of any type within the first 90 days from date of purchase will have an unlimited warranty which includes parts, freight, and 100% of labor costs. No labor or freight will be covered after 90 days from the date of purchase.

### **LIMITED 90 DAY WARRANTY**

The following parts, considered expendable under normal use, will be covered by warranty for 90 days from the date of purchase: quick disconnects, o-rings, seals, diaphragms, gaskets, grommets, thermostats, brass fittings, hoses, etc. **This warranty will include parts only.**

### **USE OF PARTS NOT APPROVED BY CENTURY 400 WILL VOID ALL WARRANTIES.**

**NOTICE:** *Failure to complete and return the warranty card within (10) days of receipt of machine by purchaser will void all warranties.*



Century 400, Inc., 325 S. Price Road, Chandler, AZ 85224 USA  
Phone: (800) 752-1777 Fax: (480) 786-5724