

REVISED STARTING SERIAL NO. 060210009

PARTS LIST MANUAL

10" SELF-PROPELLED SCARIFIER



MODEL
CPU10FC-20H
SHOWN

CPU10FC SCARIFIERS

*SKU NO.	MODEL	POWER OPTION
73400	CPU10FC-20H	20 HP HONDA GX620, GASOLINE ENGINE
73500	CPU10FC-13H	13 HP HONDA GX390, GASOLINE ENGINE
73700	CPU10FC-12KC	12 HP KOHLER COMMAND CS12T, GASOLINE ENGINE
73600-230	CPU10FC-10B/230/3	10 HP BALDOR 3 PHASE MOTOR 230 VOLT, 23 FLA, ELECTRIC MOTOR
73600-460	CPU10FC-10B/460/3	10 HP BALDOR 3 PHASE MOTOR 460 VOLT, 11.5 FLA, ELECTRIC MOTOR
*ADD AN "R" SUFFIX TO ANY SKU NO. LISTED FOR SCARIFIER WITH OUTRIGGER FRONT WHEELS		

100 Thomas Johnson Drive, Frederick, MD 21702-4600 USA
 Phone (301) 663-1600 • 1-800-638-3326
 Fax (301) 663-1607 • 1-800-447-3326
 Website: www.edcoinc.com • Email: sales@edcoinc.com

Printed in USA
 ©2006

READ AND UNDERSTAND THE OPERATORS INSTRUCTION MANUAL THOROUGHLY BEFORE ATTEMPTING TO OPERATE THIS EQUIPMENT. Death or serious injury could occur if this machine is used improperly.



SAFETY MESSAGES



The safety instructions are preceded by a graphic alert message of DANGER, WARNING, or CAUTION.



Indicates an imminent hazard which, if not avoided, will result in death or serious injury.



Indicates an imminent hazard which, if not avoided, can result in death or serious injury.



Indicates hazards which, if not avoided, could result in serious injury and or damage to the equipment.

GASOLINE

Powered Equipment



- Do not operate gasoline powered equipment without adequate ventilation. Carbon monoxide is an invisible, odorless gas that can kill.

ELECTRICAL

Powered Equipment



- ELECTRICAL HAZARD** - Be sure equipment is properly grounded. Failure to comply could kill or result in serious injury.



The engine exhaust from this product contains chemicals known to the State of California to cause cancer, birth defects or other reproductive harm.

GENERAL INSTRUCTIONS



- You must read and understand the operators instruction manual and all other manuals associated with this machine. For your safety and the safety of others around you, it is extremely important to fully understand how to operate this machine in the way it was intended. Different model machines or older/newer versions of the same model may have different parts and controls that you need to understand. If instructions are not readable or available DO NOT USE this machine and contact the factory for a replacement Manual.
- You must be able to physically handle the bulk weight and power of this machine. If not properly controlled this machine can cause death or serious injury.
- Do not operate this machine in an impaired mental state. You must be able to exercise good judgement and reactions to maintain a safe working environment.
- This is a "one person" machine which means only one operator can be operating the machine at any one time. For the safety of others, maintain a safe operating distance to other personnel. Your work area should be defined and appropriately marked so bystanders and coworkers do not stand or walk near this machine and end up seriously injured by flying debris or exposing them to harmful noise or dust.
- This equipment is for Commercial use. Although this is a "one person" machine your work team should understand how to shut this machine off and quickly get medical help if an accident strikes the operator.
- Keep all guards in place during operation. The guards are to provide protection from inadvertent contact with dangerous moving parts, pinch points, or hot surfaces.
- Wear appropriate Personal Protective Equipment (PPE) including safety glasses, safety boots, work gloves, respiratory protection, hearing protection, and head protection. Do not wear loose clothing that can get tangled in moving parts. Failure to do so could result in dismemberment or death. **Wear an approved respirator when removing hazardous materials or when grinding/cutting dry materials. Some dust particles such as concrete dust can contain silicate particles which can cause silicosis (a very serious lung disease). Contact NIOSH or OSHA for further details. When wet grinding/cutting, avoid contact with the concrete/asphalt slurry which can cause serious skin irritations.**
- You must maintain this machine per the maintenance schedule in the operator manual. Remember before adjusting, servicing, or fueling this machine, disconnect the source of power to the machine by disconnecting the spark plug (Gas models), or by unplugging the electrical power cord (electric models) or air hose (Pneumatic models) AT THE MACHINE so you can assure yourself it remains unplugged while you are working on it. Do not modify this machine. Use only genuine EDCO parts and accessories. Repairs and service should be performed by approved EDCO dealers or authorized technicians.
- You should look carefully around the area before you begin work so you can identify potential hazards such as deck inserts, pipes, columns, openings, electrical cords or outlets, or any other objects protruding from the slab surface.
- This machine has no brain so you must use your own. There is no substitute for safety. The safety decals on the machine are to serve as a reminder for information you must already know before you begin using this machine. Take a moment to reread the safety decals each time you use the machine. If your machine is missing any decals, contact the factory for a replacement (EDCO 1-800-638-3326).

PARTS LIST MANUAL

MODEL CPU10FC

Section	Page Number
Safety Messages/General Instructions.	2
How To Order Replacement Parts.	3
Illus. 1: Frame Grouping	4,5
Illus. 2: Lifting System Grouping.	6,7
Illus. 3: Transmission Grouping	8,9
Illus. 4: Clutch & Rear Axle Grouping.	10,11
Illus. 5: Honda Engine Grouping For 20HP Units	12,13
Illus. 6: Engine Grouping For 12HP & 13HP Units.	14,15
Illus. 7: Electric Motor Grouping.	16,17
Illus. 8: Belt Drive Grouping.	18,19
Illus. 9: Drum Bearing & Axle Grouping	20
Illus. 10: Standard 4-Shaft Cutter Drum Grouping	21
Illus. 11: Optional 6-Shaft Cutter Drum Grouping	22
Illus. 12: Optional Diamond Grooving Head Grouping	23
Limited Equipment Warranty	Back Page

HOW TO ORDER REPLACEMENT PARTS

- To insure product safety and reliability, always use genuine EDCO replacement parts when making repairs to the equipment.

- When calling for parts, specify the MODEL and SERIAL NUMBER of the machine which can be found on the NAME PLATE. Keep that information in the space provided. In addition to this information, give part number, description and quantity as listed on the parts list to your parts representative.

- Please note: Due to improvements and changes in the equipment, the illustrations shown may be different than the actual machine.

FILL IN INFORMATION BELOW

Date of Purchase _____

Name of Machine _____

Model # _____

Serial # _____

Belt Size(s) _____

Toll Free: 1-800-638-3326

FAX: 1-800-447-3326

email: sales@edcoinc.comwww.edcoinc.com

100 Thomas Johnson Drive, Frederick, MD 21702-4600 USA

Phone (301) 663-1600 • 1-800-638-3326

Fax (301) 663-1607 • 1-800-447-3326

Website: www.edcoinc.com • Email: sales@edcoinc.com

Printed in USA

©2006

Page 3

ILLUSTRATION 1: FRAME GROUPING

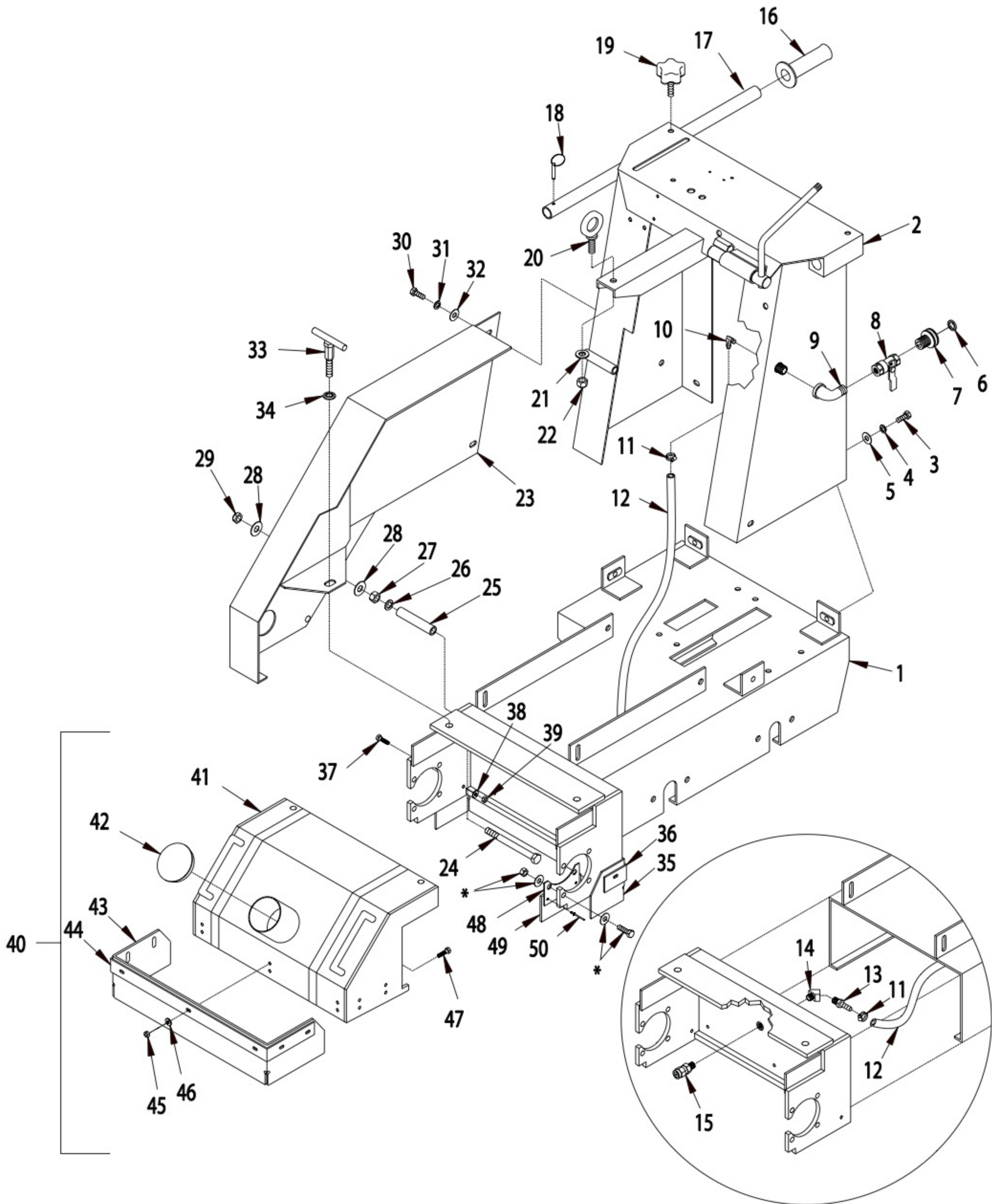

PARTS LISTING - ILLUSTRATION 1: FRAME GROUPING			
ITEM#	PART#	DESCRIPTION	QTY.
1	64401	MAIN FRAME	1
2	64007	CONSOLE	1
3	10055	SCREW, CAP 3/8-16 x 1	3
4	10811	WASHER, LOCK 3/8	3
5	10025	WASHER, FLAT 3/8	3
6	10070	WASHER, HOSE 3/4	1
7	80021	CONN., SWIVEL FEM. 3/4HOSE X 1/2MPT (INCLUDES ITEM 6)	1
8	10711	VALVE, BALL 1/2 FPT	1
9	10724	ELBOW, STREET 1/2 NPT x 90°(BLACK)	1
10	10799	BARB, ELBOW 90°, 3/8 HOSE x 1/4 MPT	1
11	10714	CLAMP, HOSE SIZE M4 ADJ. TO 5/8"	2
12	64058	HOSE, WATER 3/8"ID x 37"L	1
13	50075	BARB, 3/8 HOSE x 1/4 MPT	1
14	10716	ELBOW, STREET 1/4 NPT x 45°(BRASS)	1
15	80029	NOZZLE, SPRAY 1/4 NPT(BRASS)	1
16	61108	GRIP, HAND 1" MODEL SX	2
17	51024	HANDLE BAR 24"L	2
18	10145	PIN, DETENT RING 3/16 x 1-5/16" EFF. L	2
19	51230	KNOB, STAR CLAMPING(3/8-16 x 1 STUD)	2
20	10837	BOLT, EYE 1/2-13 x 1-1/2 x 1-1/8"ID	1
21	10312	WASHER, FLAT 1/2 SAE	1
22	10155	NUT, HEX NYLON LOCK 1/2-13	1
23	64070	COVER, BELT	1
24	64071	SCREW, CAP 1/2-13 x 5-1/2	1
25	64072	SPACER, BELT COVER 1/2"ID x 3-7/8"L	1
26	10045	WASHER, LOCK 1/2	1
27	10417	NUT 1/2-13	1
28	10312	WASHER, FLAT 1/2	2
29	10157	NUT, HEX NYLON JAM 1/2-13	1
30	10055	SCREW, CAP 3/8-16 x 1	2
31	10811	WASHER, LOCK 3/8	2
32	10025	WASHER, FLAT 3/8	2
33	64003	LOCK, HOOD	2
34	11522	WASHER, SERRATED BELLEVILLE .489" ID	2
35	64406	RUBBER SEAL, REAR	1
36	64405	RETAINING BRKT., REAR SEAL	1
37	10031	SCREW, CAP 1/4-20 X 1	4
38	10602	WASHER, FLAT 1/4	4
39	10150	NUT, HEX NYLON LOCK 1/4-20	4
40	64402A	HOOD SUBASSEMBLY (INCLUDES ITEMS 41-47)	1
41	64402	HOOD ONLY	1
42	64030	PLUG, CAP 3" TUBE	1
43	64404	RUBBER SEAL, FRONT	1
44	64403	RETAINING BRKT., FRONT SEAL	1
45	10150	NUT, HEX NYLON LOCK 1/4-20	7
46	10602	WASHER, FLAT 1/4	7
47	10031	SCREW, CAP 1/4-20 X 1	7
--	64407	RUBBER SEAL W/ BRKT. (INCLUDES ITEMS 48 & 49)	1
48	64408	RETAINING BRKT., SIDE SEAL	2
49	64409	RUBBER SEAL, SIDE	2
50	11643	RIVET, BLIND 3/16"DIA	4
51	10816	SCREW, CAP 3/8-24 X 1-1/2 (SEE ILLUS. 9, ITEM 4)	-
52	10025	WASHER, FLAT 3/8 SAE (SEE ILLUS. 9, ITEM 5)	-
53	10152	NUT, HEX NYLON LOCK 3/8-24 (SEE ILLUS. 9, ITEM 6)	-



100 Thomas Johnson Drive, Frederick, MD 21702-4600 USA

Phone (301) 663-1600 • 1-800-638-3326

Fax (301) 663-1607 • 1-800-447-3326

Website: www.edcoinc.com • Email: sales@edcoinc.com

Printed in USA

©2006

Page 5

ILLUSTRATION 2: LIFTING SYSTEM GROUPING

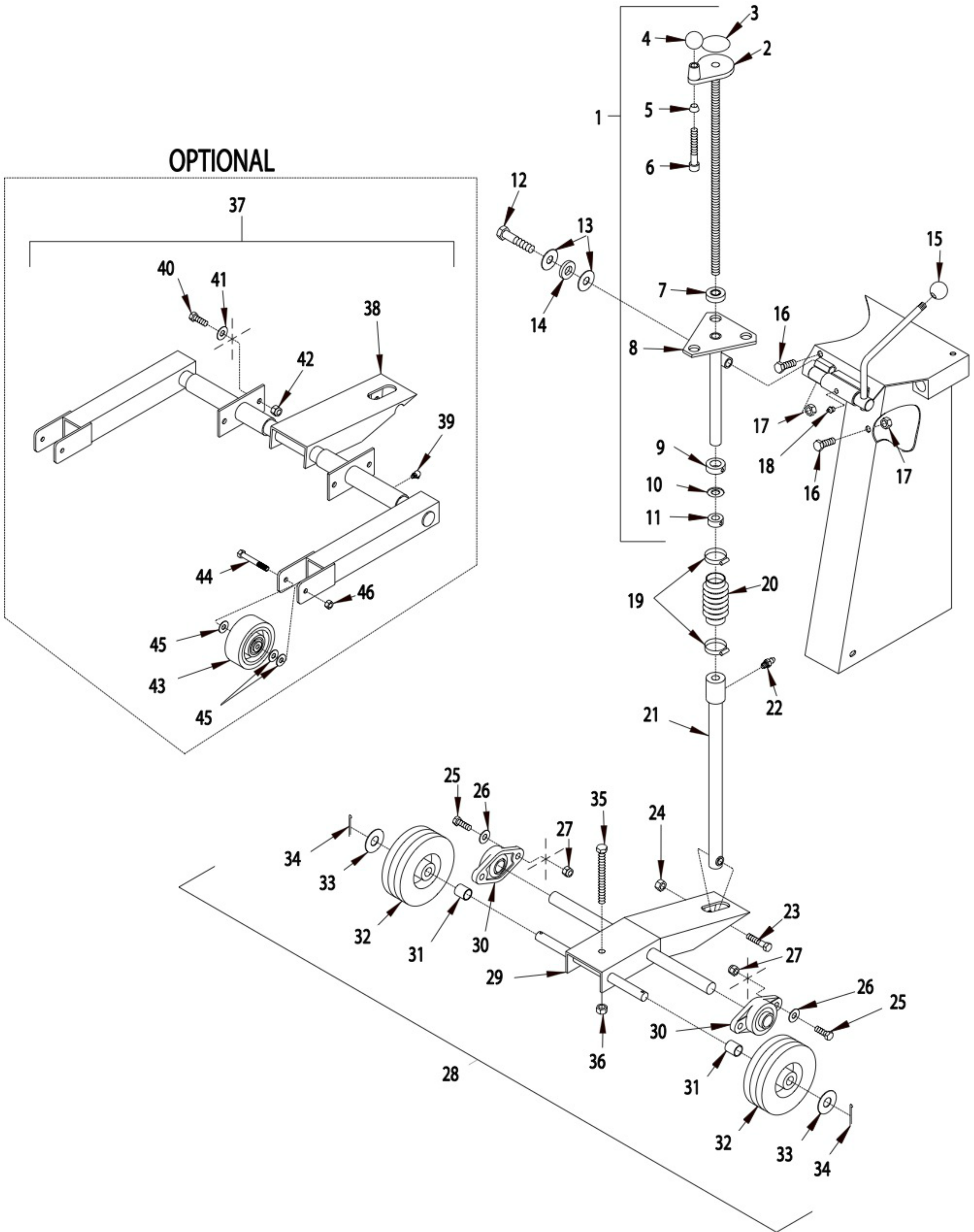

PARTS LISTING - ILLUSTRATION 2: LIFTING SYSTEM GROUPING			
ITEM#	PART#	DESCRIPTION	QTY.
1	64011A	HANDWHEEL SUBASSEMBLY (INCLUDES ITEMS 2-11)	1
2	64011	HANDWHEEL, SMALL W/ 5/8-8 x 20" ROD	1
3	80007	DECAL, CUT CONTROL DN-UP(SMALL ROUND)	1
4	14023	KNOB, BALL 1-3/8"DIA. W/1/2-13 THREADS	1
5	50550	SLEEVE FOR 1/2" CAPSCREW, TAPERED	1
6	10411	SCREW, SOCKET HEAD CAP 1/2-13 x 4	1
7	85005	BEARING, BALL 5/8"ID x 1-1/2" OD THRUST	1
8	64013	LINKAGE, UPPER SUPPORT	1
9	10440	COLLAR, LOCKING 7/8" ID	1
10	10073	WASHER, FLAT 5/8	1
11	10096	COLLAR, LOCKING 5/8" ID	1
12	10326	SCREW, CAP 5/8-11 x 3	1
13	10073	WASHER, FLAT 5/8	2
14	79035	BUSHING, RUBBER 1-1/16"OD x 5/8"ID x 1/4" THK.	1
15	14023	KNOB, BALL 1-3/8"DIA. W/1/2-13 THD.	1
16	10308	SCREW, CAP 1/2-20 x 1-1/2	2
17	10154	NUT, HEX NYLON LOCK 1/2-20	2
18	10808	FITTING, GREASE 1/4-28 STRAIGHT	1
19	10784	CLAMP, HOSE SIZE 20, ADJ. TO 1-3/4"	2
20	10930	BELLOWS-1-1/4" ID x 2-3/8"E.L. x 1-3/4"R.L.	1
21	64012	LINKAGE, LOWER CONTROL 18"L	1
22	10808	FITTING, GREASE 1/4-28 STRAIGHT	1
23	10347	SSCREW, CAP 1/2-20 X 2-1/4	1
24	10154	NUT, HEX NYLON LOCK 1/2-20	1
25	10003	SCREW, CAP 7/16-20 x 1-1/4"	4
26	10062	WASHER, FLAT 7/16	4
27	10153	NUT, HEX NYLON 7/16-20	4
28	64006A	FORK SUBASSEMBLY (INCLUDES ITEMS 29-36)	1
29	64006	FORK	1
30	62022	BEARING, BALL 1" 2-HOLE FLANGE	2
31	64031	SPACER, WHEEL 3/4" ID x 1"L	2
32	80028	WHEEL 6 x 2 x 3/4" BEARING	2
33	10009	WASHER, FLAT 3/4	2
34	10306	PIN, COTTER 3/16 x 1-1/4	2
35	10373	BOLT, TAP 1/2-13 x 5(FULL THREAD)	1
36	10417	NUT 1/2-13	1
37	64450	OUTRIGGER WHEEL ASSEMBLY COMPLETE (INCLUDES ITEMS 38-46)	1
38	64451	OUTRIGGER FORK	1
39	10961	FITTING, GREASE 1/4-28 x 90°	2
40	10003	SCREW, CAP 7/16-20 x 1-1/4	4
41	10062	WASHER, FLAT 7/16	4
42	10153	NUT, HEX NYLON LOCK 7/16-20	4
43	10932	WHEEL 4 x 1-1/2 x 3/8" BRG., POLY TREAD	2
44	10815	SCREW, CAP 3/8-24 x 2-3/4	2
45	10025	WASHER, FLAT 3/8	6
46	10004	NUT, LOCK 3/8-24	2



100 Thomas Johnson Drive, Frederick, MD 21702-4600 USA

Phone (301) 663-1600 • 1-800-638-3326

Fax (301) 663-1607 • 1-800-447-3326

Website: www.edcoinc.com • Email: sales@edcoinc.com

Printed in USA

©2006

Page 7

ILLUSTRATION 3: TRANSMISSION GROUPING

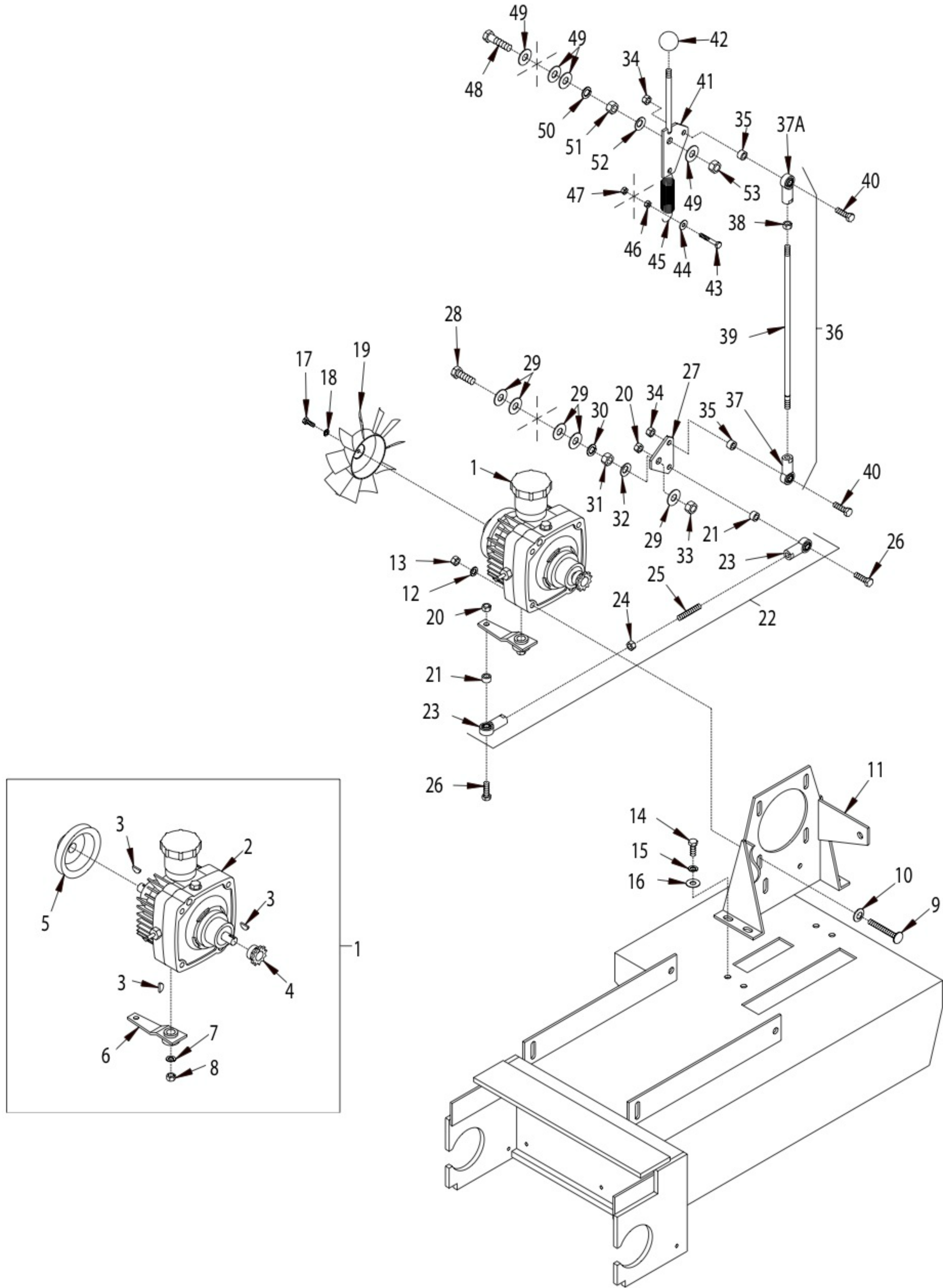

PARTS LISTING - ILLUSTRATION 3: TRANSMISSION GROUPING			
ITEM#	PART#	DESCRIPTION	QTY.
1	50061A	TRANSMISSION SUBASSEMBLY (INCLUDES ITEMS 2-8)	1
2	50061	TRANSMISSION, HYDROSTATIC	1
3	50071	KEY, WOODRUFF 1/8 x 1/2(#404)	3
4	50048	SPROCKET #3511 x .67" BORE	1
5	50062	SHEAVE, HYD. TRANS. 4"OD x 1Gr. x .671"B	1
6	64022	TRANSMISSION CONTROLARM	1
7	10811	WASHER, LOCK 3/8	1
8	10404	NUT 3/8-16	1
9	10909	BOLT, CARRIAGE 3/8-16 x 3	4
10	10040	WASHER, GARRET 1"OD x 17/32"ID x .054"T	4
11	64018	MOUNT, TRANSMISSION	1
12	10811	WASHER, LOCK 3/8	4
13	10404	NUT 3/8-16	4
14	10055	SCREW, CAP 3/8-16 x 1	4
15	10811	WASHER, LOCK 3/8	4
16	10025	WASHER, FLAT 3/8	4
17	10018	SCREW, CAP 1/4-20 x 3/4	1
18	10038	WASHER, LOCK 1/4	1
19	50266	FAN BLADE W/ PLATE 7", TRANSMISSION	1
20	10152	NUT, HEX NYLON LOCK 3/8-24	2
21	10011	SPACER, STEEL 5/8"OD x 3/8"ID x 3/8"	2
22	64024A	LINKAGE SUBASSY., DRIVE HORIZ.(INCLUDES ITEMS 23-25)	1
23	10919	ROD END, FEMALE 3/8-24 R.H. THREADS	2
24	10014	NUT 3/8-24	1
25	64024	ROD, ALL THREAD 3/8-24 x 2"L	1
26	10816	SCREW, CAP 3/8-24 x 1-1/2	2
27	64021	BELL CRANK, DRIVE LINKAGE	1
28	10322	SCREW, CAP 1/2-20 x 2	1
29	10312	WASHER, FLAT 1/2	5
30	10045	WASHER, LOCK 1/2	1
31	10417	NUT 1/2-13	1
32	10040	WASHER, GARRET 1"OD x 17/32"ID x .054"T	1
33	10154	NUT, HEX NYLON LOCK 1/2-20	1
34	10152	NUT, HEX NYLON LOCK 3/8-24	2
35	10011	SPACER, STEEL 5/8"OD x 3/8"ID x 3/8"	2
36	64023A	LINKAGE SUBASSY., DRIVE VERT. (INCLUDES ITEMS 37-39)	1
37	10919L	ROD END, FEMALE 3/8-24 L.H. THREAD	1
37A	10919	ROD END, FEMALE 3/8-24 R.H. THREAD	1
38	10014	NUT 3/8-24	1
39	64023	LINKAGE, ROD 3/8 x 14-1/4"L	1
40	10816	SCREW, CAP 3/8-24 x 1-1/2	2
41	64020	LEVER, DRIVE	1
42	10920	KNOB, BALL 1-3/8"DIA. W/ 5/16-24 THD.	1
43	10314	SCREW, CAP 1/4-20 x 1-3/4	1
44	10602	WASHER, FLAT 1/4	1
45	50074	SPRING, EXT. 1"OD x 3-15/16" INSIDE ENDS	1
46	10015	NUT, LOCK 1/4-20	1
47	10150	NUT, HEX NYLON LOCK 1/4-20	1
48	10322	SCREW, CAP 1/2-20 x 2	1
49	10312	WASHER, FLAT 1/2	4
50	10045	WASHER, LOCK 1/2	1
51	10417	NUT 1/2-13	1
52	10040	WASHER, GARRET 1"OD x 17/32"ID x .054"T	1
53	10154	NUT, HEX NYLON LOCK 1/2-20	1



ILLUSTRATION 4: CLUTCH & REAR AXLE GROUPING

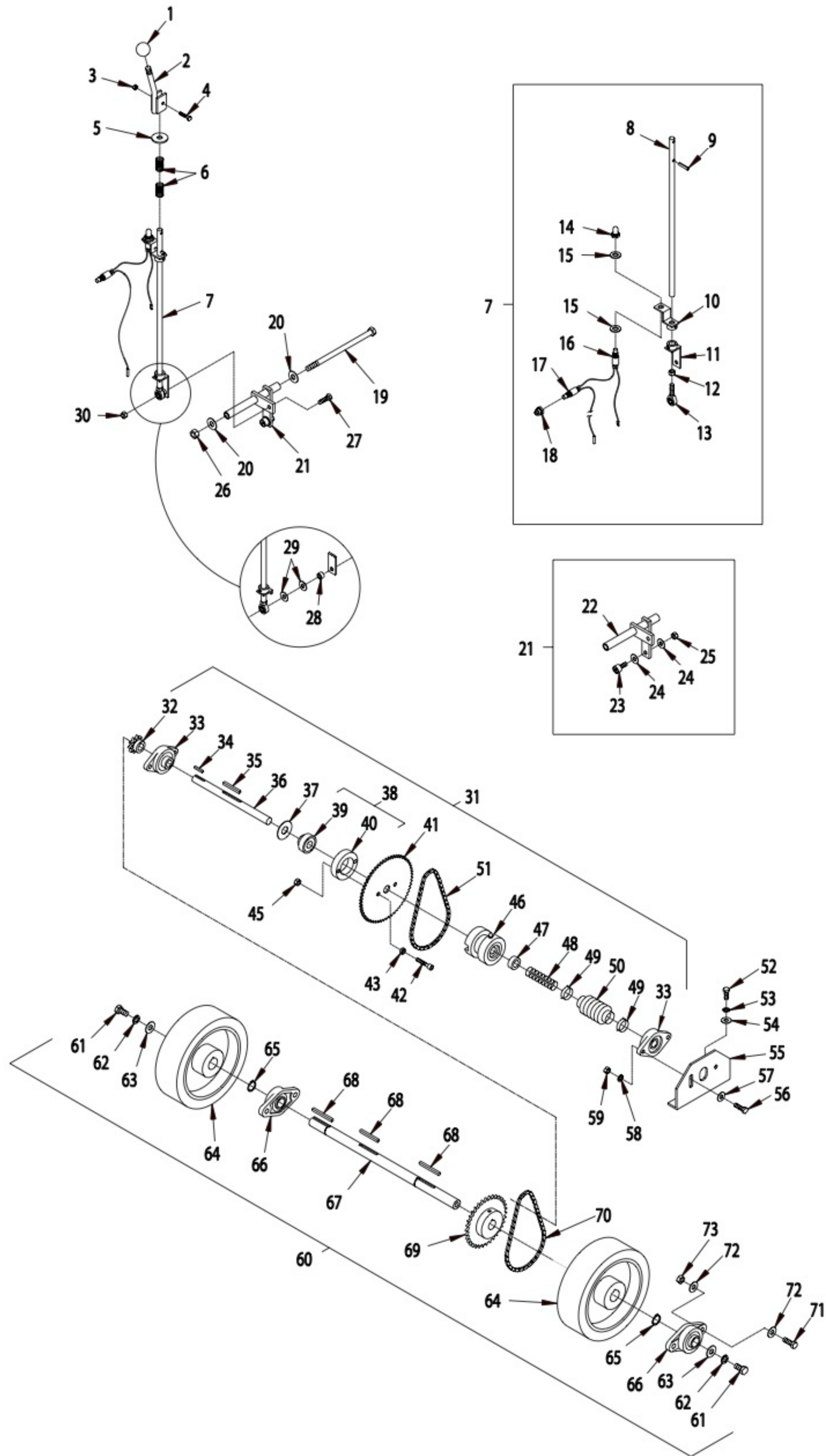

PARTS LISTING - ILLUSTRATION 4: CLUTCH & REAR AXLE GROUPING							
ITEM#	PART#	DESCRIPTION	QTY.	ITEM#	PART#	DESCRIPTION	QTY.
1	14023	KNOB, BALL 1-3/8"DIA. W/1/2-13 THD.	1	39	57038	BEARING, BALL 3/4"ID x 1.8504"OD	1
2	64025	LEVER, CLUTCH	1	40	57039	CARRIER, CLUTCH BEARING	1
3	10150	NUT, HEX NYLON LOCK 1/4-20	1	41	50476	SPROCKET, CLUTCH #35A60	1
4	10905	SCREW, CAP 1/4-20 x 1-1/4	1	42	10354	SCREW, SKT. HEAD CAP 3/8-24 x 1-3/4	2
5	10433	WASHER, BELLEVILLE SPRING 1/2"ID x 3/32"	1	43	10113	SPACER, STEEL 9/16"OD x 3/8"ID x 7/32"	2
6	10921	SPRING, COMP. .72"OD x 1.25"FL x .08"WD	2	45	10152	NUT, HEX NYLON LOCK 3/8-24	2
7	57126A	CLUTCH LINKAGE SUBASSEMBLY (INCLUDES ITEMS 8-18)	1	46	50477	CLUTCH, DOG, SUBASSEMBLY	1
				*	57042	CLUTCH, DOG BLOCK	1
8	57126	LINKAGE, CLUTCH 19-1/4"L	1	*	3695	SEAL, OIL .750 x 1.375 x .250	1
9	10024	PIN, ROLL 1/4 x 1-1/4	1	*	10808	FITTING, GREASE 1/4-28 STRAIGHT	1
10	64082	BRACKET, SAFETY SWITCH	1	47	57044	CLUTCH, SPRING CUP	1
11	57151	BRACKET, CLUTCH LINKAGE LOCK	1	48	10922	SPRING, COMP. 1"OD x 3.75"FL x .105"WD	1
12	10014	NUT 3/8-24	1	49	10768	CLAMP, HOSE, SAE #16, ADJ. TO 1-1/2"	2
13	3605	ROD END, MALE 3/8-24	1	50	10930	BELLOWS: 1-1/4"ID x 2-3/8"E.L. x 1-3/4"R.L.	1
14	10997	BOOT, RED RUBBER, STOP SWITCH	1	51	64032	CHAIN #35 x 24-1/2" L.O.A. (INCLUDES #35 CONNECTING LINK)	1
15	10312	WASHER, FLAT 1/2	2				
16	10992	SWITCH, PUSH BUTTON, 1PST N.O., MOMENT.	1	52	10055	SCREW, CAP 3/8-16 x 1	2
17	10887	SWITCH, PUSH BUTTON, 1PST N.C., MOMENT.	1	53	10811	WASHER, LOCK 3/8	2
18	10674	BOOT, TOGGLE SWITCH	1	54	10025	WASHER, FLAT 3/8	2
19	10408	SCREW, CAP 1/2-13 x 9	1	55	50509	MOUNT, JACKSHAFT BEARING	1
20	10312	WASHER, FLAT 1/2	2	56	10309	SCREW, CAP 3/8-24 x 1-1/4	4
21	64026A	BELLCRANK SUBASSEMBLY, CLUTCH (INCLUDES ITEMS 22-25)	1	57	10025	WASHER, FLAT 3/8	4
				58	10811	WASHER, LOCK 3/8	4
22	64026	BELL CRANK, CLUTCH	1	59	10014	NUT 3/8-24	4
23	10924	CAM FOLLOWER BRG. 3/4 x 3/8-24 THD.	1	60	64028A	AXLE & WHEEL SUBASSEMBLY (INCLUDES ITEMS 61-69)	1
24	10025	WASHER, FLAT 3/8	2				
25	10152	NUT, HEX NYLON LOCK 3/8-24	1	61	10914	SCREW, CAP 1/2-13 x 1	2
26	10155	NUT, HEX NYLON LOCK 1/2-13	1	62	10045	WASHER, LOCK 1/2	2
27	10030	SCREW, CAP 3/8-24 x 2	1	63	10433	WASHER, BELLEVILLE SPRING 1/2"ID x 3/32"	2
28	10011	SPACER, STEEL 5/8"OD x 3/8"ID x 3/8"	1	64	50098	WHEEL 8 x 2 x 1" BORE	2
29	10025	WASHER, FLAT 3/8	2	65	10906	RETAINING RING, EXT. 1"	2
30	10152	NUT, HEX NYLON LOCK 3/8-24	1	66	62022	BEARING, BALL 1" 2-HOLE FLANGE	2
31	64027A	CLUTCH & JACKSHAFT SUBASSEMBLY (INCLUDES ITEMS 32-50)	1	67	64028	AXLE SHAFT 1"RD x 20-3/8"L	1
				68	10307	KEY 1/4"SQ. x 2-1/4"L	3
32	50436	SPROCKET #40B10 x 3/4" BORE	1	69	61126	SPROCKET #40B34 x 1"BORE	1
33	50049	BEARING, BALL 3/4" 2-HOLE FLANGE	2	70	64033	CHAIN #40 x 25-3/4"L (INCLUDES #40 OFFSET & CONNECTING LINKS)	1
34	50523	KEY 3/16"SQ. x 1-1/8"L	1				
35	10307	KEY 1/4"SQ. x 2-1/4"L	1	71	10003	SCREW, CAP 7/16-20 x 1-1/4	4
36	64027	JACKSHAFT, CLUTCH 10-1/2"L	1	72	10062	WASHER, FLAT 7/16	8
37	10009	WASHER, FLAT 3/4	1	73	10153	NUT, HEX NYLON LOCK 7/16-20	4
38	57038A	BEARING & CARRIER ASSEMBLY, CLUTCH (INCLUDES ITEMS 39 & 40)	1				



ILLUSTRATION 5: HONDA ENGINE GROUPING FOR 20HP UNITS

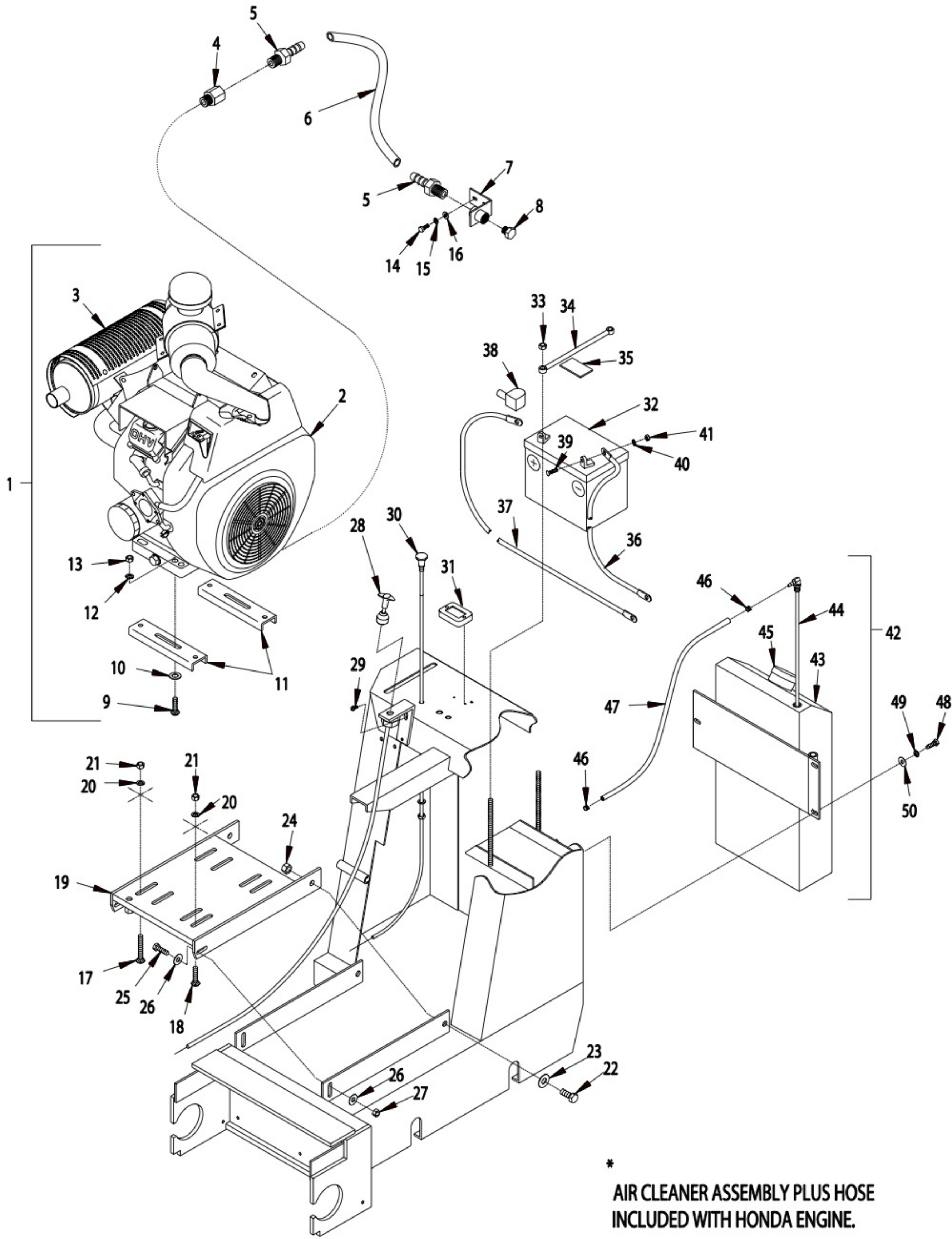

*
AIR CLEANER ASSEMBLY PLUS HOSE
INCLUDED WITH HONDA ENGINE.



PARTS LISTING-ILLUSTRATION 5: HONDA ENGINE GROUPING FOR 20HP UNITS

ITEM#	PART#	DESCRIPTION	QTY.	ITEM#	PART#	DESCRIPTION	QTY.
1	15056A	ENGINE SUBASSY., HONDA 20HP (INCLUDES ITEMS 2-13)	1	28	51081	CABLE, TURN-TO-LOCK CONTROL 72" (CUT TO LENGTH 54")	1
2	15056	ENGINE, HONDA 20HP GX620-K1TZF2	1	29	10846	SCREW, SELF-TAP HEX WASHER 1/4-20x1/2	2
3	15168	MUFFLER, HONDA VHRM3	1	30	15129	CABLE, CHOKE 72" (CUT TO LENGTH 58")	1
4	11533	FITTING, ADAPTER 6-M14 x 1.5 TO 1/4-18 NPT	1	31	15138	METER, HOUR REDINGTON INDUCTIVE	1
5	11579	BARB, PUSH ON, 1/2 HOSE x 1/4 MPT	2	32	84011	BATTERY, 12 VOLT/300 C.C.A.	1
6	64057	HOSE, PUSH ON, 1/2ID x 10-1/2"L	1	33	10156	NUT, HEX NYLON LOCK 3/8-16	2
7	57159	BRACKET, OIL DRAIN	1	34	64008	CLAMP, BATTERY HOLD DOWN	1
8	50552	PIPE PLUG, 1/2 NPT (BRASS)	1	35	64049	RUBBER PAD 2-1/2"L x 1-1/2"W x 1/8 THICK	1
9	10087	BOLT, CARRIAGE 3/8-16 x 1-3/4	2	36	50117B	CABLE, EYE TO EYE, 4 GA. x 24" (BLACK)	1
10	10040	WASHER, GARRET 1"OD x 17/32"ID x .054"T	4	37	50117R	CABLE, EYE-EYE 4GA. X 24" (RED)	1
11	51014	MOUNT BRACKET, CHANNEL	2	38	11583	INSULATOR, BATTERY TERMINAL U-1 STYLE RED L.H.	1
12	10811	WASHER, LOCK 3/8	2	39	10818	BOLT, CARRIAGE 5/16-18 x 3/4	2
13	10404	NUT 3/8-16	2	40	10801	WASHER, LOCK 5/16	2
14	10018	SCREW, CAP 1/4-20 x 3/4	2	41	10054	NUT 5/16-18	2
15	10038	WASHER, LOCK 1/4	2	42	64014A	GAS TANK SUBASSEMBLY (INCLUDES ITEMS 43-45)	1
16	10602	WASHER, FLAT 1/4	2	43	64014	TANK, GAS (INCLUDES CAP, ITEM 45)	1
17	10335	BOLT, CARRIAGE 3/8-16 x 2-1/2	2	44	61058	TUBE, FUEL PICK UP 19"	1
18	10804	BOLT, CARRIAGE 3/8-16 x 1-1/2	2	45	61056	CAP, GAS TANK	1
19	64017	MOUNT, ENGINE	1	46	10762	CLAMP, HOSE-SPRING TYPE 3/8" GREEN	2
20	10811	WASHER, LOCK 3/8	4	47	64035	HOSE, FUEL 1/4" ID x 50"	1
21	10404	NUT 3/8-16	4	48	10053	SCREW, CAP 5/16-18 x 3/4	3
22	10321	SCREW, CAP 1/2-20 X 1-1/4	2	49	10801	WASHER, LOCK 5/16	3
23	10312	WASHER, FLAT 1/2 SAE	2	50	10213	WASHER, FLAT 5/16	3
24	10154	NUT, HEX NYLON LOCK 1/2-20	2				
25	10309	SCREW, CAP 3/8-24 X 1-1/4 PLATED	2				
26	10025	WASHER, FLAT 3/8 SAE	4				
27	10152	NUT, HEX NYLON LOCK 3/8-24	2				



100 Thomas Johnson Drive, Frederick, MD 21702-4600 USA

Phone (301) 663-1600 • 1-800-638-3326

Fax (301) 663-1607 • 1-800-447-3326

Website: www.edcoinc.com • Email: sales@edcoinc.com

Printed in USA

©2006

Page 13

ILLUSTRATION 6: ENGINE GROUPING FOR 12HP & 13HP UNITS

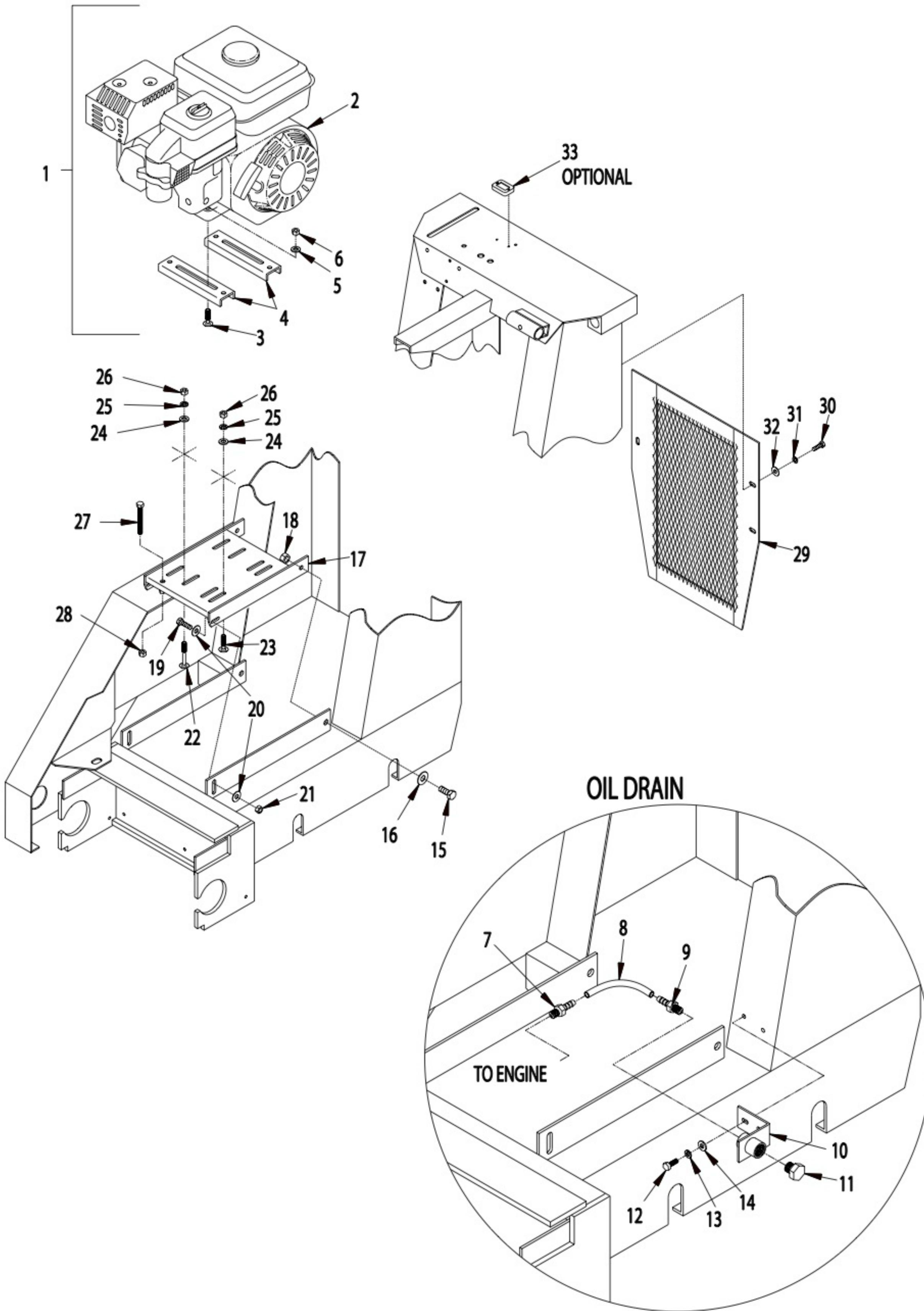

PARTS LISTING-ILLUSTRATION 6: ENGINE GROUPING FOR 12HP & 13HP UNITS			
ITEM#	PART#	DESCRIPTION	QTY.
1	15029A	ENGINE SUBASSEMBLY, HONDA 13HP(SHOWN) (INCLUDES ITEMS 2-11)	1
	15045A	ENGINE SUBASSEMBLY, KOHLER 12HP (INCLUDES ITEMS 2-11)	
2		ENGINE	1
	15029	HONDA 13HP GX390K1-QXC9 (SHOWN)	
	15045	KOHLER 12HP COMMAND PRO CS12T	
3	10804	BOLT, CARRIAGE 3/8-16 x 1-1/2	2
4	51014	MOUNT BRACKET, CHANNEL	2
5	10025	WASHER, FLAT 3/8	2
6	10404	NUT 3/8-16	2
7	11542	BARB, PUSH ON 3/8"ID x 12mm x 1.50 MALE	1
8	64068	HOSE, PUSH ON 3/8"ID x 12"L	1
9	11580	BARB, PUSH ON 3/8"ID x 1/2MPT	1
10	57159	BRACKET, OIL DRAIN	1
11	50552	PIPE PLUG, 1/2 NPT	1
12	10018	SCREW, CAP 1/4-20 x 3/4	2
13	10038	WASHER, LOCK 1/4	2
14	10602	WASHER, FLAT 1/4	2
15	10321	SCREW, CAP 1/2-20 x 1-1/4	2
16	10312	WASHER, FLAT 1/2	2
17	64017	MOUNT, ENGINE	1
18	10154	NUT, HEX NYLON LOCK 1/2-20	2
19	10309	SCREW, CAP 3/8-24 x 1-1/4	2
20	10025	WASHER, FLAT 3/8	4
21	10152	NUT, HEX NYLON LOCK 3/8-24	2
22	10908	BOLT, CARRIAGE 3/8-16 x 2-1/2	2
23	10804	BOLT, CARRIAGE 3/8-16 x 1-1/2	4
24	10025	WASHER, FLAT 3/8	4
25	10811	WASHER, LOCK 3/8	4
26	10404	NUT 3/8-16	4
27	10340	BOLT, TAP 1/2-13 x 3(FULL THREAD)	1
28	10417	NUT 1/2-13	1
29	64066	GRILL, REAR	1
30	10806	SCREW, CAP 5/16-18 x 1	3
31	10801	WASHER, LOCK 5/16	3
32	10213	WASHER, FLAT 5/16	3
33	15138	METER, HOUR, REDINGTON INDUCTIVE (OPTIONAL)	1



100 Thomas Johnson Drive, Frederick, MD 21702-4600 USA

Phone (301) 663-1600 • 1-800-638-3326

Fax (301) 663-1607 • 1-800-447-3326

Website: www.edcoinc.com • Email: sales@edcoinc.com

Printed in USA

©2006

Page 15

ILLUSTRATION 7: ELECTRIC MOTOR GROUPING

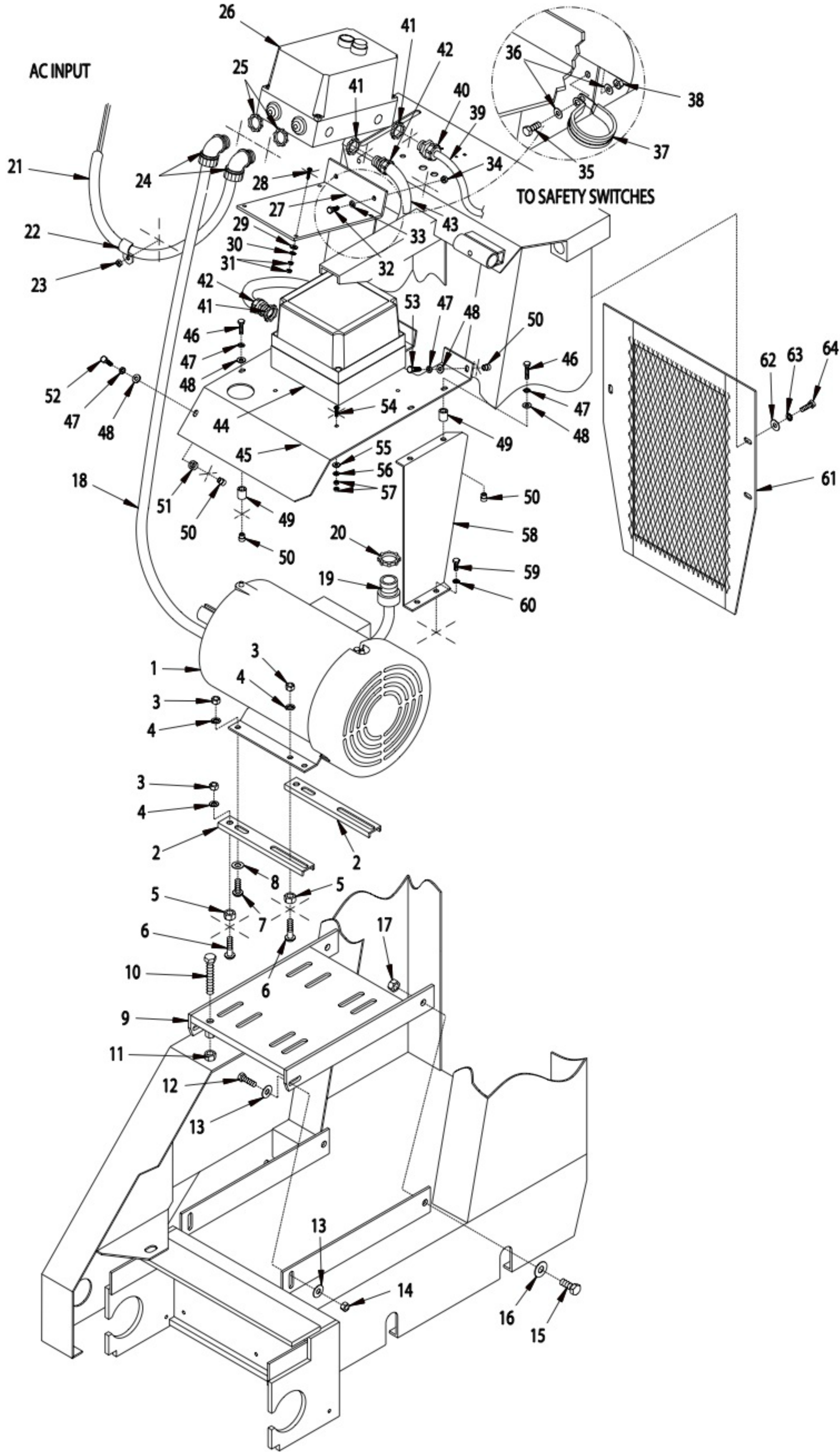

PARTS LISTING-ILLUSTRATION 7: ELECTRIC MOTOR GROUPING							
ITEM#	PART#	DESCRIPTION	QTY.	ITEM#	PART#	DESCRIPTION	QTY.
1	16004	MOTOR, BALDOR 10HP-3PH 60HZ 3450RPM	1	36	10602	WASHER, FLAT 1/4 SAE	2
2	64061	MOUNT BRKT., 10 HP BALDOR	2	37	11566	CLAMP, LOOM, 1-3/4" (SAE SIZE 28)	1
3	10404	NUT 3/8-16	6	38	10150	NUT, HEX NYLON LOCK 1/4-20	1
4	10811	WASHER, LOCK 3/8	6	39	64414	WIRE HARNESS 16/3 X 40"	1
5	10417	NUT 1/2-13	4	40	40066	STRAIN RELIEF 1/2NPT X .350-.450"	1
6	10804	BOLT, CARRIAGE 3/8-16 X 1-1/2 F.T.	4	41	10790	CONDUIT LOCK NUT 1/2 NP	3
7	10802	BOLT, CARRIAGE 3/8-16 X 1 FULL THD.	2	42	41130	STRAIN RELIEF 1/2NPT X .550-.650"	2
8	10040	WASHER, GARRET 17/32 X 1 X .054	2	43	64415	WIRE HARNESS 16/5 X 48"	1
9	64017	MOUNT, ENGINE/MOTOR	1	44	16500	TRANSFORMER W/ BOX COMPLETE	1
10	10340	BOLT, TAP 1/2-13 X 3 (FULL THREAD)	1			<i>REPLACEMENT PARTS INCLUDE:</i>	
11	10417	NUT 1/2-13	1		16150	TRANSFORMER 75VA 240/480P.V.-24S.V.	1
12	10309	SCREW, CAP 3/8-24 X 1-1/4 PLATED	2		16501	ENCLOSURE, NEMA 4X, 6.9 X 6.9 X 5.9	1
13	10025	WASHER, FLAT 3/8 SAE	4		16502	ENCLOSURE PANEL 5.8 X 5.8	1
14	10152	NUT, HEX NYLON LOCK 3/8-24	2		16504	FUSE, MIDGET 600VAC, 5AMP	1
15	10321	SCREW, CAP 1/2-20 X 1-1/4	2		16505	FUSE BLOCK, SINGLE POLE W/ BOX LUGS	1
16	10312	WASHER, FLAT 1/2 SAE	2		16506	SCREW, SHEET METAL 8 X 3/8 TRUSS HD	12
17	10154	NUT, HEX NYLON LOCK 1/2-20	2	45	64062	SHROUD, MOTOR	1
18	64412	WIRE HARNESS 10/4 X 66"	1	46	10905	SCREW, CAP 1/4-20 X 1-1/4	4
19	16172	STRAIN RELIEF 1"NPT X .625-.750"	1	47	10038	WASHER, LOCK 1/4	6
20	10770	CONDUIT LOCK NUT 1" NP	1	48	10602	WASHER, FLAT 1/4 SAE	6
21	64413	WIRE HARNESS 10/4 X 50"	1	49	52045	SPACER, STEEL 5/8OD X 3/8ID X 3/4L	4
22	41122	TREADLE, TRANSFER ARM	1	50	10439	THREAD-SERT 1/4-20, BLIND RIVET	6
23	10150	NUT, HEX NYLON LOCK 1/4-20	1	51	10011P	SPACER, PLTD. STL. 5/8OD X 3/8ID X 3/8	1
24	10984	CONN., LIQUID TITE 90D X 3/4NPT	2	52	10031	SCREW, CAP 1/4-20 X 1	1
25	10740	CONDUIT LOCK NUT 3/4 NP	2	53	10018	SCREW, CAP 1/4-20 X 3/4	1
26	16450	STARTER 11-M2-BRF-P32-33-02460 (230V)	1	54	10362	SCREW, MACHINE 8-32 X 3/4	4
	16447	STARTER 11-M2-BRF-P32-15-02460 (460V)	1	55	10875	WASHER, FLAT #8 SAE	4
27	64411	BRACKET, LOVATO STARTER	1	56	10461	WASHER, LOCK, INT. TOOTH #8	4
28	10362	SCREW, MACHINE 8-32 X 3/4	4	57	10462	NUT 8-32	8
29	10875	WASHER, FLAT #8 SAE	4	58	64063	SHROUD SIDE PANEL, MOTOR	1
30	10461	WASHER, LOCK, INT. TOOTH #8	4	59	10846	SCREW, CAP STSHW 1/4-20 X 1/2	2
31	10462	NUT 8-32	8	60	10038	WASHER, LOCK 1/4	2
32	10053	SCREW, CAP 5/16-18 X 3/4	2	61	64066	GRILLE, REAR	1
33	10213	WASHER, FLAT 5/16 SAE	4	62	10213	WASHER, FLAT 5/16 SAE	3
34	10807	NUT, LOCK 5/16-18	2	63	10801	WASHER, LOCK 5/16	3
35	10018	SCREW, CAP 1/4-20 X 3/4	1	64	10806	SCREW, CAP 5/16-18 X 1	3



ILLUSTRATION 8: BELT DRIVE GROUPING

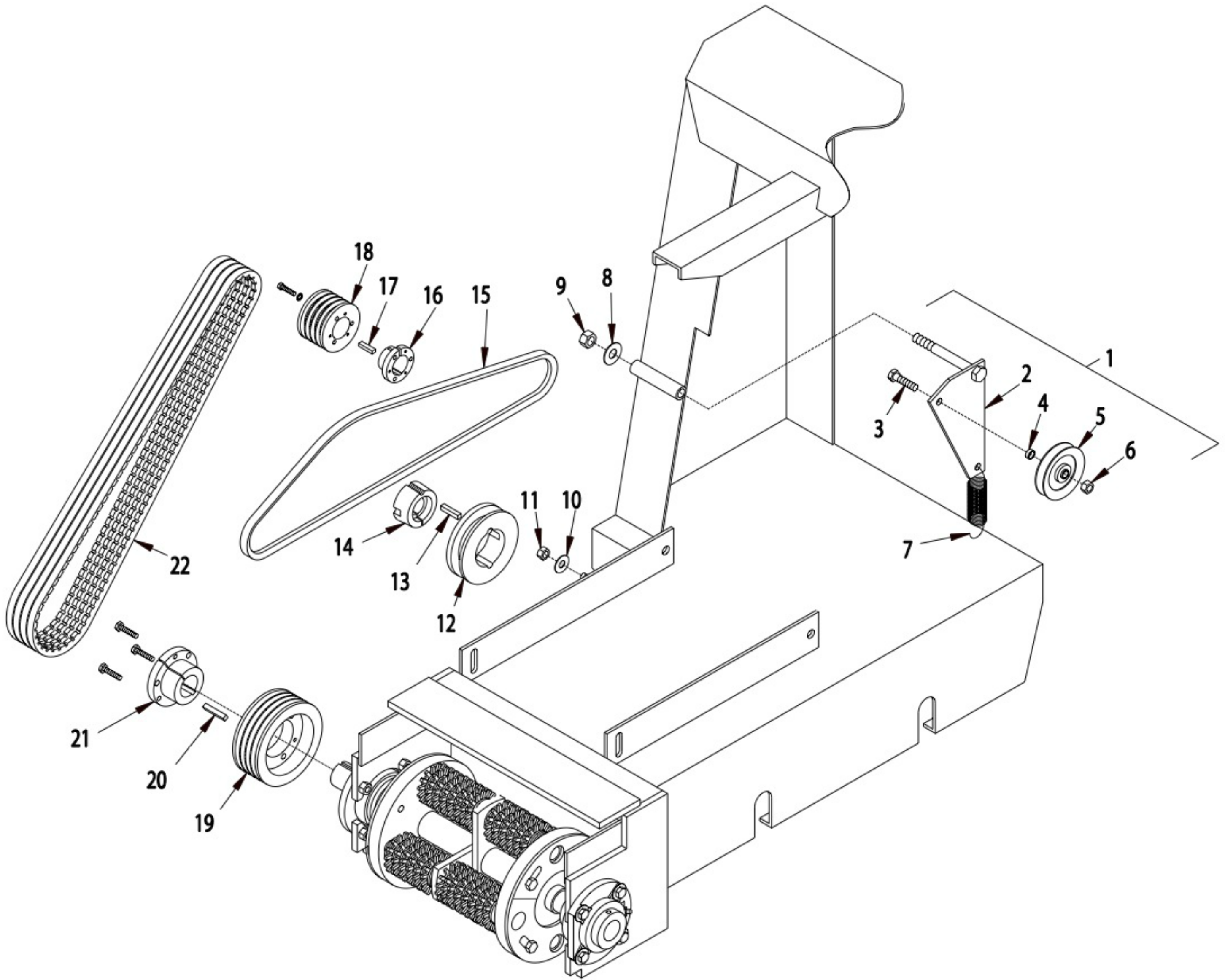

PARTS LISTING-ILLUSTRATION 8: BELT DRIVE GROUPING			
ITEM#	PART#	DESCRIPTION	QTY.
1	64019A	IDLER ARM SUBASSEMBLY (INCLUDES ITEMS 2-6)	1
2	64019	BRACKET, IDLER	1
3	10029	SCREW, CAP 3/8-24 X 1-3/4	1
4	10113	SPACER, STEEL 9/16" OD x 3/8" ID x 7/32"T	1
5	50115	PULLEY, IDLER 3"OD x 1GR.AB x 3/8" BRG.	1
6	10152	NUT, HEX NYLON LOCK 3/8-24	1
7	50074	SPRING, EXT. 1"OD x 3-15/16" INSIDE ENDS	1
8	10312	WASHER, FLAT 1/2	1
9	10155	NUT, HEX NYLON LOCK 1/2-13	1
10	10025	WASHER, FLAT 3/8	1
11	10156	NUT, HEX NYLON LOCK 3/8-16	1
12	10528	SHEAVE, 4.15"OD x 1GR.AB x TAPER LOCK	1
13	10305	KEY 1/4" SQUARE x 1-1/4"L	1
14		BUSHING, SHEAVE TAPER LOCK	1
	10529A	1-1/8" WITH COUNTERBORE (20HP HONDA)	
	10544	1" BORE (13HP HONDA)	
	10529	1-1/8" BORE (12HP KOHLER)	
	10537	1-3/8" BORE (10HP BALDOR)	
15		BELT	1
	10218	4L-450 (HONDA, 12HP KOHLER COMMAND, BALDOR)	
	10240	AP-44(20HP KOHLER COMMAND)	
16		BUSHING, SHEAVE JA	1
	10533	1-1/8" BORE (20HP HONDA)	
	10557	1" BORE (13HP HONDA)	
	10533	1-1/8" BORE (12HP KOHLER)	
	*	NO BUSHING FOR 10HP BALDOR	
17	10118	KEY, 3/8"SQ. x 2-1/4	1
18		SHEAVE	1
	64037	2.8"OD x 4Gr.3V x JA (13/20HP HONDA & 12HP KOHLER)	
	64069	3"OD x 4 Gr.3V x 1-3/8" BORE (10HP BALDOR)	
19	64038	SHEAVE 4.75"OD x 4GR. 3V x SDS	1
20	10305	KEY 1/4" SQ. x 1-1/4" L	1
21	10064	BUSHING, SHEAVE SDS x 1-1/4" BORE	1
22	10235	BELT 3VX-475	4



100 Thomas Johnson Drive, Frederick, MD 21702-4600 USA

Phone (301) 663-1600 • 1-800-638-3326

Fax (301) 663-1607 • 1-800-447-3326

Website: www.edcoinc.com • Email: sales@edcoinc.com

Printed in USA

©2006

Page 19

ILLUSTRATION 9: DRUM BEARING & AXLE GROUPING

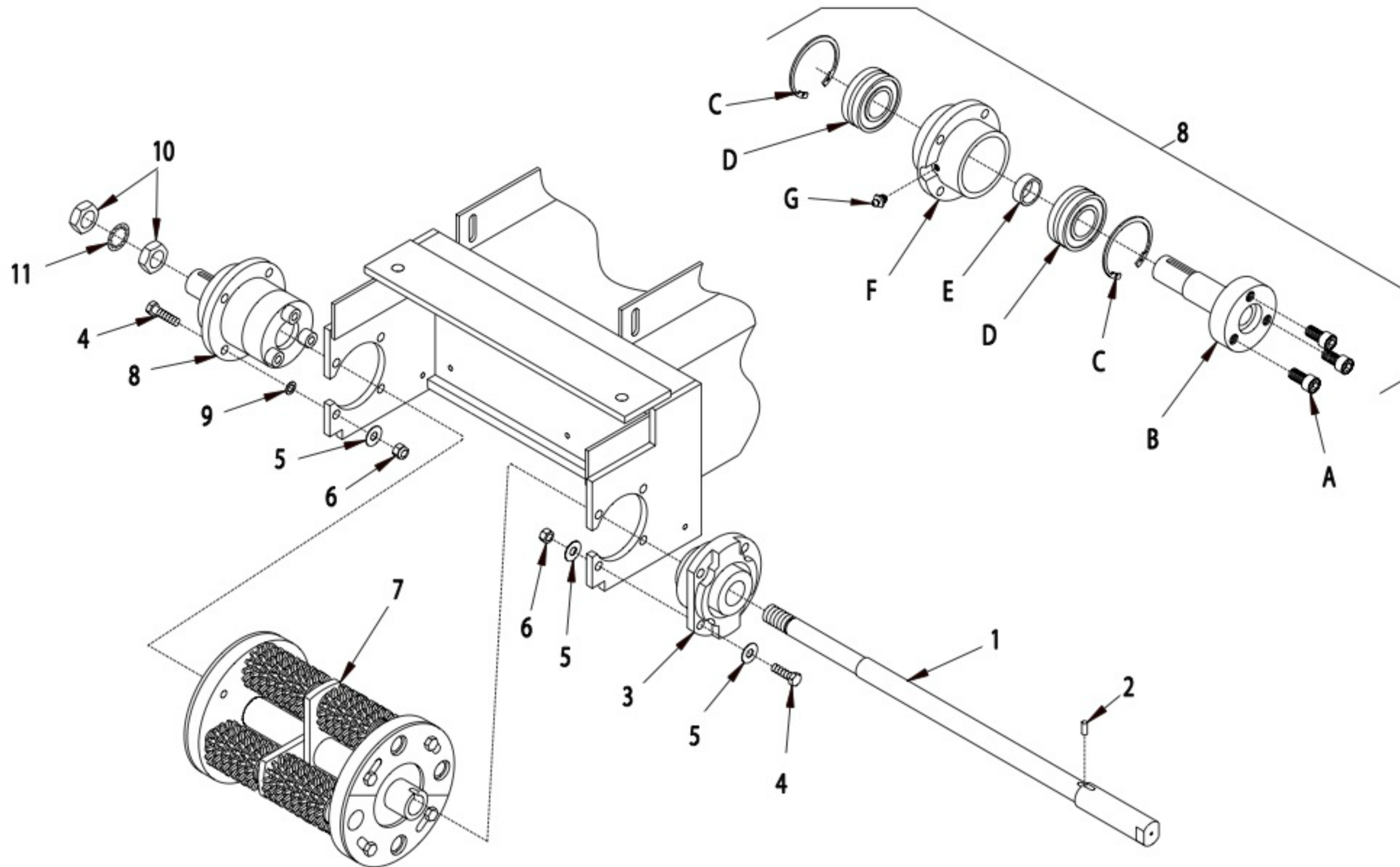

ITEM#	PART#	DESCRIPTION	QTY.
1	64410	SPINDLE SHAFT 24"	1
2	64162	PIN, DOWEL 1/4 x 5/8(.002 OVERSIZED)	1
3	84082R	BEARING, ROLLER 1-1/4 PILOT 4-HOLE NOTE: SET SCREW COLLAR REMOVED	1
4	10816	SCREW, CAP 3/8-24 x 1-1/2	8
5	10025	WASHER, FLAT 3/8	12
6	10152	NUT, HEX NYLON LOCK 3/8-24	8
7		CUTTER WHEEL DRUM ASSEMBLY COMPLETE	1
	64420	4 SHAFT CUTTER DRUM (REFER TO ILLUS. 10)	
	64430	6 SHAFT CUTTER DRUM (REFER TO ILLUS. 11)	
8	64160	BEARING & DRIVER ASSEMBLY COMPLETE	1
A	10490	SCREW, SOCKET HEAD CAP 1/2-13 x 1	3
B	64155B	HUB WITH SHAFT, DRIVE	1
C	64154	RETAINING RING, INTERNAL 2-3/16"	2
D	64152	BEARING, ROLLER 35mm x 72mm x 23mm	2
E	64153	SPACER, BEARING CENTER	1
F	64151	HOUSING, BEARING	1
G	10953	FITTING, GREASE 1/8 NPT STRAIGHT	1
9	64159	SHIM 3/8"ID x 5/8"OD x .031"THK. (USE WHEN REQ'D)	2
10	10445	NUT, JAM 7/8-9 LEFT HAND THREAD	2
11	64158	WASHER, INT. TOOTH 7/8	1

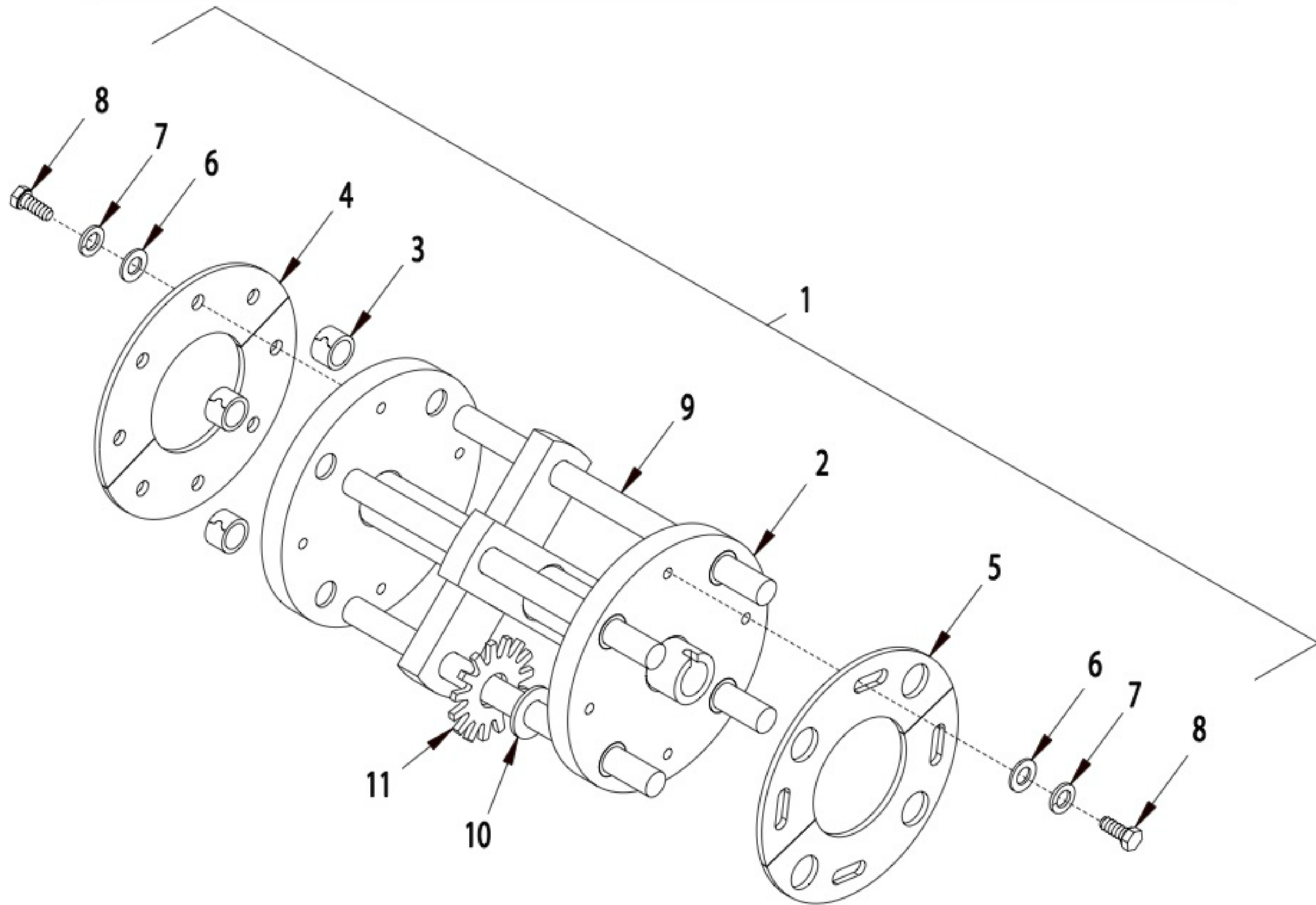
ILLUSTRATION 10: STANDARD 4-SHAFT CUTTER DRUM GROUPING

ITEM#	PART#	DESCRIPTION	QTY.
1	64420	DRUM ASSEMBLY COMPLETE, 4 SHAFT (INCLUDES ITEMS 2-9)	1
2	64421	DRUM ONLY, 4-SHAFT	1
3	84063	BUSHING, DRUM, HARDENED STEEL 3/4" ID	8
4	64203	RETAINING PLATE (2-HALVES) 7-3/8"	1
5	64204	LOCKING PLATE (2-HALVES) 7-3/8"	1
6	10025	WASHER, FLAT 3/8	8
7	10811	WASHER, LOCK 3/8	8
8	10912	SCREW, CAP 3/8-16 x 7/8 (GRADE 8)	8
9	20120	CP406B SHAFT 3/4 X 11-3/8	4
10	20060	CP403 SPACER 1-1/2" OD x 3/4" ID	*
11		CUTTER WHEEL	*
	20136	CP408TV CUTTER WHEEL, 3-1/8" CARBIDE, 1-3/16" HOLE	
	20056	CP405P CUTTER WHEEL, 3" POINTED	
	20086	CP405 CUTTER WHEEL, 3" FLAT TOOTH	
<p>*NOTE: CUTTER WHEELS AND SPACERS ARE NOT INCLUDED WITH THE DRUM ASSEMBLY. THE NUMBER OF CUTTER WHEELS AND SPACERS VARY WITH THE TYPE OF SET UP USED. REFER TO ASSEMBLY INSTRUCTIONS FOR SUGGESTED SET UPS AND QUANTITIES.</p>			

ILLUSTRATION 11: OPTIONAL 6-SHAFT CUTTER DRUM GROUPING
--

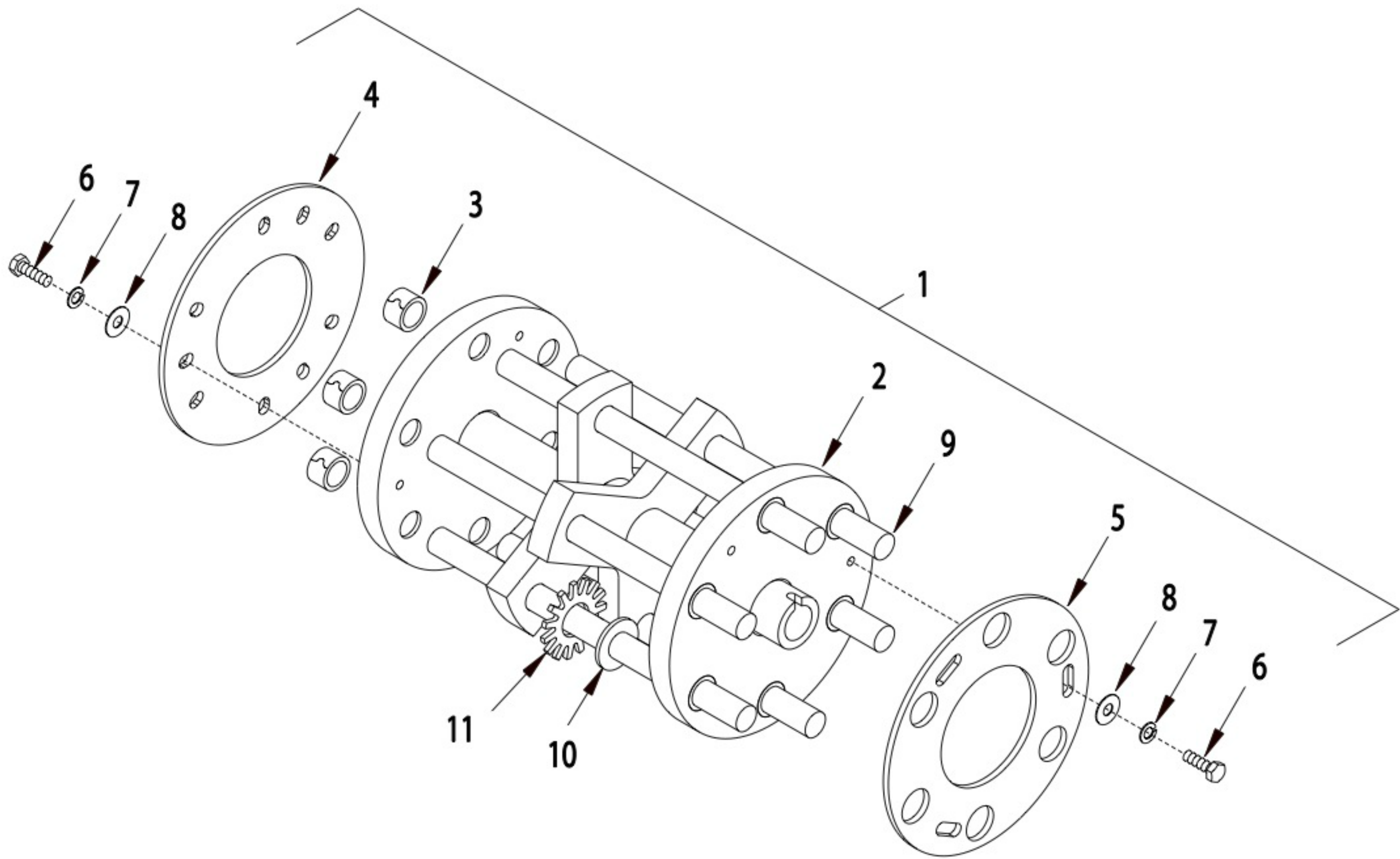

ITEM#	PART#	DESCRIPTION	QTY.
1	64430	DRUM ASSEMBLY COMPLETE, 6-SHAFT (INCLUDES ITEMS 2-9)	1
2	64431	DRUM ONLY, 6-SHAFT	1
3	84063	BUSHING, DRUM, HARDENED STEEL 3/4" ID	12
4	64253	RETAINING PLATE, 6-SHAFT DRUM	1
5	64254	LOCKING PLATE, 6-SHAFT DRUM	1
6	10806	SCREW, CAP 5/16-18 x 1	6
7	10801	WASHER, LOCK 5/16	6
8	10213	WASHER, FLAT 5/16	6
9	20120	CP406B SHAFT 3/4 X 11-3/8	6
10	20060	CP403 SPACER 1-1/2" OD x 3/4" ID	*
11		CUTTER WHEEL	*
	20326	CP308T CUTTER WHEEL, 2-1/4 CARBIDE	
	20076	CP404 CUTTER WHEEL, 2-3/8" FLAT TOOTH, 1" HOLE	
	20296	CP404-P6 CUTTER WHEEL, 2-3/8" POINTED, 3/4" HOLE	
<p>*NOTE: CUTTER WHEELS AND SPACERS ARE NOT INCLUDED WITH THE DRUM ASSEMBLY. THE NUMBER OF CUTTER WHEELS AND SPACERS VARY WITH THE TYPE OF SET UP USED. REFER TO ASSEMBLY INSTRUCTIONS FOR SUGGESTED SET UPS AND QUANTITIES.</p>			

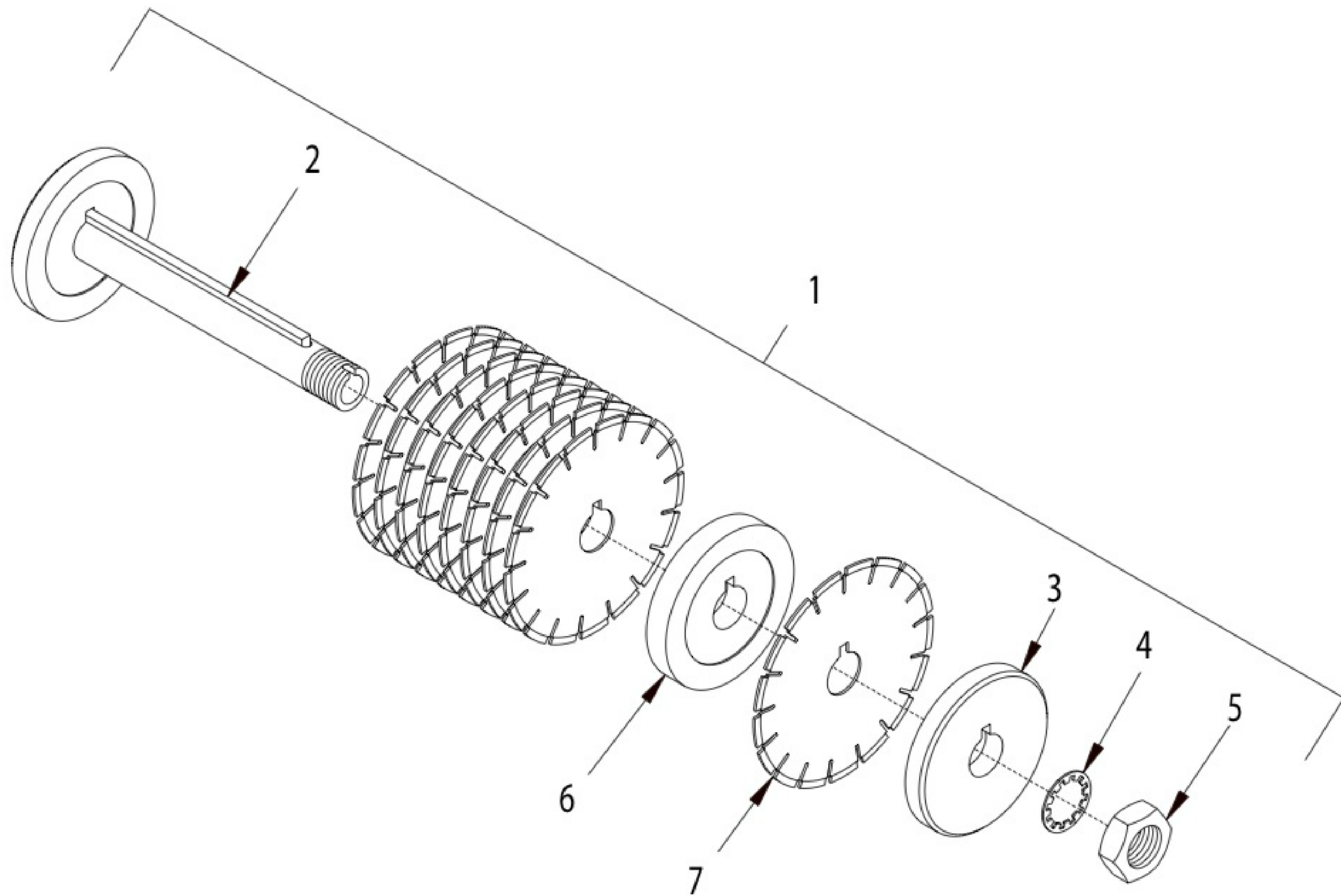
ILLUSTRATION 12: OPTIONAL DIAMOND GROOVING HEAD GROUPING

ITEM#	PART#	DESCRIPTION	QTY.
1	64440	DIAMOND GROOVING HEAD ASSEMBLY (INCLUDES ITEMS 2-5)	1
2	64441	ARBOR, DIAMOND GROOVING HEAD	1
3	64303	ARBOR, BLADE RETAINING CAP 6"	1
4	64304	WASHER, LOCK, INT. TOOTH 1-1/2	1
5	64305	NUT, JAM 1-1/2-12	1
6		SPACER, BLADE	*
	64306	6" OD x 1-1/2" ID x .063" THK	
	64307	6" OD x 1-1/2" ID x .430" THK	
	64308	6" OD x 1-1/2" ID x .930" THK	
	64309	6" OD x 1-1/2" ID x 3/4" THK	
7		DIAMOND BLADE	*
	39807	8" DIA. x .090" THK x 1.5" w/KEYWAY DCC-05S	
	39810	8" DIA. x .250" THK x 1.5" w/KEYWAY DCC-05S	
	39850	8" DIA. x .250" THK x 1.5" w/KEYWAY (GRANITE)	
	39851	8" DIA. x .125" THK x 1.5" w/KEYWAY (C-OE-8)	
*NOTE: DIAMOND BLADES AND SPACERS ARE NOT INCLUDED WITH HEAD ASSEMBLY. THE QUANTITIES VARY WITH THE TYPE OF SET UP USED.			

LIMITED EQUIPMENT WARRANTY

Equipment Development Company, Inc. herein referred to as EDCO warrants that each new unit manufactured by EDCO to be free from defects in material and workmanship in normal use and service for a period of (1) one year (except in the case of the cutter drum assembly on all model concrete asphalt planes, in which case the warranty period shall be 90 days) from date of shipment to the original buyer or equipment rental center owner.

EDCO will, at its option, repair or replace, at the EDCO factory or at a point designated by EDCO any part, which shall appear to the satisfaction of EDCO inspection to have been defective in material or workmanship.

This warranty, does not apply to failure occurring as a result of abuse, misuse, negligent repairs, corrosion, erosion, normal wear and tear, alterations or modifications made to the product without express written consent of EDCO: or failure to follow the recommended operating practices and maintenance procedures as provided in the products operating and maintenance manuals.

This warranty does not obligate EDCO to bear any transportation charges in connection with the replacement or repair of defective parts. This warranty does not obligate EDCO to bear any expense for travel time or of personnel in connection with any service calls.

Accessories or equipment furnished and installed on the product by EDCO but manufactured by others, including but not limited to engines, motors, electrical equipment, transmissions, etc., shall carry the accessory manufacturers' own warranty.

THIS WARRANTY IS IN LIEU OF ALL OTHER WARRANTIES, EXPRESSED OR IMPLIED, OR STATUTORY, INCLUDING ANY WARRANTIES OF MERCHANTABILITY OR OF FITNESS FOR A PARTICULAR PURPOSE.

LIABILITY LIMITATIONS

The remedies of the user set forth under provisions of warranty outlined above are the exclusive and total liability of EDCO with the respect to their sale or the equipment and service furnished hereunder, in connection with the performance or breach thereof, or from the sale, delivery, installation, repair or technical direction covered by or furnished under the sale, whether based on contract, warranty, negligence, indemnity, strict liability, or otherwise shall not exceed the purchase price of the unit of equipment upon which such liability is based.

EDCO will not in any event be liable to the user, any successors in interest or any beneficiary or assignee relating to this sale for any consequential, incidental, indirect, special or punitive damages arising out of this sale or any breach thereof, or any defects on, or failure of, or malfunction of the equipment under this sale based upon loss of use, lost profits or revenue, interest, lost goodwill, work stoppage, impairment of other goods, loss by reason of shutdown or non-operation, increased expenses of operation of the equipment, cost of purchase or replacement power of claims of users or customers of the user for service interruption whether or not such loss or damage is based on contract, warranty, negligence, indemnity, strict liability, or otherwise.

EDCO reserves the right to modify, alter and improve any part or parts without incurring any obligation to replace any part or parts previously sold without such modified, altered or improved part or parts.

No person is authorized to give any other warranty or to assume any additional obligation on EDCO's behalf unless made in writing and signed by an officer of EDCO.

Equipment Development Company, Inc.

USE ONLY GENUINE EDCO PARTS AND ACCESSORIES

For your own safety, the safety of others and the life of your machine



ITEM	PART #	DESCR.
1	15138	METER
2	10887	SWITCH
3	10992	SWITCH
4	10970	CONN.
5	84011	BATTERY
6	50117R	CABLE
7	50117B	CABLE
8	15147	SWITCH
9	15148	SWITCH
10	15149	SWITCH

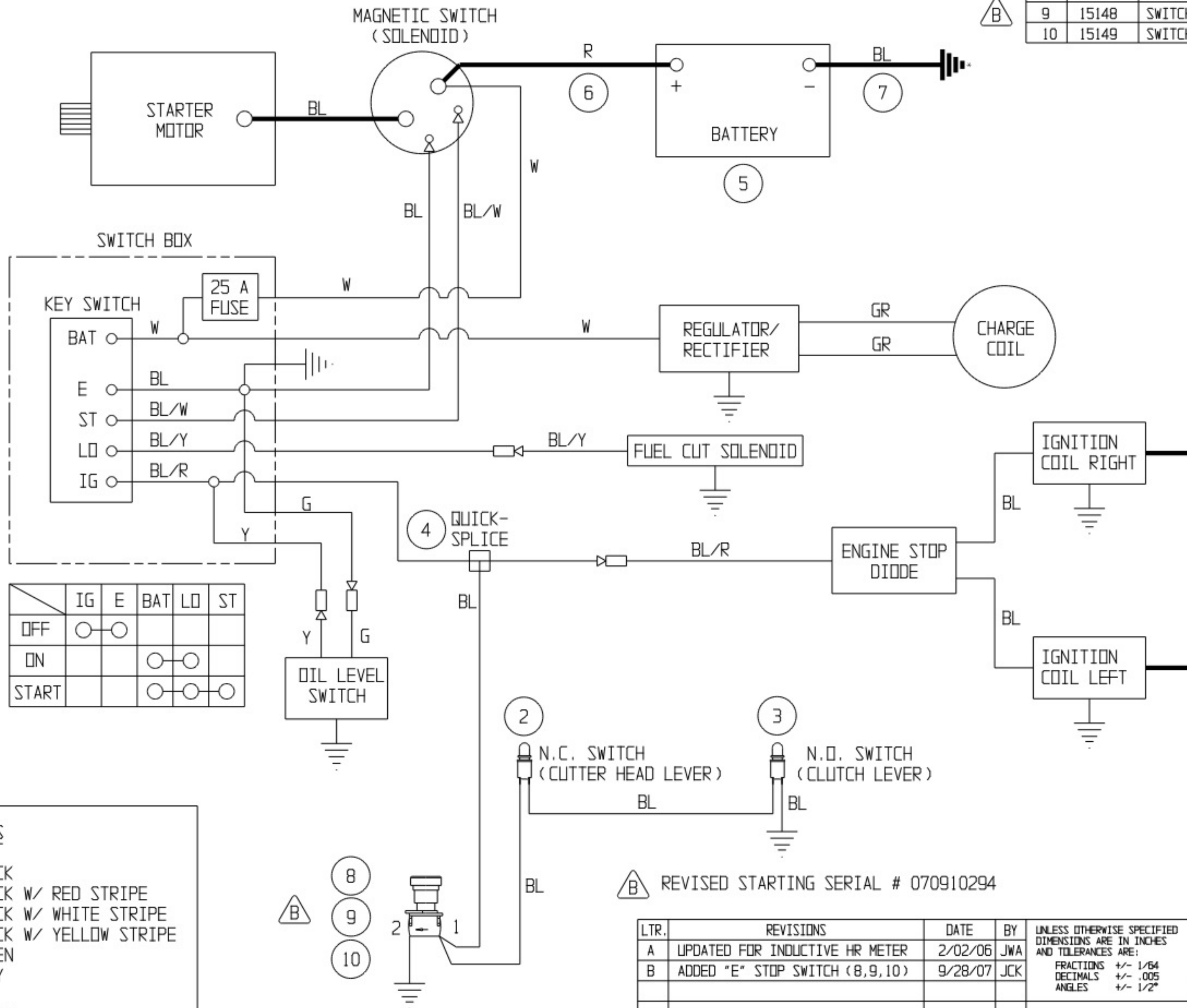

COLOR CODES

BL = BLACK
 BL/R = BLACK W/ RED STRIPE
 BL/W = BLACK W/ WHITE STRIPE
 BL/Y = BLACK W/ YELLOW STRIPE
 G = GREEN
 GR = GRAY
 R = RED
 W = WHITE
 Y = YELLOW
 Y/BL = YELLOW W/ BLACK STRIPE

REVIS B REVISED STARTING SERIAL # 070910294

LTR.	REVISIONS	DATE	BY	UNLESS OTHERWISE SPECIFIED DIMENSIONS ARE IN INCHES AND TOLERANCES ARE:
A	UPDATED FOR INDUCTIVE HR METER	2/02/06	JWA	FRACTIONS +/- 1/64 DECIMALS +/- .005 ANGLES +/- 1/2°
B	ADDED "E" STOP SWITCH (8,9,10)	9/28/07	JCK	

THE INFORMATION CONTAINED IN THIS DRAWING IS PROPRIETARY WITH EDCO AND MAY NOT BE USED OR REPRODUCED WITHOUT WRITTEN CONSENT.

ITEM	PART #	DESCRIPTION	QTY.	ITEM	PART #	DESCRIPTION	QTY.
1	15138	HOUR METER, INDUCTIVE	1	7	15148	SWITCH CLIP ONLY, E-STOP 333E	1
2	10992	SWITCH, PUSHBUTTON, N.O. MOMENTARY	1	8	15167	SWITCH CONTACT BLOCK, N.C. 33E01	1
3	10997	BOOT, RED RUBBER, 15/32-32 THREAD	1	9	84011	BATTERY 12 VOLT/300 CCA (SMALL ENG.)	1
4	10887	SWITCH, PUSHBUTTON, N.C. MOMENTARY	1	10	50117R	CABLE, EYE-EYE 4GA. X 24" (RED)	1
5	10674	BOOT, TOGGLE SWITCH	1	11	50117B	CABLE, EYE-EYE 4GA. X 24" (BLACK)	1
6	15147	SWITCH PUSHBUTTON ONLY, E-STOP	1				

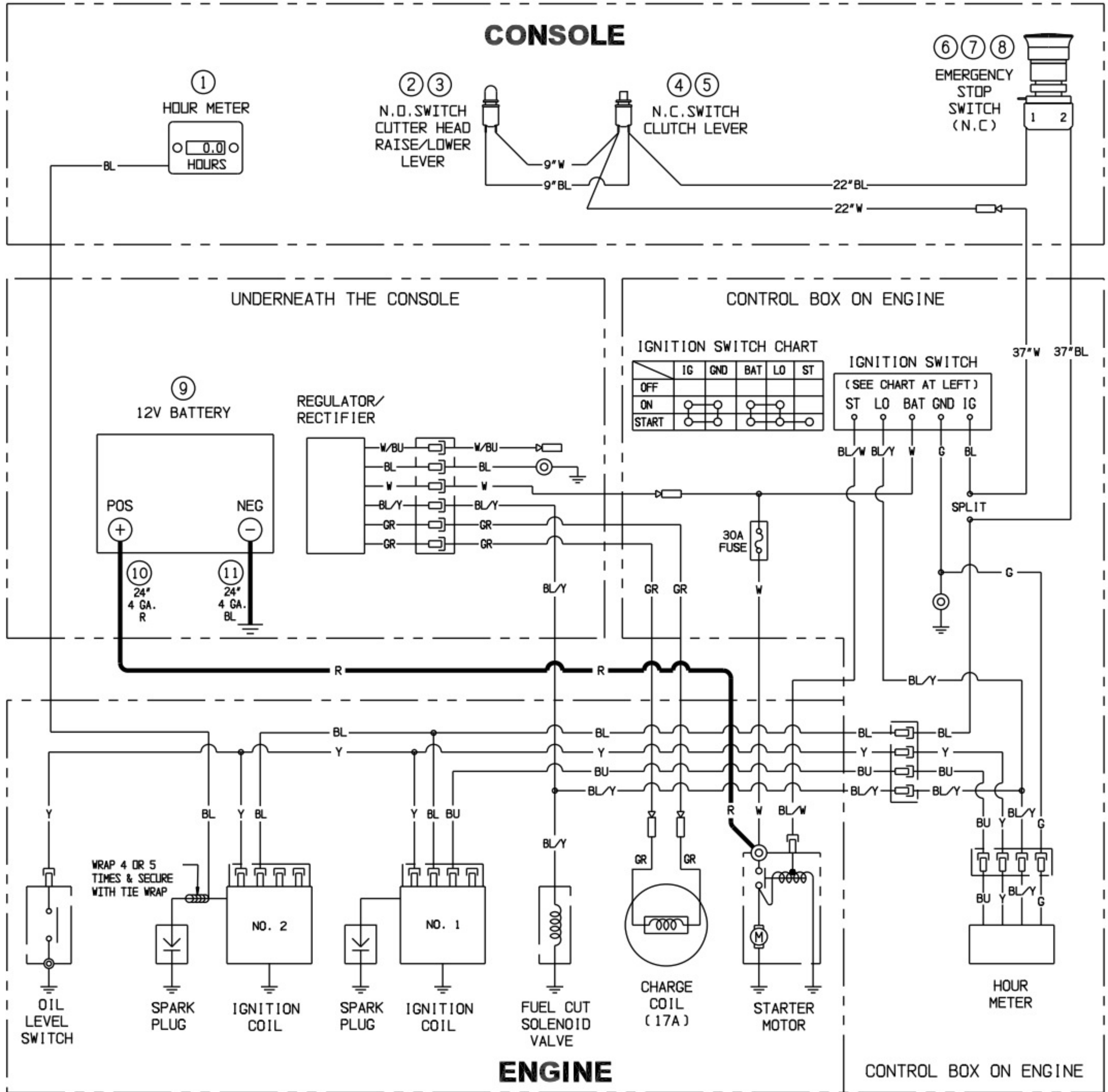

WIRING DIAGRAM FOR MODEL CPU 10FC-20H WITH HONDA GX630 ENGINE

STARTING SERIAL NUMBER 110410231

COLOR CODES

BL = BLACK
 BU = BLUE
 G = GREEN
 GR = GRAY
 R = RED
 W = WHITE
 Y = YELLOW
 BL/W = BLACK / WHITE STRIPE
 BL/Y = BLACK / YELLOW STRIPE
 W/BU = WHITE / BLUE STRIPE

LTR.	REVISIONS	DATE	BY
A	ADDED WIRE LENGTHS AND ADDED RUBBER BOOTS FOR SWITCHES	6/14/12	JWA

UNLESS OTHERWISE SPECIFIED
DIMENSIONS ARE IN INCHES
AND TOLERANCES ARE:
FRACTIONS +/- 1/64
DECIMALS +/- .005
ANGLES +/- 1/2°

THE INFORMATION CONTAINED IN
THIS DRAWING IS PROPRIETARY
WITH EDCO AND MAY NOT BE
USED OR REPRODUCED WITHOUT
WRITTEN CONSENT.

EQUIPMENT DEVELOPMENT CO., INC.

MODEL(S) CPU10FC-20H PART #

TITLE **WIRING DIAGRAM**

DWG. REV. A

DWN. BY JWA DATE 4/19/11 DWG. # 18645

CHK. BY JWA PLOT SCALE .2 DWG. SIZE C