

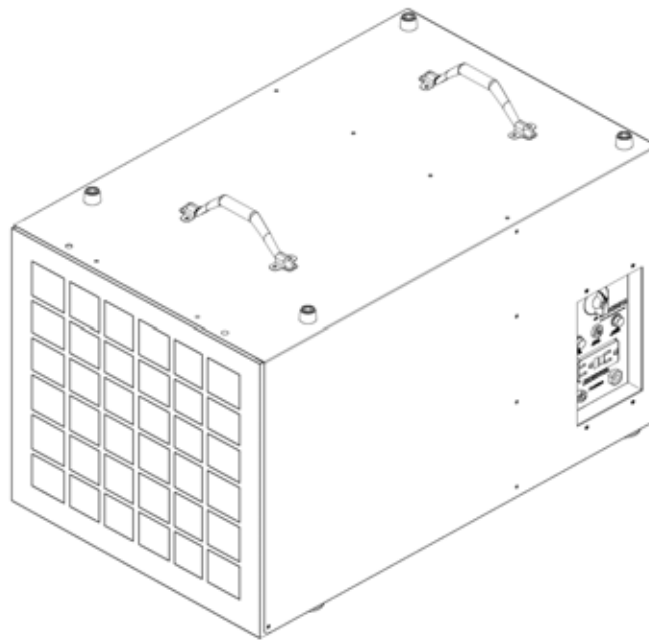

## HEPA-AIRE PORTABLE AIR SCRUBBER-PAS600

### INSTRUCTIONAL MANUAL



**Abatement Technologies, Inc./Remediation Products Division**

**Abatement Technologies, Inc.**  
Georgia, USA  
800-634-9091

**Abatement Technologies Ltd.**  
Ontario, Canada  
905-871-4720

# THE HEPA-AIRE® PORTABLE AIR SCRUBBER

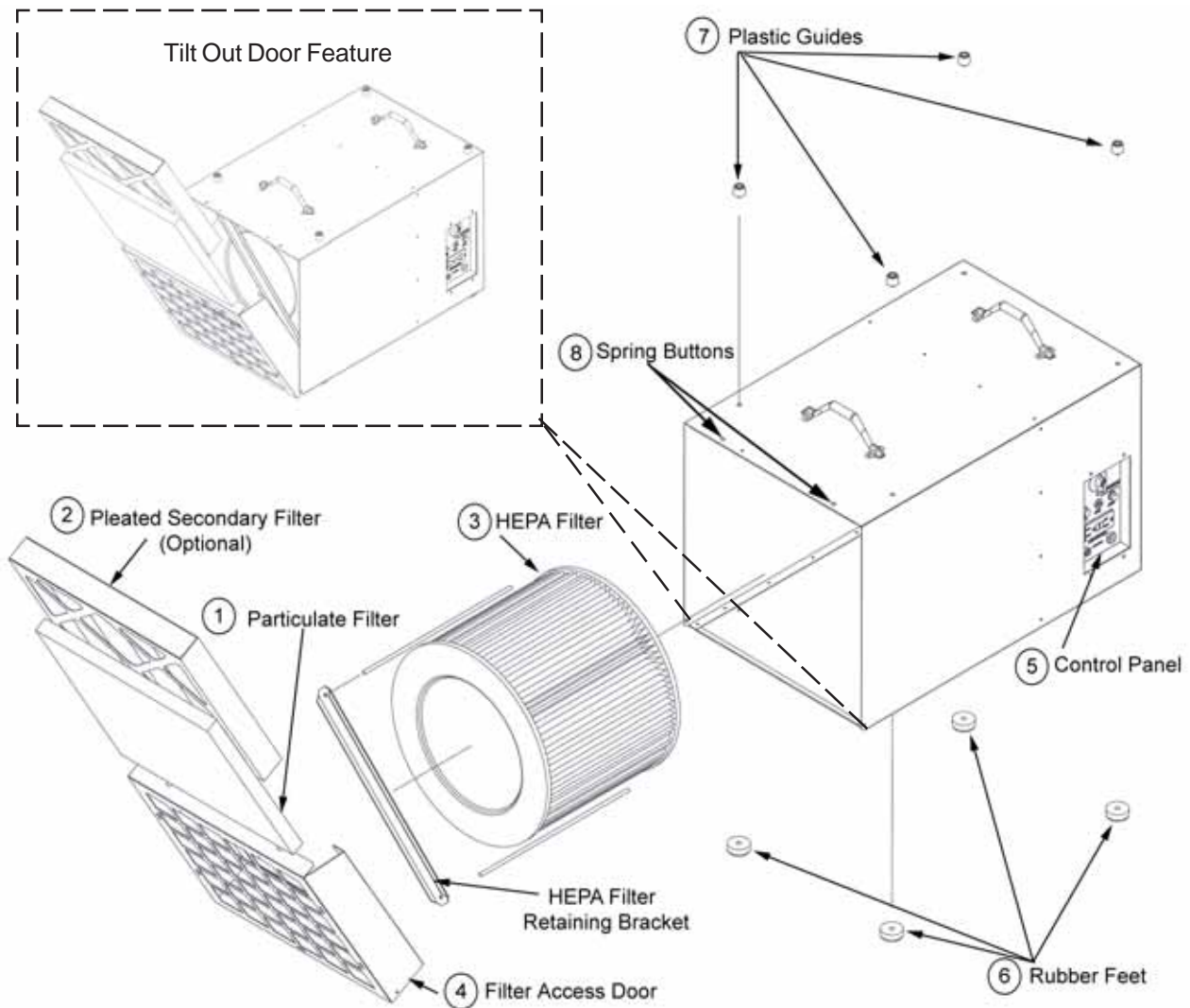

1. First Stage - 1" Coarse/Particulate Prefilter (P/N F621) prevents the premature loading of the HEPA filter by removing large particles.
2. Second Stage - 2" particulate/carbon filter (P/N VL602). For additional odor/vapor/gas adsorption, an optional activated carbon filter (P/N VL1002, not provided with unit) can be used in place of the VL602.
3. Final Stage - High Efficiency Particulate Air (HEPA) filter (P/N H610C-99) which is 99.97% efficient against 0.3 micron size particles.
4. Filter Access Door
5. Control Panel
6. Rubber Feet
7. Plastic Guides
8. Spring Buttons - Push to open filter access door.

# HEPA-AIRE® PORTABLE AIR SCRUBBER - PAS600

© Abatement Technologies 2003 All Rights Reserved. No reproduction of any portion of this work is permitted without the express written permission of Abatement Technologies, Inc.

## Note:

1. **Read and understand all operating instructions before using the PAS600 Portable Air Scrubber.**
2. **Save this manual for future reference.**

This instruction manual provides important information on the use of the HEPA-AIRE Portable Air Scrubber PAS600 unit. These instructions must be carefully followed in order to operate the unit safely and correctly. If there are any questions regarding the use of the unit, please contact Abatement Technologies, Inc. immediately at 800-634-9091 U.S. or 905-871-4720 Canada.

## GENERAL INFORMATION

The PAS600 is a multi-use air filtration device capable of filtering most airborne particulates and odors, vapors, and gases (O/V/G).

Types of contaminants captured:

- Dirt
- Dust
- Drywall Dust
- Saw Dust
- Lung-Damaging Particles
- Metal Fumes
- Smoke
- Molds and Fungi
- Gases
- VOC
- Unpleasant Odors

The PAS600 provides particulate and odor/vapor/gas filtration with final stage filtration through a High Efficiency Particulate Air (HEPA) filter.

### **The PAS600 is designed for indoor operation only.**

The PAS600 is engineered for easy transport to and around the project site. The bottom panel of the PAS600 is equipped with 4 rubber feet and the top panel has 4 plastic guides. The rubber feet on the bottom panel are larger than the guides on the top panel to make stacking of PAS units easier. The PAS600 incorporates a series of particulate filters which successively remove larger size to smaller size particles from the air.

An activated carbon filter is used to adsorb odors, vapors and gases. The process of adsorption retains the O/V/G molecules within the pores of the carbon granules.

Effective removal of various odors, vapors, and gases relies on the removal of the emission source, and the air-scrubbing of the ambient air containing the airborne O/V/G contaminants. By recirculating the ambient air within the project area, the air is filtered and returned to mix with the rest of the room air.

The PAS600 is equipped with a variable speed control switch and filters between 100-600 cubic feet of air per minute with clean filters and without the attachment of flexible duct. As a guide, the following formula may be used when calculating the total air recycling time (one air change) in a closed environment (assuming no intake of additional air):

$$\frac{\text{Volume of enclosed area (cubic feet)}}{\text{CFM of PAS600}} = \text{Number of minutes required to filter the area air through the PAS600 one time.}$$

EXAMPLE:  $\frac{\text{Room size of 20'L x 20'W x 12'H= 4800 cu.ft.}}{600 \text{ cu.ft. min.}} = \frac{8 \text{ min. for 1 air change}}{7.5 \text{ air changes per hour}}$

Effective carbon filtration is dependent upon the amount of contact time that the O/V/G molecules have with the carbon filter media. As the PAS600 draws air through the media, the air is "scrubbed" as these molecules adhere to the surfaces of the carbon granules. There is no "rule of thumb" for determining the length of time required for an area to be cleaned of ambient odors, vapors, or gases. Unknown variables such as concentration, intake volume of fresh air, temperature, humidity, and other factors prevent the accurate estimation of carbon filter life. For odorous substances, the evidence of a clean, air-scrubbed environment is the absence or greatly reduced presence of the O/V/G. Air quality testing should be conducted if the source is unknown, the vapors are toxic and/or otherwise hazardous to health, and to confirm that substances are not present at harmful levels.

## PAS600 OPERATION

**Note: To maximize the unit's airflow performance, always use the shortest length of flexible duct necessary. This applies to flex duct connected to the inlet. Use of excess flex duct will dramatically reduce machine airflow. The flexible duct should be as straight as possible (to avoid airflow loss from bends).**

In the PAS600, each filter contributes to the total filtering efficiency of the system. The incoming air passes through a 1" thick first stage prefilter (F621). Large particles are retained by this filter, and the air then passes through a 2" thick second stage carbon impregnated filter (VL602) which removes finer particulates and odors, vapors and gases. The second stage filter slot can be used for an optional high capacity carbon filter (VL1002) pack for higher concentrations of odors, vapors, and gases. See chart at the end of this manual entitled "Activated Carbon Adsorbency of Selected Substances and Odors." The air then passes through the final stage HEPA filter which captures 99.97% of all particles 0.3 microns and larger in size.

## ELECTRICAL REQUIREMENTS

- 1. For maximum safety, the PAS600 should always be connected to a three-prong grounded 115 volt/15 amp electrical outlet equipped with a Ground Fault Circuit Interrupter (GFCI) device. To reduce risk of fire or electrical shock, do not use the PAS600 with any solid state speed control device. Do not use in a cooking area.**

**Caution:** To avoid damage to the PAS600 electrical system and power cord, do not connect or disconnect a power cord to an electrical outlet unless speed control switch is in the "OFF" position.

2. All electrical equipment used on the job must be in good condition and properly grounded. Check all outlets, wiring, extension cords, and the ground pin on plugs.

3. Extension cords used for the PAS600 must be the heavy duty No. 14/3 AWG industrial grade 3-wire type, in good condition and in continuous lengths (no splicing). Power cords should not exceed a total of 50' in length.

**Caution:** The HEPA-AIRE PAS600 requires a minimum of 110 volts to operate properly. Make certain that any extension cords used do not reduce power to the machine to less than 110 volts. Use of a voltmeter to confirm adequate voltage is recommended.

4. Due to momentary start-up current surge, the unit requires a 15 amp circuit which is free of other loads.

### **REQUIREMENTS FOR SAFE OPERATION**

1. Never allow unauthorized individuals or children to operate the unit at any time.
2. Abatement Technologies urges anyone operating the PAS600 to wear the proper personal protective equipment in accordance with federal, state and employer regulations.
3. Check condition of power cord(s) before using them. Damaged cords can cause fatal electrical shock and/or motor failure.
4. As with any piece of electrical equipment, be sure that the unit's Speed Control Switch is "OFF" prior to connecting the power cord to an electrical outlet. Failure to do so will cause "arcing" and damage unit. Never pull on an energized power cord to disconnect it from an outlet.
5. Do not touch the electrical outlet or power cord(s) with wet hands or while standing on a wet or damp surface.
6. Power cord(s) should never be exposed to water, heat, sharp, or abrasive objects; in addition, they should never be kinked or crushed.
7. Never pull the unit by the power cord.
8. Avoid running over power cords with utility equipment and vehicles.
9. Avoid tightly wrapping the cords to prevent kinking of the internal wires.
10. Always replace damaged cords immediately.

**Warning: To reduce risk of electrical shock, do not expose this unit to water or rain.**

**Warning: Risk of electrical shock! Can cause injury or death. Turn unit "OFF" and disconnect power cord before servicing unit.**

**CAUTION: For General Ventilating Use Only. Do not use to exhaust Hazardous Or Explosive Materials And Vapors.**

**Warning:** Any atmosphere that is combustible, flammable, explosive, oxygen deficient, and/or contains odors, vapors, gases or particulates that exceed permissible exposure levels should be evaluated by a certified industrial hygiene professional before being occupied. Such atmospheres may require the use of intrinsically safe equipment, specific engineering controls, and personal protective equipment in accordance with Occupational Safety and Health Administration (OSHA), Environmental Protection Agency (EPA), Canadian Standards Association (CSA), and other federal, state, provincial and local regulations.

**Warning:** This equipment is not classified as “intrinsically safe” and should not be used in the following potentially hazardous locations as defined by the Underwriters Laboratories: Class I Division I, Class I Division 2, Class 1 Zone 0, Class 1 Zone 1, Class 1 Zone 2, Class II Division 1, Class II Division 2, Class III Division 1, Class III Division 2. Refer to the UL web site: <http://www.ul.com/hazloc/define.htm>.

**BEFORE OPERATING THE UNIT NOTE THE FOLLOWING:**

Inspect and tighten any HEPA filter retaining bolts that may have loosened during transportation. Inspect each filter for any material or structural damage prior to each use. Replace any damaged filters before operating the PAS600. When removing any filters prior to operation, always replace with air flow indicator on filter housing oriented in the proper direction (if applicable).

**PAS600 CONTROL PANEL**

1. **Power Cord** - Hard-wired, 10 foot power cord for connection to electrical outlet.
2. **Speed Control Switch** - Serves as the power switch and provides a variable adjustment to the speed of the motorized impeller.
3. **Power Indicator** - Green light which indicates speed control switch is "ON" and system is energized.
4. **Filter Change Indicator** - Indicates blocked intake or excessive loading of the prefilters and that filter change procedures should be followed. Check the Filter Change Indicator when the unit is operating at "HIGH" speed.
5. **Circuit Breaker** - 5 amp circuit breaker provides protection for the unit's electrical components.
6. **GFCI Receptacle** - Electrical safety device that will trip and stop the flow of electricity if leakage of current is detected. The PAS600 can supply a total of 10 amps of electrical power for additional equipment that is connected to the GFCI receptacle.

**Note:** If the equipment connected to the GFCI receptacle draws more than a total of 10 amps, the circuit breaker on the control panel and/or the building breaker will trip. This condition can be remedied only by reducing the total amperage draw.

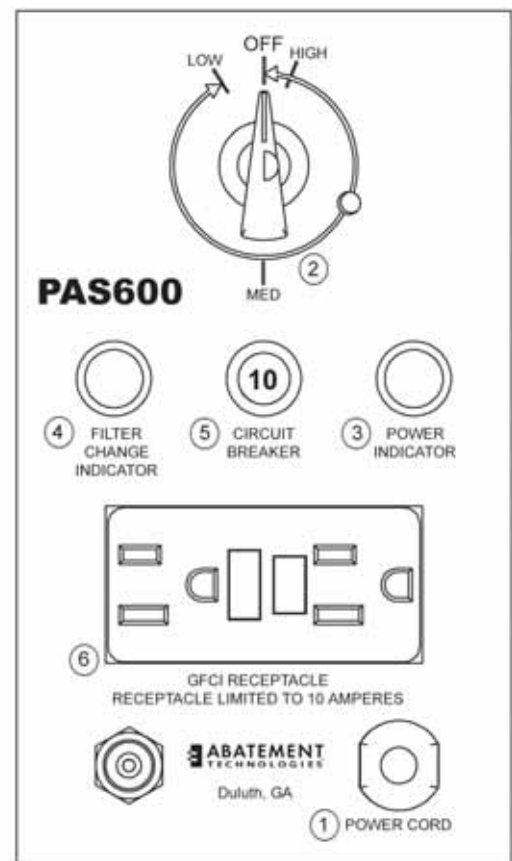



## **TO START UNIT**

1. Plug power cord into a 115 volt supply circuit.
2. Turn Speed Control switch clockwise past the click at the "HIGH" setting to turn power "ON".
3. Set Speed Control switch to desired setting.

## **FILTER CHANGE INDICATOR**

Light "ON" indicates one or more of the following:

1. Filters are loaded. Refer to filter change procedures.
2. Blocked air intake. Refer to Troubleshooting Guide.

## **FILTER REPLACEMENT**

Note: Personnel responsible for changing filters are urged to wear NIOSH approved respirators and other personal protective equipment in accordance with employer, state, and federal regulations.

The PAS600 has a built-in warning system which visibly (filter change indicator light "ON") signals when there is too high of a pressure drop across the filters (filter(s) are loaded) or air intake is blocked.

Note: The filters are not reusable, therefore, do not attempt to clean and reuse them.

System air flow reduction is generally the result of filter loading or blockage of the unit's inlet or flex duct connected to the inlet. For example, loose debris may be drawn into the inlet or flex duct and restrict air flow.

The size and concentration of airborne contaminants, temperature and humidity conditions, and duration of use determine how often filters need replacement. If the Filter Change Indicator on the control panel illuminates (this can only occur when the unit is operating on "HIGH" speed), this indicates: (1) the first and/or second stage filter(s) are loaded, (2) the inlet is obstructed, and/or (3) the flex duct, if any, is too long or has too many bends. Due to the design of the PAS600, the Filter Change Indicator system does not measure pressure drop across the HEPA filter. The HEPA filter should be changed every 1 1/2 - 2 years.

The method of determining when to replace the activated carbon filter is somewhat subjective. As the odor, vapor, and/or gas filtration capacity decreases, the user will begin to sense a slight odor or taste of the contaminant, indicating that the filter should be replaced.

## **FILTER CHANGE PROCEDURE**

Note: The first and second stage filters are housed inside the filter access door which is mounted to the PAS600 inlet side. To access the filters, push "down" on the 2 spring buttons located on the top panel and pull the door open. To properly close the access door, push it back inside the PAS600 until the 2 spring buttons pop through the door flange.

### **To Change the First Stage Filter:**

- With the unit operating, open the filter access door, remove the first stage filter, replace it with a new one and close the door.

- If the filter change indicator remains "ON" after changing the first stage filter, the second stage filter should be replaced.

**To Change the Second Stage Filter:**

- With the unit operating, open the filter access door, remove the second stage filter and replace it with a new one.

**To Change the HEPA Filter:**

1. Turn the unit "OFF" and disconnect the power cord from the electrical outlet.
2. Open the filter access door and remove the first and second stage filters.
3. Using a 7/16" socket wrench, remove the 2 nuts which secure the HEPA filter retaining bracket in place. Remove the HEPA filter and dispose of it.
4. Inspect the gasket on the HEPA filter; make sure there are **NO** cracks, gaps or defects. Cracks, gaps and defects could permit leakage of contaminated air through the unit. Install a new HEPA filter and make sure **THE GASKET END OF THE HEPA IS PLACED INTO THE UNIT FIRST**. When installing the HEPA filter, the retaining bracket and retention nuts must be fastened securely to prevent air leaks but not overtightened.
5. Install the first and second stage filters and close the filter access door. Whenever the HEPA filter is replaced, the first and second stage filters should also be replaced.

**Warning: Use only Abatement Technologies prefilters, HEPA filters, and replacement parts. Substitute parts void the warranty, jeopardize worker and environmental safety, and adversely affect engineered performance levels.**

**Caution: This unit is automatically operated device and may restart without warning. To reduce risk of injury, always disconnect from power supply before servicing unit.**



## PAS600 SPECIFICATIONS

FEATURE	PAS600
Net weight w/filters:	46 lbs.
Shipping weight:	55 lbs.
Dimensions (LxWxH):	28"L x 16 1/4"W x 17 1/2"H
Operational Sound Level:	62 - 67 dBA, reading taken at 5 feet
Power supply requirements:	115 volts, 15 amps
Maximum operating amps:	2.0 amps
Normal operating amps:	1.9 amps
Motorized impeller:	600 cfm @ 0 inches of water column (WC) static pressure, 2700 RPM, 150 watts, thermal overload protection with auto-reset, 60 HZ, single phase.
Operating flow rate: (with clean filters)	600 CFM (high speed) 50 CFM (low speed)
Cabinet material:	20 gauge stainless steel
Cabinet construction:	Assembled with rivets
Carrying handle:	Yes - top of cabinet
Stackable:	4 plastic guides on the top panel and 4 rubber feet on bottom panel.
High pressure warning system-locked intake and/or filter overload:	Amber light
First stage prefilter:	1" coarse particulate prefilter
Second stage prefilter:	2" carbon-impregnated particulate filter
Final filter:	HEPA filter which is 99.97% efficient against 0.3 micron particles.

**Note: Specifications subject to change without notice.**

## TROUBLE SHOOTING GUIDE

PROBLEM	POSSIBLE CAUSE	SOLUTION
No response when the power is turned on.	Defective power cord	Check all connections and condition of all cords. Do not operate with damaged power cord(s).
	Tripped circuit breaker	Unplug any additional equipment connected to the GFCI receptacle. Reset circuit breaker for building.  Reset breaker on control panel
	Tripped GFCI	Reset GFCI on control panel and/or at power source.
	Thermal overload on the motor has tripped	Turn unit "OFF", wait 30 minutes and restart unit.
Amber light "ON".	Loaded filters.	See "Filter Change Procedure" section.
	Excessive restrictions.	Reduce bends and/or length of flex duct or other restrictions.

**Note: If the unit does not start or malfunctions after carefully following the Troubleshooting Guide, call Abatement Technologies at 800-634-9091 for assistance.**

## COMPONENT REPLACEMENT

Occasionally a defective component will cause the unit to operate improperly or not at all. Any electrical device can fail. Refer to the WIRING SCHEMATIC OR WIRING DIAGRAM to diagnose the failure of any component. Diagnostics should only be performed by a qualified technician.

## REMOVAL OF THE CONTROL PANEL FOR SERVICING

**Caution: Always turn "OFF" the unit and disconnect it from the power source before removing the control panel, or replacing the HEPA filter.**

The control panel of the PAS600 machine is modular allowing for easy access and servicing. All control panel components are wired with 1/4" quick connect terminals.

## LIMITED WARRANTY

Abatement Technologies, Inc (ATI) warrants that goods sold to the original user shall be free from defects in material and workmanship for a period of 1 year, except such as are commercially acceptable. This warranty does not include useful filter life. **ATI does not warrant that the goods sold are merchantable or fit for any particular purpose. ATI makes no warranties other than as stated in the first sentence of this paragraph. All other warranties, guaranties, or representations, express or implied, by operation of law or otherwise, are expressly disclaimed.** Goods found by ATI to be defective or not to conform to specification shall upon return be replaced or repaired by ATI without any additional charges, or, at ATI's option, ATI may refund the purchase price of such goods. ATI will pay return transportation charges on returned goods not exceeding the transportation charges applicable to shipment from original destination unless the returned goods are free from defect and conform to specifications. Returned goods which are found by ATI to be free from defect and to conform to specifications shall be held for Purchaser's shipping instructions, which instructions Purchaser shall furnish promptly upon request. **ATI's liability shall in no event extend beyond replacement, repair or refund of the purchase price and ATI shall not be liable under any circumstances for special, contingent or consequential damages, nor for loss, damages, or expenses directly or indirectly arising from the use of the goods, including without limitation, warehousing, labor, handling and service charges, die, equipment, or machine breakage, nor for costs, lost profits or loss of good will. The use of substitute, non-ATI parts and/or filters, in any ATI product, voids all warranties and performance claims. The remedies set forth herein are exclusive.**

For warranty information and assistance contact Abatement Technologies' Customer Service Department at 800-634-9091 (U.S.) or 905-871-4720 (Canada.)

Abatement Technologies' HEPA-AIRE® and HEPA-CARE® high-efficiency air filtration units are originally equipped with true HEPA (High Efficiency Particulate Air) filters designed to maximize the performance of the equipment, and to meet the following industry standards:

**Institute of Environment Sciences and Technology**

IEST-RP-CC001.3 (Type A HEPA and ULPA Filters)

IEST-RP-CC021.1 (Testing HEPA and ULPA Filter Media)

**Underwriters Laboratories**

UL900, Class II (Flammability Specifications)

**100% Efficiency Tested**

Abatement Technologies HEPA filters are individually tested and certified to ensure that the completed filter provides an overall minimum efficiency of 99.97% when challenged by a thermally generated test aerosol 0.3-microns in size, in accordance with IEST-RP-CC001.3.

# PAS600 Wiring Schematic

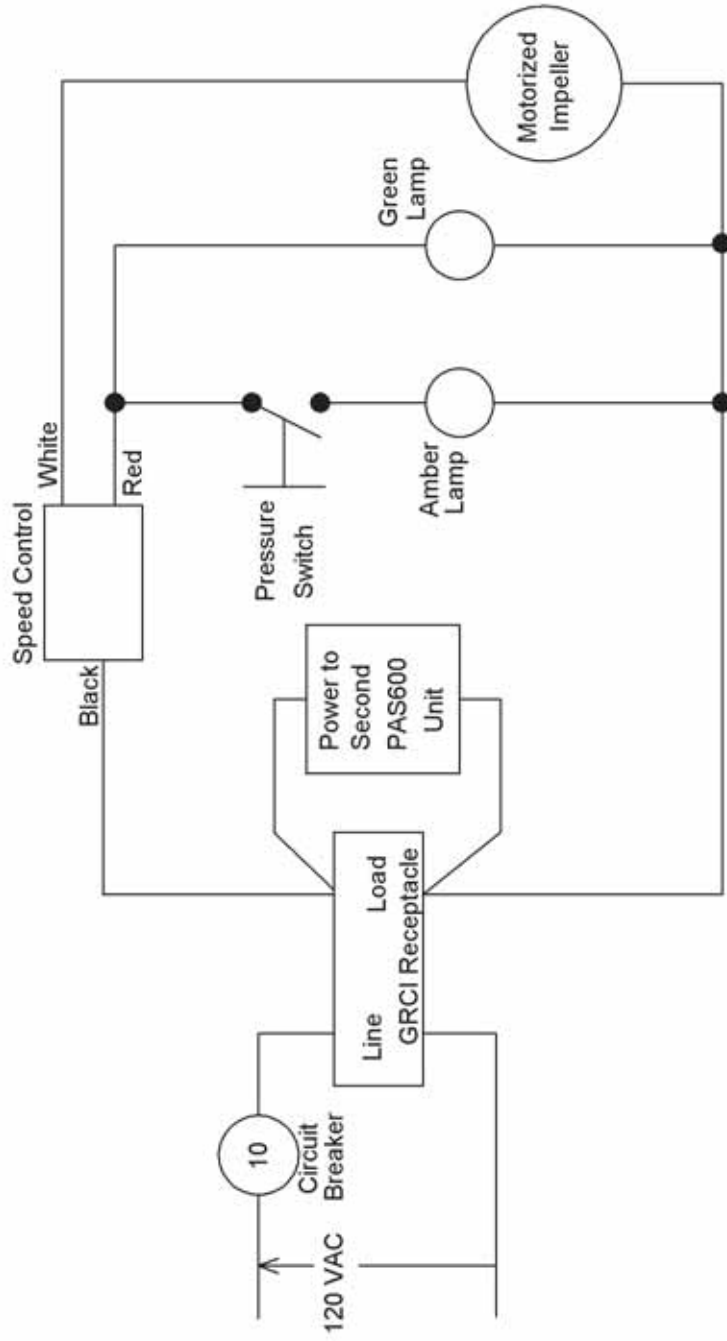

# PAS600 Wiring Diagram

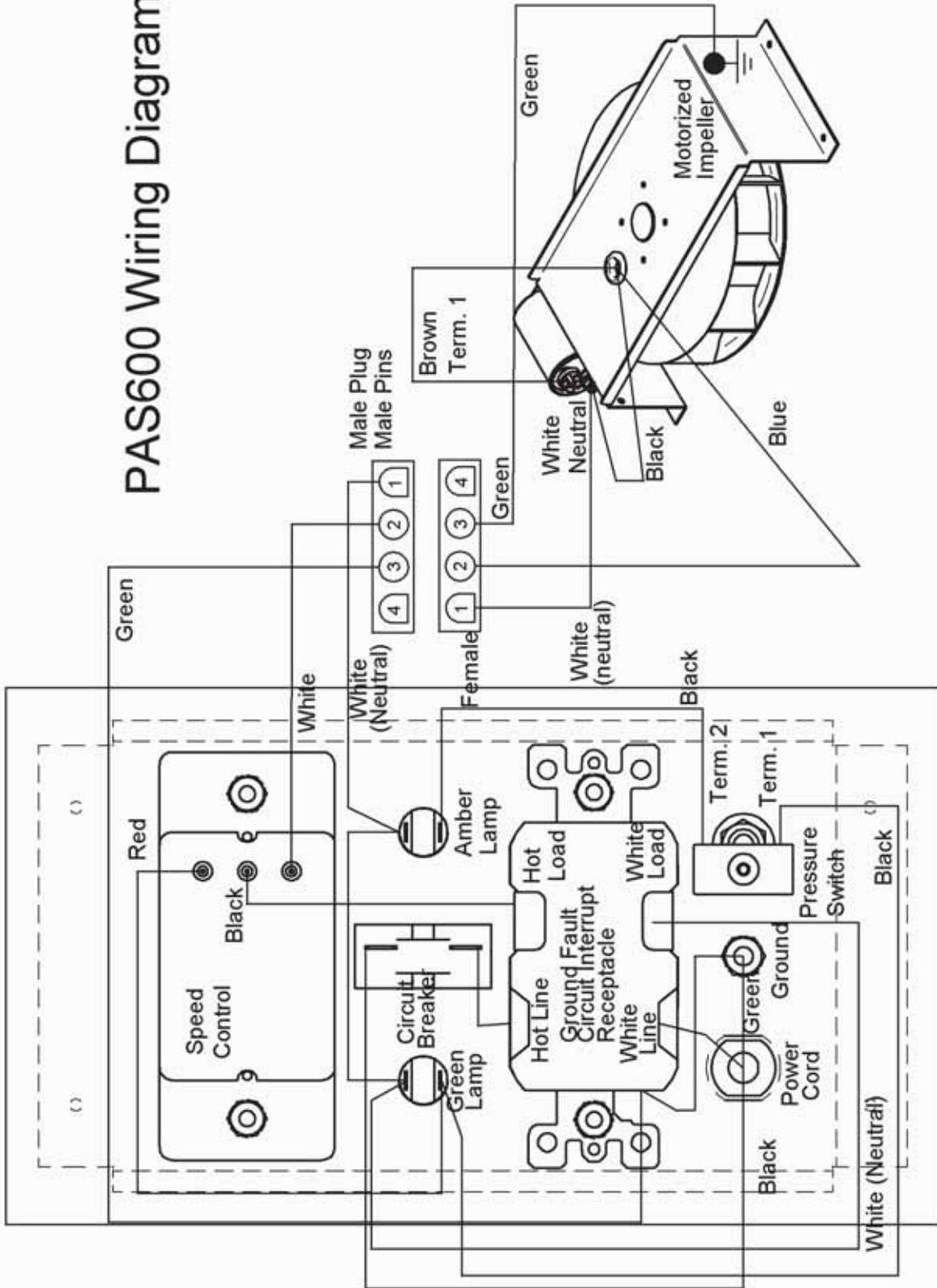

## ACTIVATED CARBON ADSORBENCY OF SELECTED SUBSTANCES AND ODORS

E= EXCELLENT

G= GOOD

P= POOR

NR= NOT RECOMMENDED

NOTE: SEE REVERSE SIDE FOR A MORE DETAILED EXPLANATION OF RATINGS.

Acetaldehyde	P	Chloropierin	E	Ethylene dichloride	E
Acetic Acid	E	Cigarette smoke odor	E	Ethylene oxide *	G
Acetic Anhydride	E	Cleaning compounds	E	Eucalyptole	E
Acetone	G	Coal smoke odor	G	Exhaust fumes	G
Acetylene	NR	Combustion odors	G	Fertilizer	E
Acrolein	G	Cooking odors	E	Film processing odors	G
Acrylic Acid	E	Corrosive gases	G	Fish odors	E
Acrylonitrile	E	Creosote	E	Floral scents	E
Adhesives	E	Cresol	E	Fluorotrichloromethane	G
Alines	P	Crotonaldehyde	E	Formaldehyde *	P
Ammonia *	P	Cyclohexane	E	Gasoline	E
Amyl acetate	E	Cyclohexanol	E	Glutaraldehyde *	P
Amyl alcohol	E	Cyclohexanone	E	Heptane	E
Amyl ether	E	Cyclohexene	E	Heptylene	E
Anesthetics	G	Decane	E	Hexane	G
Aniline	E	Decaying Substances	E	Hexylene	G
Antiseptics	E	Detergents	E	Hexyne	G
Asphalt fumes	E	Dibromoethane	E	Hospital odors	E
Benzene	E	Dichlorobenzene	E	Household smells	E
Bleaching solutions	G	Dichlorodifluoromethane	E	Hydrogen	NR
Body odors	E	Dichloroethane	E	Hydrogen bromide	G
Borane	G	Dichloroethylene	E	Hydrogen chloride	P
Bromine	E	Dichloroethyl ether	E	Hydrogen cyanide	G
Burned flesh	E	Dichloromonofluoromethane	G	Hydrogen fluoride	P
Butadiene	G	Dichloronitroethane	E	Hydrogen iodide	G
Butane	P	Dichloropropane	E	Hydrogen selenide	P
Butanone	E	Dichlorotetrafluoroethane	E	Hydrogen sulfide	G
Butyl acetate	E	Diesel fumes	E	Indole	E
Butyl alcohol	E	Diethylamine	G	Inorganic chemicals	G
Butyl cellosolve	E	Diethyl ketone	E	Iodine	E
Butyl chloride	E	Dimethylaniline	E	Idoform	E
Butyl ether	E	Dimethylsulfate	E	Isophorone	E
Butylene	P	Dioxane	E	Isoprene	G
Butyne	P	Dipropyl ketone	E	Isopropyl acetate	E
Butyraldehyde	G	Disinfectants	E	Isopropyl alcohol	E
Butyric acid	E	Embalming odors	E	Isopropyl ether	E
Camphor	E	Ethane	NR	Kerosene	E
Caprylic acid	E	Ether	G	Lactic acid	E
Carbolic acid	E	Ethyl acetate	E	Lubricating Oils & grease	E
Carbon disulfide	E	Ethyl acrylate	E	Medicinal odors	E
Carbon dioxide	NR	Ethyl alcohol	E	Menthol	E
Carbon monoxide	NR	Ethyl amine	G	Mercaptans	E
Carbon tetrachloride	E	Ethyl benzene	E	Mesityl oxide	E
Cellosolve	E	Ethyl bromide	E	Methane	NR
Cellosolve acetate	E	Ethyl chloride	G	Methyl acetate	G
Charred materials	E	Ethyl ether	G	Methyl acrylate	E
Chlorine *	G	Ethyl formate	G	Methyl alcohol	G
Chlorobenzene	E	Ethyl mercaptan	G	Methyl bromide	G
Chlorobuadiene	E	Ethyl silicate	E	Methyl butyl ketone	E
Chloroform	E	Ethylene	NR	Methyl cellosolve	E
Chloronitropropane	E	Ethylene chlorohydrin	E	Methyl cellosolve acetate	E

\* Special adsorbent filter packs are available for these items. Call our Customer Service Department for additional information.



Methylchloride	G	Perfumes, cosmetics	E	Smoke	E
Methyl chloroform	E	Pet odors	E	Solvents	G
Methyl ether	G	Phenol	E	Spoiled food stuffs	E
Methyl ethyl ketone	E	Phosgene	G	Stoddard solvent	E
Methyl Formate	G	Pitch	E	Styrene monomer	E
Methyl ether	G	Plastics	E	Sulfur dioxide	P
Methyl mercaptan	E	Poultry odors	E	Sulfur trioxide	G
Methylcyclohexane	E	Propane	P	Sulfuric acid	E
Methylcyclohexanol	E	Propionaldehyde	G	Tar	E
Methylcyclohexanone	E	Propionic acid	E	Tarnishing gases	G
Methylene chloride	E	Propyl acetate	E	Tetrachloroethylene	E
Mildew	G	Propyl alcohol	E	Tobacco smoke odor	E
Mold	G	Propyl chloride	E	Toluene	E
Monochlorobenzene	E	Propyl ether	E	Toluidine	E
Monofluorotrichloromethane	E	Propyl mercaptan	E	Trichloroethylene	E
Ozone	E	Propylene	P	Trichloroethane	E
Packing house odors	E	Propyne	P	Turpentine	E
Paint & redecorating odors	E	Putrescine	E	Urea	E
Palmitic acid	E	Pyridine	E	Uric acid	E
Paradichlorobenzene	E	Resins	E	Valeric acid	E
Pentane	G	Rubber	E	Valeraldehyde	E
Pentanone	E	Sewer odors	E	Vinegar	E
Pentylene	G	Skatole	E	Vinyl chloride	G
Pentyne	G	Smog	E	Wood alcohol	G
Perchloroethylene	E	Soaps	E	Xylene	E

Some of the contaminants listed in the table use specific chemical compounds, some represent classes of components, and others are mixtures of variable composition. Activated charcoal's capacity for odors varies somewhat with the concentration of air, humidity, temperature, and with the actual velocity through the filters. The numbers given represent typical or average conditions and might vary in specific instances. The values in the table have been assembled from many sources including laboratory tests and field experience. In cases where numerical values were not available, the probable capacity based on general experience has been listed. This table should be used as a general guide only. The capacity index has the following meaning:

- E - Excellent adsorption of this substance. The activated charcoal will adsorb 20% to 50% of its weight of this substance.
- G - Good adsorption. Capacity is 10% - 20%.
- P - Generally poor adsorption. Under certain conditions, satisfactory performance is possible, but adsorption is very low (less than 10%).
- NR- Very poor adsorption. Use of activated carbon filters is not recommended for these substances.

**WARNING:** Any atmospheres containing combustible gases, oxygen-deficient gases, gases of an unknown origin and/or concentration, or gases exceeding permissible exposure level or threshold limit value must be properly identified by a certified professional and requires appropriate protection measures as indicated by the National Institute of Occupational Safety and Health (NIOSH) and the Mine Safety and Health Administration (MSHA). Use of carbon filters DOES NOT constitute a safe working environment.

- Special adsorbent filter packs are available for these items. Call our Customer Service Department for additional information.