

Owner's Manual — Phoenix 200 MAX

Installation, Operation & Service Instructions

Read and Save These Instructions

The Phoenix 200 MAX is one of the most effective and versatile drying devices available. The 200 MAX removes more water and has more grain depression than other refrigerant dehumidifiers, even though it only requires 7.4 amps of electricity.

The term LGR (Low Grain Refrigerant) was created to describe the unique drying capabilities of the Phoenix 200 dehumidifier. These units were known for delivering substantially drier air, as well as for drying areas to much lower humidity levels than conventional dehumidifiers. The Phoenix 200 MAX, an improved version of the original Phoenix 200, is the culmination of over a decade of LGR manufacturing and design expertise.

The Phoenix 200 MAX LGR, High Capacity Dehumidifier

- **Improved water removal**
+16 gals/day (133 pints) AHAM (80°F, 60%)
30 gals/day maximum
- **Improved grain depression**
The driest air from an LGR
- **Multiple air filter options**
Standard 65% MERV-11, 57% MERV-8, or
95% MERV-14
- **Multiple ducting options**
12" intake, 10" lay-flat exhaust
- **Less than 7.5 amps**
Removes the most pints of water per kilowatt
- **Stainless steel cabinet**
- **Internal pump with 30 feet of hose**
- **Five-year warranty on the sealed refrigeration system.**



Phoenix 200 MAX
PN 4024920

Table of Contents

Introduction	1
1. Specifications	2
2. Operation	2
2.1 Transporting the Phoenix 200 MAX	2
2.2 Location	2
2.3 Electrical Requirements	3
2.4 Condensate Removal.....	3
2.5 Ducting.....	3
2.6 Power Switch	3
2.7 Pump Purge Switch.....	3
2.8 Hour Meter	3
2.9 Defrost Control Adjustment	3
2.10 Low Pressure Control.....	4
3. Maintenance	4
3.1 Air Filter.....	4
3.2 Storage	4
4. Service	4
4.1 Warranty	4
4.2 Technical Description.....	4
4.3 Troubleshooting.....	5
4.4 Refrigerant Charging	5
4.5 Blower Replacement.....	5
4.6 Compressor/Capacitor Replacement	6
4.6A Checking Compressor Motor Circuits	6
4.6B Replacing a Burned Out Compressor	6
4.6C Replacing a Compressor- Non-Burn Out.....	7
4.7 Defrost Thermostat & Timer	7
4.8 Condensate Pump	7
4.9 Gravity Drain Option.....	7
4.10 Relay.....	7
5. Wiring Diagram	8
6. Service Parts List	9
7. Warranty	11

Serial No. _____

Purchase Date ____/____/____

Dealer's Name _____

Read the operation and maintenance instructions carefully before using this unit. Proper adherence to these instructions is essential to obtain maximum benefit from your Phoenix 200 MAX dehumidifier.

1 Specifications

Part No.	4024920
Power	110-120 Vac, 7.4 amps; 851 watts
Water Removal	133 pints/day @ AHAM (80°F, 60%) 240 pints/day @ saturation 30 gal/day maximum @ saturation
Refrigerant Charge	1 lbs., 14 oz. R-22
Blower	265 CFM Internal Condensate Pump with 20 lift, 30' vinyl hose
Operating Range	33°F to 105°F
Filters	16" x 20" Standard 2" Pleated Media 30%* MERV-6 Optional 2" Pleated Media 30%* MERV-8 Optional 2" Pleated Media 65%* MERV-11 Optional 4" Mini-Pleat Media 95%* MERV-14
Duct Options	Intake – 12" Flex-Duct Supply – 10" Lay-Flat
Warranty	Five years; First year 100% of Parts and Labor Second-fifth year 100% of Parts of sealed refrigeration system.

Dimensions:

	Cabinet	w/Cart	Shipping
Width	20"	24-1/4"	27-1/2"
Height	40"	40"	45-1/2"
Depth	18-1/4"	21-3/8"	22"
Weight		131 lb	160 lb

2 Operation

2.1 Transporting the Phoenix

The Phoenix 200 MAX must always be upright when transported by vehicle. It may be tipped on to its handle and back for loading and moving by hand.

2.2 Location

Note the following precautions when locating the Phoenix 200 MAX:

- It is designed to be used **INDOORS ONLY**.
- If used in a wet area, plug it into a **GROUND FAULT INTERRUPTER**.
- **DO NOT** use the Phoenix 200 MAX as a bench or table.
- It must always be used in the upright position.

- The air inlet on top & the side outlet must be at least 1 foot from walls and other obstructions to air flow.
- If the humid area is very large, dehumidification can be improved by adding an outlet duct to circulate air to stagnant areas (see Sec. 2.5).

2.3 Electrical Requirements

The Phoenix 200 MAX plugs into a common grounded outlet on a 15 Amp circuit. It draws 7.4 Amps at 80°F, 60% RH. Amp draw increases with increasing temperature and/or humidity; e.g. 10.2 amps at 90°F, 85% RH. If used in a wet area, a ground fault interrupter (GFI) is required.

If an extension cord is required, it must have a minimum of 14 gauge conductors if 25 feet long or less and 12 gauge conductors if greater than 25 feet long.

2.4 Condensate Removal

The Phoenix 200 MAX is equipped with an internal condensate pump to remove the water that is condensed during dehumidification. This allows the condensate to be pumped 30' with the attached hose. If the condensate must be pumped more than 20 feet above the unit, a second pump must be added to relay the condensate. If the pump fails and the unit must be used before it can be replaced, the condensate can be drained by gravity (see Sec. 4.9).

2.5 Ducting

A detachable rectangular exhaust collar is supplied that will allow 10" round lay-flat duct to be attached to the Phoenix 200 MAX outlet. Lay-flat plastic ducting is available from Therma-Stor.

To attach ducting to a collar, put the plastic duct end through the collar center and roll the duct end outward so that it overlaps the outside of the collar. The duct and collar may then be quickly attached to the Phoenix 200 MAX by snapping the collar over the four screws at the blower outlet.

2.6 Power Switch

The power switch (right of hour meter) lights up when the unit is turned on. The unit will continue to run in all conditions until the switch is turned off; there is no dehumidistat. If the unit is going to run for more than 2 hours in an area below 50°F, the defrost timer should be adjusted to improve performance (see Sec. 2.9).

2.7 Pump Purge Switch

This switch (left of hour meter) minimizes the water left in the condensate pump reservoir for moving or storage. Pressing and holding the pump purge switch will cause the condensate pump to run. Hold the switch in until the flow from the condensate hose stops.

2.8 Hour Meter

The digital hour meter measures the cumulative time that the unit is turned on to tenths of an hour. It stores its total when the unit is unplugged; the previous total will be displayed when the unit is next turned on. It resets to zero after 99,999.9 hours of operation.

2.9 Defrost Control Adjustment

When the Phoenix 200 MAX is used in a cool area, or the dewpoint is below 50°, frost will form on the cooling coil as it dehumidifies. When enough frost forms, the defrost thermostat will initiate the timed defrost cycle. The cycle periodically turns off the compressor while allowing the blower to run. The frost is melted by the air that the blower draws through the cooling coil.

DRYING TIP: Air's ability to absorb moisture from wet surroundings and the Phoenix 200 MAX's ability to remove moisture from that air is greatly improved at higher temperatures. We recommend that the area to be dried be heated to over 70 °F if possible. Less drying time will be required and efficiency will improve.

The defrost cycle is automatic and designed for optimum performance above 50°F. If the unit is used in an area that is below 50°F for more than 2 hours, adjustment of the defrost timer is recommended. To adjust the defrost timer:

1. Unplug the unit.
2. Remove the top panel and the front cover (6 screws).
3. The timer is fastened to the base at the front of the unit. Every fourth peg around the dial is pushed out from the dial center except one section with 5 pegs out in a row. See figure 1. Each fourth "out" peg represents 15 minutes of compressor "off" time during every hour that the unit is in the defrost cycle.
4. To improve performance below 50°F, the compressor "off" time must be increased to 30 minutes per hour to allow the frost to completely melt. To do this, push the pegs out from the dial center so that the pegs alternate with 2 toward the center, then 2 out from the center, all the way around the dial except for the section now with 6 pegs out in a row (see Fig. 1).
5. Replace the cover and top panel.

Change the timer pegs back to the original pattern for use above 50°F.

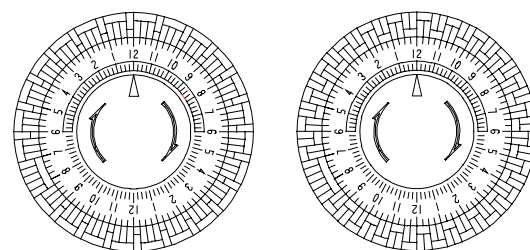

Figure 1: Defrost timer adjustment

2.10 Low Pressure Control

If the low side refrigerant pressure drops to 15 PSIG, the low pressure control opens and shuts off the compressor and blower. It is an automatically reset control. Its primary function is to prevent damage to the compressor if a leak develops in the refrigeration system. It may also open if the unit is A) used in a cool area (below 50°F) and the defrost timer is not adjusted (see Sec. 2.9) or B) stored where it is below 40°F and then started. Under these conditions, the unit will restart within several minutes; it may cycle several times until the unit warms up.

3 Maintenance

3.1 Air Filter

The Phoenix 200 MAX is equipped with a pleated fabric air filter that must be checked regularly. The standard filter is a MERV-11 high efficiency filter. Operating the unit with a dirty filter will reduce the dehumidifier's capacity and efficiency and may cause the compressor to cycle off and on unnecessarily on the defrost control.

The filter can generally be vacuumed clean several times before needing replacement. Replacement filters can be ordered from the factory or purchased locally if available. DO NOT operate the unit without the filter or with a less effective filter as the heat exchange coils inside the unit could become clogged and require disassembly to clean.

3.2 Storage

There are two issues to consider when the Phoenix 200 MAX is stored between uses and both pertain to the water trapped in the unit: damage caused by freezing or biological growth. The effect of the trapped water can be greatly reduced if precautions are taken to remove as much as possible before storage.

1. Use the pump purge switch (see Sec. 2.7 & Fig. 4) to reduce the water level in the reservoir.
2. Stretch the hose flat to drain it completely. Walk under out of the hose to open end.

If the unit will not be exposed to freezing temperatures, an alternative to reduce biological growth is to flush the unit with a bio-fungicide that is approved for use with copper, aluminum and polyethylene. To flush:

1. Run the hose to a drain.
2. Plug in the unit but do not turn it on.
3. Remove the air filter. Slowly pour a quart of the chemical through the heat exchanger
4. Hold in the pump purge switch to reduce the water level in the reservoir.
5. Flush with water.

4 Service

⚠ CAUTION

CAUTION: Servicing the Phoenix 200 MAX with its high pressure refrigerant system and high voltage circuitry presents a health hazard which could result in death, serious bodily injury, and/or property damage. Only qualified service people should service this unit.

4.1 Warranty

A warranty certificate has been enclosed with this unit; read it before any repair is initiated. If a warranty repair is required, call the factory first at 1-800-533-7533 for warranty claim authorization and technical assistance.

4.2 Technical Description

The Phoenix 200 MAX uses a refrigeration system similar to an air conditioner's to remove heat and moisture from incoming air, and to add heat to the air that is discharged (see Fig. 2).

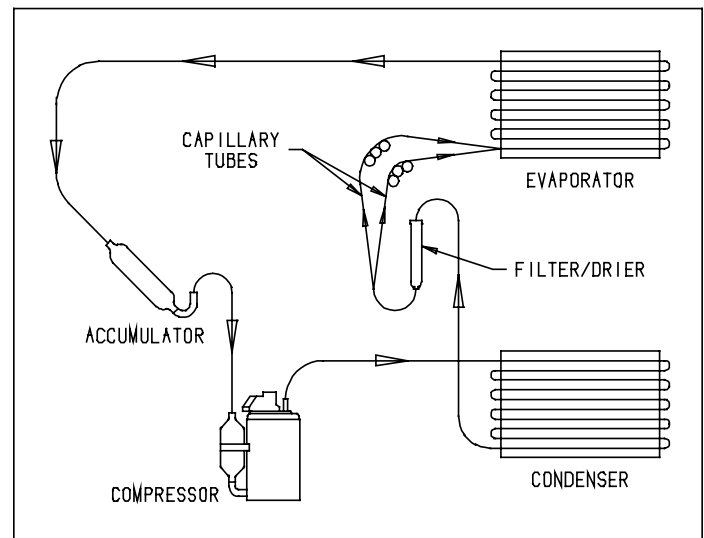

Figure 2: Refrigeration system of Phoenix

Hot, high pressure refrigerant gas is routed from the compressor to the condenser coil (see Figure 2). The refrigerant is cooled and condensed by giving up its heat to the air that is about to be discharged from the unit. The refrigerant liquid then passes through a filter/drier and capillary tubing which cause the refrigerant pressure and temperature to drop. It next enters the evaporator coil where it absorbs heat from the incoming air and evaporates.

The evaporator operates in a flooded condition, which means that all the evaporator tubes contain liquid refrigerant during normal operation. A flooded evaporator should maintain constant pressure and temperature across the entire coil, from inlet to outlet.

The mixture of gas and liquid refrigerant enter the accumulator after leaving the evaporator coil. The accumulator prevents any liquid refrigerant from reaching the compressor. The compressor evacuates the cool refrigerant gas from the accumulator and compresses it to a high pressure and temperature to repeat the process.

4.3 Troubleshooting

No dehumidification, neither blower nor compressor run and power switch does not light when ON.

1. Unit unplugged or no power to outlet.
2. Power switch defective (Sec. 2.6).
3. Loose connection in internal wiring (Fig. 3).

No dehumidification, neither blower nor compressor run with power switch ON & lit.

1. Low pressure control open (Sec. 2.10).
2. Power switch defective (Sec. 2.6).
3. Loose connection in internal wiring (Fig. 3).

Some dehumidification, blower runs continuously but compressor only runs sporadically.

1. Unit is in defrost cycle (Sec. 2.9 & 4.7).
2. Defrost thermostat defective or loose (Sec. 2.9 & 4.7).
3. Loose connection in compressor circuit (see Fig. 3).
4. Defective compressor overload (Sec. 4.6A).
5. Defective compressor (Sec. 4.6).
6. Defective relay (Sec. 4.10).

No dehumidification, blower runs but compressor does not.

1. Bad connection in compressor circuit (Fig. 3).
2. Pump safety switch closed
2. Defective compressor capacitor (Sec. 4.6A).
3. Defective compressor overload (Sec. 4.6A).
4. Defective compressor (Sec. 4.6).
5. Defective relay (Sec. 4.10).

Blower does not run. Compressor runs briefly but cycles on & off.

1. Loose connection in blower circuit (see Fig. 3).
2. Obstruction prevents impeller rotation.
3. Defective blower (Sec. 4.5).

Unit removes some water but not as much as expected.

1. Air temperature and/or humidity have dropped.
2. Humidity meter and/or thermometer used are out of calibration.
3. Unit has entered defrost cycle (Sec. 2.9 & 4.7).
4. Air filter dirty (Sec. 3.1).

5. Defrost timer incorrectly set for conditions (Sec. 2.9 & 4.7).
6. Defective defrost thermostat (Sec. 4.7)
7. Low refrigerant charge (Sec. 4.4).
8. Air leak such as loose front cover.
9. Defective compressor (Sec. 4.6).
10. Restrictive exhaust ducting (Sec. 2.5)

Unit runs but does not pump water.

1. Hose kinked or plugged.
2. Pump motor or float switch defective (Sec. 4.8).
3. Pump check valve plugged (Sec. 4.8).
4. Bad connection in pump circuit (Fig. 3).
5. Hose disconnected internally.

Unit pumps water automatically but not when purge switch is pushed.

1. Bad connection in purge switch circuit (Fig. 3).
2. Defective purge switch (Sec. 2.7).

Evaporator coil frosted continuously, low dehumidifying capacity.

1. Defrost thermostat loose or defective (Sec. 2.9 & 4.7).
2. Defrost timer incorrectly set or defective (Sec. 2.9 & 4.7).
2. Low refrigerant charge (Sec. 4.4).
3. Dirty air filter or air flow restricted. (Sec. 3.1).

Compressor runs with power switch OFF.

1. Defective relay (Sec. 4.10).
2. Defective power switch (Sec. 2.6)

4.4 Refrigerant Charging

If the refrigerant charge is lost due to service or a leak, a new charge must be accurately weighed in. If any of the old charge is left in the system, it must be removed before weighing in the new charge. Refer to the unit nameplate for the correct charge weight and refrigerant type.

4.5 Blower Replacement

The centrifugal blower has a PSC motor and internal thermal overload protection. If defective, the complete assembly must be replaced.

1. Unplug the power cord.
2. Remove the top panel and cabinet front (6 screws).
3. Disconnect the blower leads.
4. Remove the four screws holding the blower outlet flange to the cabinet end.

5. Rotate the blower outlet toward you as you remove it. Use care to avoid hooking wiring, tubing or electrical components.
6. Reassembling with the new blower in the above procedure reversed.

4.6 Compressor/Capacitor Replacement

This compressor is equipped with a two terminal external overload, run capacitor, but no start capacitor or relay (see Fig. 3).

CAUTION

CAUTION-ELECTRICAL SHOCK HAZARD: *Electrical power must be present to perform some tests; these tests should be performed by a qualified service person.*

4.6A Checking Compressor Motor Circuits

Perform the following tests if the blower runs but the compressor does not with the power switch ON.

1. Turn the power switch OFF and unplug the unit, remove top panel and the cabinet front (6 screws).
2. Plug in the unit and turn the power switch ON. Use a voltmeter to check for 110 to 120 volts between (a) the relay terminal that the black wire from the compressor connects to and (b) the capacitor terminal with the 2 white wires & blue wire connected. If voltage is present, go to step 3. If no voltage, the low pressure control or relay are open or there is a loose connection in the compressor circuit. Test each component for continuity; see the appropriate section if a defect is suspected.
3. Turn the power switch OFF and unplug the unit, then disconnect the red and yellow wires from compressor terminals R & S. Using an ohmmeter, check continuity between the points listed below.
4. Compressor terminals C and S: No continuity indicates an open start winding; the compressor must be replaced. Normal start winding resistance 3 to 7 ohms.
5. Compressor terminals C and R: No continuity indicates an open run winding; the compressor must be replaced. Normal run winding resistance is .5 to 2 ohms.
6. Compressor terminal C and overload terminal 1: No continuity indicates a defective overload lead.
7. Overload terminals 1 and 3: If there is no continuity, the overload may be tripped; wait 10 minutes and try again. If there is still no continuity, it is defective and must be replaced.
8. Compressor terminal C and compressor case: Continuity indicates a grounded motor; the compressor must be replaced.

9. Disconnect the wires from the capacitor. Set the ohmmeter to the Rx1 scale; the capacitor is shorted and must be replaced if continuity exists across its terminals. If there is no needle movement with the meter set on the Rx100000 scale, the capacitor is open and must be replaced.
10. Reconnect the wires to the compressor and capacitor; plug in and turn on the unit. If the compressor fails to start, replace the run capacitor.
11. If the unit still does not start, adding a hard-start kit will provide greater starting torque. If this does not work, the compressor has an internal mechanical defect and must be replaced.

4.6B Replacing a Burned Out Compressor

The refrigerant and oil mixture in a compressor is chemically very stable under normal operating conditions. However, when an electrical short occurs in the compressor motor, the resulting high temperature arc causes a portion of the refrigerant oil mixture to break down into carbonaceous sludge, a very corrosive acid, and water. These contaminants must be carefully removed otherwise even small residues will attack replacement compressor motors and cause failures.

The following procedure is effective only if the system is monitored after replacing the compressor to insure that the clean up was complete.

1. This procedure assumes that the previously listed compressor motor circuit tests revealed a shorted or open winding. If so, cautiously smell the refrigerant from the compressor service port for the acid odor of a burn out.

WARNING

WARNING: *The gas could be toxic and highly acidic. If no acid odor is present, skip down to the section on changing a non-burn out compressor.*

2. Remove and properly dispose of the system charge. DO NOT vent the refrigerant or allow it to contact your eyes or skin.
3. Remove the burned out compressor. Use rubber gloves if there is any possibility of coming in contact with the oil or sludge.
4. To facilitate subsequent steps, determine the type of burn out that occurred. If the discharge line shows no evidence of sludge and the suction line is also clean or perhaps has some light carbon deposits, the burn out occurred while the compressor was not rotating. Contaminants are therefore largely confined to the compressor housing. A single installation of liquid and suction line filter/driers will probably clean up the system.

If sludge is evident in the discharge line, it will likely be found in the suction line; this indicates the compressor burned out while running. Sludge and acid have been pumped throughout the system. Several changes of the liquid and suction filter/driers will probably be necessary to cleanse the system.

5. Correct the system fault that caused the burn out. Consult the factory for advice.
6. Install the replacement compressor with a new capacitor and an oversized liquid line filter.
In a running burn out, install an oversized suction line filter/drier between the accumulator and compressor. Thoroughly flush the accumulator with refrigerant to remove all trapped sludge and to prevent the oil hole from becoming plugged. A standing burn out does not require a suction line filter/drier.
7. Evacuate the system with a good vacuum pump and accurate vacuum gauge. Leave the pump on the system for at least an hour.
8. Operate the system for a short period of time, monitoring the suction pressure to determine that the suction filter is not becoming plugged. Replace the suction filter/drier if pressure drop occurs. If a severe running burn out has occurred, several filter/driers may have to be replaced to remove all of the acid and moisture.

NOTE: NEVER use the compressor to evacuate the system or any part of it.

4.6C Replacing a Compressor- Non-Burn Out

Remove the refrigerant from the system. Replace the compressor and liquid line filter/drier. Charge the system to 50 PSIG and check for leaks. Remove the charge and weigh in the refrigerant quantity listed on the nameplate. Operate the system to verify performance.

4.7 Defrost Thermostat and Timer

The defrost thermostat is attached to the refrigerant suction tube between the accumulator and compressor. If the low side refrigerant temperature drops due to excessive frost formation on the evaporator coil, the thermostat opens. The compressor is then cycled off and on by the defrost timer. The blower will continue to run, causing air to flow through the evaporator coil and melt the ice when the compressor is off. When the air temperature and/or humidity increase, the evaporator temperature will rise and the thermostat will close to end the defrost cycle.

To improve performance in low temperatures, see Sec. 2.9 for defrost timer adjustment.

4.8 Condensate Pump

Condensate is automatically pumped when the water level in the pump's reservoir rises to close the float switch or if the pump purge switch is held in.

To replace the condensate pump:

1. Remove the metal strap holding the pump by loosening the 2 screws holding it in place.
2. Disconnect the leads.
3. Installation is the reverse of above, but check that the plastic inlet and outlet hoses do not rub against copper refrigerant tubes.

4.9 Gravity Drain Option

If the condensate pump fails and cannot be replaced immediately, the Phoenix 200 MAX can be used by draining by gravity.

1. Unplug the unit and remove the front cover.
2. Push the plastic plug on the right side (see Fig. 4) out from inside the unit.
3. Locate the heavy vinyl hose that connects the drain pan to the condensate pump. Pull the end out of the pump.
4. Push that end of the vinyl hose through the hole in the right side.
5. Connect a garden hose and run it to a drain. Keep the hose as flat to the floor as possible to avoid air pockets that would hinder draining. Placing the unit on something above the floor will also improve draining.

4.10 Relay

The contacts of the single pole, single throw relay complete the power circuit to the compressor. The contacts are closed when power is provided to the relay coil via the control circuit. The control circuit includes the power switch, low pressure control, defrost thermostat and timer.

5 Wiring Diagram

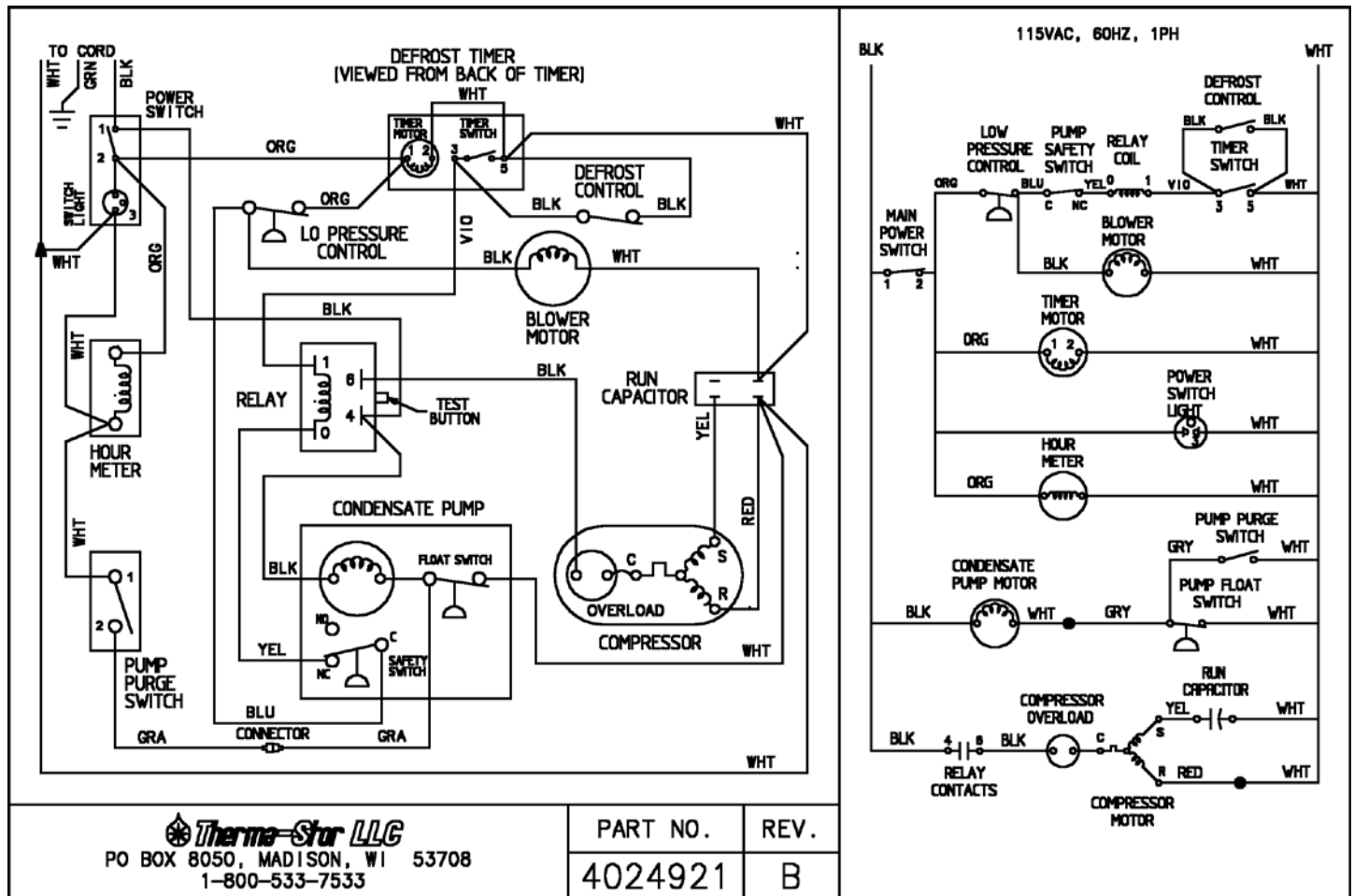

Figure 3: Electrical schematic of 200 MAX

6 Service Parts

Item	Part No.	Qty.	Description
1	4022254	1	Accumulator
	4021475	1	Air Filter, Pleated, 2" x 16" x 20" 65% Merv-11
2	4024682	1	Air Filter, Pleated, 2" x 16" x 20" 57% MERV-8 (optional)
	4022489	1	Air Filter, Pleated, 4" x 16" x 20" 95% Mini-Pleat MERV-14 (optional)
3	4022037	1	Blower
4	4021589	2	Capillary Tubes, .050" ID x .114" OD x 28" long
5	4023390	1	Compressor Kit, Carlyle (P/N EAA090111A)
	4022476	1	Overload, Carlyle Cprsr (included with compressor kit)
6	4024813	1	Cord
7	4023080	1	Coupling Insert, .38 Tube
8	4021470	1	Defrost Thermostat
	4021648	1	Defrost Thermostat Mounting Clip
9	4021395	1	Evaporator Coil
10	4020955	1	Filter/Drier
11	4024073	2	Foot
12	4026094	1	Handle Assembly
13	4021597	1	Hour Meter
14	4024918	1	Instruction Label
15	4022219	1	Low Pressure Control
16	4021796	1	Pump Purge Switch
17	4021822	1	Power Switch
18	4024903	1	Top

Item	Part No.	Qty.	Description
19	*****	1	Wheel/Axle Assembly
	4026304	2	Wheel, 12"
	4024904	1	Axle
	4025454	2	E-Ring
20	4024078	1	Wire Duct Collar (Exhaust)
21	4025043	1	Skid Panel
Items listed below are not shown			
22	4023649	1	Condensate Pump
23	4021396	1	Condenser Coil
24	4024910	1	Coupling Body, .25 Tube
25	4021823	1	Defrost Timer
26	4024916	1	Drain Hose (.25 ID x 33' long)
27	1096010	1	Front Panel Screw, 1/4-20 x 1
28	1205473	1	Front Panel Retaining Nut, 1/4 -20
31	1970010	1	Relay
32	4024912	1	Run Capacitor, 35 MFD, 370 Vac

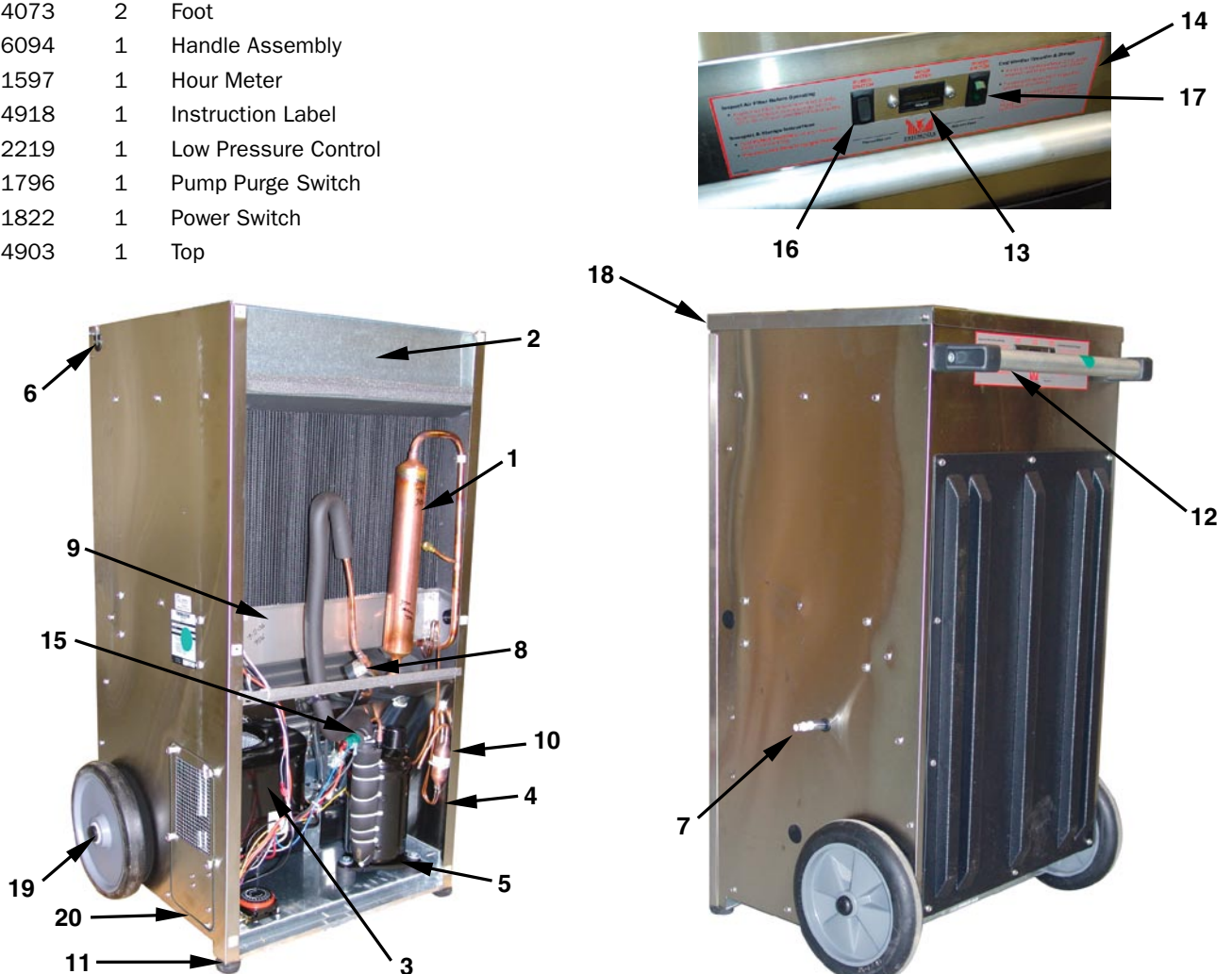

Figure 4

Specifications subject to change without notice.

This page intentionally left blank.

Phoenix 200 MAX Dehumidifier Limited Warranty

Warrantor:

Therma-Stor LLC
PO Box 8680
Madison, WI 53708
Telephone: 1-800-533-7533

Who Is Covered: This warranty extends only to the original end-user of the Phoenix 200 MAX dehumidifier, and may not be assigned or transferred.

First Year Warranty: Therma-Stor LLC warrants that, for one (1) year the Phoenix 200 MAX dehumidifier will operate free from any defects in materials and workmanship, or Therma-Stor LLC will, at its option, repair or replace the defective part(s), free of any charge.

Second Through Fifth Year Warranty: Therma-Stor LLC further warrants that for a period of five (5) years, the condenser, evaporator, and compressor of the Phoenix 200 MAX dehumidifier will operate free of any defects in material or workmanship, or Therma-Stor LLC, at its option, will repair or replace the defective part(s), provided that all labor and transportation charges for the part(s) shall be borne by the end-user.

End-User Responsibilities: Warranty service must be performed by a Servicer authorized by Therma-Stor LLC. If the end-user is unable to locate or obtain warranty service from an authorized Servicer, he should call Therma-Stor LLC at the above number and ask for the Therma-Stor Service Department., which will then arrange for covered warranty service. Warranty service will be performed during normal working hours.

The end-user must present proof of purchase (lease) upon request, by use of the warranty card or other reasonable and reliable means. The end-user is responsible for normal care. This warranty does not cover any defect, malfunction, etc. resulting from misuse, abuse, lack of normal care, corrosion, freezing, tampering, modification, unauthorized or improper repair or installation, accident, acts of nature or any other cause beyond Therma-Stor LLC' reasonable control.

Limitations and Exclusions: If any Phoenix 200 MAX Dehumidifier part is repaired or replaced, the new part shall be warranted for only the remainder of the original warranty period applicable thereto (but all warranty periods will be extended by the period of time, if any, that the Phoenix 200 MAX Dehumidifier is out of service while awaiting covered warranty service).

UPON THE EXPIRATION OF THE WRITTEN WARRANTY APPLICABLE TO THE PHOENIX 200 MAX DEHUMIDIFIER OR ANY PART THEREOF, ALL OTHER WARRANTIES IMPLIED BY LAW, INCLUDING MERCHANTABILITY AND FITNESS FOR A PARTICULAR PURPOSE, SHALL ALSO EXPIRE. ALL WARRANTIES MADE BY THERMA-STOR LLC ARE SET FORTH HEREIN, AND NO CLAIM MAY BE MADE AGAINST THERMA-STOR LLC BASED ON ANY ORAL WARRANTY. IN NO EVENT SHALL THERMA-STOR LLC, IN CONNECTION WITH THE SALE, INSTALLATION, USE, REPAIR OR REPLACEMENT OF ANY PHOENIX 200 MAX DEHUMIDIFIER OR PART THEREOF BE LIABLE UNDER ANY LEGAL THEORY FOR ANY SPECIAL, INDIRECT OR CONSEQUENTIAL DAMAGES INCLUDING WITHOUT LIMITATION WATER DAMAGE (THE END-USER SHOULD TAKE PRECAUTIONS AGAINST SAME), LOST PROFITS, DELAY, OR LOSS OF USE OR DAMAGE TO ANY REAL OR PERSONAL PROPERTY.

Some states do not allow limitations on how long an implied warranty lasts, and some do not allow the exclusion or limitation of incidental or consequential damages, so one or both of these limitation may not apply to you.

Legal Rights: This warranty gives you specific legal rights, and you may also have other rights which vary from state to state.

TS-206-1106

